

The GH-Method

Viscoelastic Glucose Theory (VGT #1): Applying the Concept of Viscoelasticity Theory to Conduct a “Glucose Analogy” Study and Illustrate Certain Viscoelastic Characteristics of Time-Dependent Glucose Using Continuous Glucose Monitoring (CGM) Sensor Device Collected Postprandial Plasma Glucose (PPG) Data of 4,056 Elastic Glucoses (<180 mg/dL) within a Period of 3.7 Years from 5/8/2018 to 1/10/2022 Based on GH-Method: Math-Physical Medicine (No. 578)

Gerald C. Hsu*

eclaireMD Foundation, USA

Note: Readers who want to get a quick overview can read the abstract, results, and graphs.

Abstract

The author has studied strength of materials and theory of elasticity from undergraduate courses at the University of Iowa. He also conducted research work to earn a master's degree in Biomechanics under Professor James Andrews. He remembers that he used both spring and dashpot models to simulate the behaviors of human bone, muscle, and tendon in order to investigate the human-weapon interactions. Later on, he went to MIT to pursue his PhD study under Professor Norman Jones who taught him theory of plasticity and dynamic plastic behaviors of various structure elements. Furthermore, he took some graduate courses at MIT in the field of fluid dynamics and thermodynamics. Since then, biomechanics has made advancements in a few application areas, especially tissues of human body which possess viscoelastic characteristics, such as bone, muscle, cartilage, tendon (connect bone to muscle), ligament (connect bone to bone), fascia and skin. For example, the night splint dorsiflexes forefoot on rear foot increasing plantar fascia tension to offer stress-relaxation of plantar fascia pain. This model of muscles and tendons connecting lower leg and foot is a kind of viscoelastic problem. However, when we deal with human internal organs, it is not easy to conduct live experiments to obtain some accurate measurements of material properties. Although blood itself is a viscous material which viscosity factor may sit between water and honey, syrup or gel. But the author's research subject is the “glucose”, the sugar amount inside of blood or carried by blood cells, not the blood itself. It is near impossible to measure

material geometry or engineering properties of glucose, for example, the viscosity of “glucose”. Therefore, the best he could do is to apply the concept of viscoelasticity and viscoplasticity to construct an analogy model in order to study the glucose behaviors which are time-dependent. The author's background covers mathematics, physics, and various engineering disciplines, not including biology and chemistry. As a result, he can only investigate the observed biomedical phenomena using his ready-learned math-physical tools. He has already investigated glucose behaviors using linear elasticity theory and nonlinear plasticity theory and written a few articles from his findings. Recently, Professor Norman Jones wrote an email to him. He said that “I have wondered if the use of viscoelastic/viscoplastic materials might be of some value to your studies. These phenomena embrace time-dependent behaviour and I know that you have emphasised the time-dependence of various behaviours in the body. Just a thought.” His suggestion has triggered the author's interest and desire to investigate glucose behaviors deeper and furthermore using viscosity theory. This particular article is his first attempt regarding validation of certain basic characteristics of viscoelastic glucose behaviors using his collected big data in real life during the past 3.7 years. One special note is that he ceased taking any diabetes medications since 12/08/2015. As a result, his research papers are “medication-free”. Once medication enters the body, it takes over the control of glucose outputs, i.e. symptoms. In most of his studies using CGM sensor collected glucose data after 12/08/2015, those raw data are totally

Received: 09 February 2022, Accepted: 03 March 2022, Available online: 10 March 2022

*Corresponding author: Gerald C. Hsu, eclaireMD Foundation, USA

“medication-free” or “free from chemical influences”. The only two influential forces or root-causes are nature health of his organs (liver and pancreatic beta cells) and his lifestyle management (specifically, diet and exercise), without any medication interventions or external biochemical influences. Elastic glucose vs. plastic glucose: The author has spent a considerable amount of research time during 2020 and 2021 to write 39 papers about his developed linear elastic glucose theory (LEGT). This LEGT can be expressed through the following linear elastic glucose equation: Predicted PPG = FPG * GH.f + (carbs&sugar grams) * GH.e + (post-meal walking k-steps * GH.w), where: GH.f-Modulus can estimate the starting PPG of a meal at 0-minute using FPG value during sleep; GH.e-Modulus can estimate the peak PPG level at 60-minutes after a meal using carbs&sugar grams; GH.w-Modulus can estimate the decreased PPG level at 180-minutes after a meal using post-meal walking k-steps. This linear elastic equation can be applied to his 4,056 meals with “elastic glucose” behaviors (99.5% of total). A synthesized PPG waveform, by combining all of the 4,056 elastic PPG curves together, has the following described biophysical behavior pattern. It starts from 123 mg/dL at 0-minute, where his PPG value increased due to the consumption of 13.5 grams of carbs/sugar for energy input (lower energy input or lower stress) and reaches a PPG peak level of 133 mg/dL at 60-minutes, before starting to decline due to walking exercise, which burns off the energy to finally return the glucose to its ending-PPG level of 122 mg/dL at 180-minutes. This end-glucose value returning to its initial-glucose position, after burning off energy influx, is called “elastic”. On the contrary, another scenario of the glucose behavior can be explained using his 23 meals with “plastic glucose” behaviors (0.5% of total). A synthesized PPG curve, by combining all of the 23 individual plastic PPG curves (>180 mg/dL, i.e. hyperglycemia) together, has the following different biophysical behavior pattern. It starts from 142 mg/dL at 0-minute, where his PPG value increases due to the consumption of 85.7 grams of carbs&sugar amount for energy input (higher energy input or higher stress) and then reaches to the first PPG peak level of 187 mg/dL at 60-minutes, but it continuously climbs but with a lower slope rate (43% of the earlier elastic phase) due to the excessive carbs&sugar consumption, until it reaches to its second peak PPG level of 207 mg/dL at 120-minutes. At this instant, the effect from his post-meal walking exercise finally kicks in to burn off the energy until it decreases to the end-glucose level of 191 mg/dL at 180-minutes. This end-glucose value of 191 mg/dL is still 49 mg/dL higher than its initial-glucose position of 142 mg/dL. This type of “permanent deformation” or “residual glucose” value of 49 mg/dL is called “plastic” or “elasto-plastic”. Based on other research papers (References 1 and 2), people without diabetes have PPG waveforms within a

range between 80 mg/dL (start and end) and 120 mg/dL (peak). For pre-diabetes patients, their PPG waveforms range between 100 mg/dL (start and end) and 180 mg/dL (peak). For severe diabetes patients who indeed possess “plastic glucose” phenomena, their PPG waveforms range between 180 mg/dL (starting), 370 mg/dL (peak at 1-hour), and 325 mg/dL (ending at 3-hours) or 270 mg/dL (if ending at 5-hours). Utilizing the author’s PPG data and curves to make a direct comparison against above-referenced glucose data and curves of normal people, pre-diabetes patients, and severe diabetes patients, they have remarkable resemblance. His elastic glucose data and curve are sitting between the normal case and the pre-diabetes case, while his plastic glucose data and curve are similar to severe diabetes case. In his plastic glucose study of NPGT, he has developed the following simplified plastic glucose equation: Predicted PPG = (carbs&sugar grams) * GH.e + (carbs&sugar grams) * GH.p + (post-meal walking k-steps * GH.w), where: GH.e-Modulus can estimate the first elastic peak PPG at 60-minutes after a meal using carbs&sugar grams; GH.p-Modulus can estimate the second elasto-plastic peak PPG at 120-minutes after a meal using the same value of carbs&sugar grams; GH.w-Modulus can estimate the decreased PPG at 180-minutes after a meal using post-meal walking k-steps. It should be noted that his plastic slope, GH.p-Modulus value of 0.254, is less than half or at the 43% level of his elastic slope, GH.e-Modulus value of 0.586. To offer a simple explanation to readers who do not have a physics or engineering background, the author includes a brief excerpt from Wikipedia regarding the description of basic concept of viscoelasticity theory and viscoplasticity theory from the disciplines of engineering and physics in the method section. The analogy between physics and medicine are two-fold. First, the force or stress (y-axis) in physics and engineering corresponds to the influential force or load on our body for pushing PPG upward or dragging PPG downward in medicine due to the combined effect of carbohydrates and sugar intake amount and post-meal walking exercise. This stress component has no difference between elastic and plastic. Second, the deformation or strain (x-axis) in physics and engineering corresponds to the actual PPG level in medicine. This strain component has difference between elastic glucose and plastic glucose. However, the medical field is still quite different from the engineering field, where the engineering materials such as steel, copper, concrete, and aluminum are inorganic material in most cases. These material properties do not change significantly over their expected lifespans. However, in medicine, the body with its organs and cells are organic material and go through many distinct stages over their natural lifespans, such as birth, splitting, growth, mutation, development, repair, sickness, and death. Therefore, the biomedical properties are “moving targets” which vary with the individual

person, severity of diabetes, and selected different time-windows. In another word, they are both time-dependent and specimen-dependent. Because of these fundamental characteristics, calculations of cross-section of subject and calculation of bending moment of resistance, or the shape-factors, etc. in solid mechanics are not applicable in this biomedical elasticity/plasticity or viscoelasticity study. The most important part, in the author's opinion, is that by applying the concept of plasticity theory or viscoelasticity theory on understanding the biomedical phenomena is extremely useful for exploring deep insights for predicting abnormal glucose behaviors in order to help the 100+ million diabetes patients or 1.3% of the world population of 7.9 billion who are currently suffering from hyperglycemia (i.e. high glucose level > 180 mg/dL). Energy theory: After declaring the analogy of elasticity and plasticity theories, the energy theory in physics must be brought into context. The human body and organs are composed of different organic cells that require energy infusion from glucose carried by red blood cells; and energy consumption from labor-work or exercise. When the residual energy resulted from plastic glucose scenario is stored inside of our bodies, it will cause different degrees of damage to many internal organs. According to physics, energies associated with the residual glucose waves are proportional to the square of the residual glucose amplitude. The residual energies from elevated glucoses are circulating inside the body via blood vessels which then impact all of the internal organs to cause different degrees of damage, i.e. diabetic complications. The author has applied Fast Fourier Transform (FFT) operations to convert the glucose wave from a time-domain into a frequency-domain. The y-axis amplitude values in the frequency-domain indicate the proportional energy levels associated with each different frequency component of glucose occurrence. Actually, both glucose value (i.e. strain amplitude in time-domain) and glucose fluctuation rate (i.e. the strain rate and strain frequency) are influencing the energy level (i.e. the Y-amplitude in frequency domain). Currently, many people live a sedentary lifestyle and lack sufficient exercise to burn off the energy influx which causes them to become overweight or obese. Overweight and obesity lead into chronic diseases, including diabetes. In addition, many types of processed food add unnecessary ingredients and harmful chemicals that are toxic to the bodies, which lead to the development of many other deadly diseases, such as cancers. For example, there are ~85% of worldwide diabetes patients who are overweight, and there are ~75% of patients of cardiac illnesses or surgeries have diabetes conditions. In engineering analysis, when the load is applied on the structure, it bends or twists, i.e. deforms; however, when the load is removed, it will either be restored (i.e. elastic) or remain in a permanent deformed shape (i.e. plastic) with plastic hinges. In a corresponding

biomedical analysis, after eating carbohydrates or sugar from food, our glucose level will increase; therefore, the sugar and carbohydrates function as the energy supply. After having labor work or exercise, the glucose level will decrease. As a result, the exercise burns off the energy, which is similar to load removal in the engineering case. In the biomedical case, both of the energy influx and energy consumption processes take some time which are not as simple and quick as the structural load removal in the engineering case. Therefore, the glucose behaviors, for both elastic glucose and plastic glucose, are "dynamic" in nature, i.e. time-dependent. This time-dependent nature leads into "visco-elastic or visco-plastic" situation. Time-dependent strain (glucose) and stress of (viscosity*glucose rate): The Hooke's law of linear elasticity is expressed as: Strain (ϵ : epsilon) = Stress (σ : sigma) / Young's modulus (E). For biomedical glucose application, his developed linear elastic glucose theory (LEGT) is expressed as: PPG (strain) = carbs/sugar (stress) * GH.p-Modulus (a positive number) + post-meal walking k-steps * GH.w-Modulus (a negative number), where GH.p-Modulus is reciprocal of Young's modulus E. However, in viscoelasticity theory, the stress is expressed as: Stress = viscosity factor (η : eta) * strain rate ($d\epsilon/dt$), where strain is expressed as Greek epsilon or ϵ . In this article, in order to construct an "ellipse-like" diagram in stress-strain space domain (e.g. "hysteresis loop") covering both positive side and negative side of the space, he has modified his definition of strain as follows: Strain = (PPG value at certain time instant) - (averaged PPG value). He also calculates his strain rate using the following formula: Strain rate = (PPG at next time instant - PPG at current time instant) / 15, where 15 indicates the 15 minutes time span of his CGM sensor glucose measurement. In order to study the impact on the viscoelastic hysteresis loop size (i.e. loop area) resulted from two different viscosity factors (η : eta), he has selected 1 for the lower viscosity case and 6 for the higher viscosity case. Please note that his average carbs/sugar intake amounts for elastic versus plastic cases are 13.5 grams versus 85.7 grams which is a ratio of 1.0 to 6.3. The objective of this particular article is to explore certain basic characteristics of viscoelasticity using the author's own collected elastic glucose (<180 mg/dL) data during a long period from 5/8/2018 to 1/10/2022. These explored some glucose characteristics using the viscoelastic or viscoplastic glucose theory (VGT) include stress relaxation, creep, hysteresis loop, material stiffness, damping effect based on time-dependent stress and strain which are different from his previous research findings using linear elastic glucose theory (LEGT) and nonlinear plastic glucose theory (NPGT). Actually, the hysteresis loops area of energy loss via heat has some connection with both energy theory and thermodynamics as well. In summary, the following three concluding remarks have described the findings of this particular

methodology paper. (1) From time-domain diagram of both strain curve ($d\epsilon/dt$, or PPG difference) and higher viscous stress curve (viscosity factor $\eta=6 * \text{PPG strain-rate}$), the data and curve between 45-minutes and 60-minutes explains the stress relaxation phenomenon (constant strain causes decreasing stress) while the data and curve between 15-minutes and 45-minutes explains the creep phenomenon (constant stress causes increasing strain). (2) The hysteresis loop area size of higher viscosity ($\eta = 6$) is much larger than the hysteresis loop area size of lower viscosity ($\eta = 1$) which mean a higher viscous material would have more energy loss into heat.

(3) Using the hysteresis loop map of higher viscosity ($\eta = 6$) as a sample, he can estimate that this loop area has a slope of around 10 degree which is also the rough estimated value of glucose material stiffness. Furthermore, he also calculates the ratio of minor axis length over the major axis length at a value of 1.67 as the damping value of glucose. The following combined diagram demonstrates certain viscoelastic characteristics of elastic PPG ($< 180 \text{ mg/dL}$) which includes stress relaxation and creep phenomena, hysteresis loops resulted from different viscosity parameters, and estimations of stiffness and damping.

Keywords: Viscoelasticity; Continuous glucose monitoring; Elastic glucose; Postprandial plasma glucose; Diabetes

Abbreviations: CGM: continuous glucose monitoring; HbA1C: hemoglobin A1C; MPM: math-physical medicine; FPG: fasting plasma glucose; PPG: postprandial plasma glucose

1. INTRODUCTION

The author has studied strength of materials and theory of elasticity from undergraduate courses at the University of Iowa. He also conducted research work to earn a master's degree in Biomechanics under Professor James Andrews. He remembers that he used both spring and dashpot models to simulate the behaviors of human bone, muscle, and tendon in order to investigate the human-weapon interactions. Later on, he went to MIT to pursue his PhD study under Professor Norman Jones who taught him theory of plasticity and dynamic plastic behaviors of various structure elements. Furthermore, he took some graduate courses at MIT in the field of fluid dynamics and thermodynamics.

Since then, biomechanics has made advancements in a few application areas, especially tissues of human body which possess viscoelastic characteristics, such as bone, muscle, cartilage, tendon (connect bone to muscle), ligament (connect bone to bone), fascia and skin. For example, the night splint dorsiflexes forefoot on rear foot increasing plantar fascia tension to offer stress-relaxation of plantar fascia pain. This model of muscles and tendons connecting lower-leg and foot is a kind of viscoelastic problem. However, when we deal with human internal organs, it is not easy to conduct live experiments to obtain some accurate measurements of material properties. Although blood itself is a viscous material which viscosity factor may sit between water and honey, syrup or gel. But the author's research subject is the "glucose", the sugar amount inside of blood or carried by blood cells, not the blood itself. It is near impossible to measure material geometry or engineering properties of glucose, for example, the viscosity of "glucose". Therefore, the best he could do is to apply the concept of viscoelasticity and viscoplasticity to construct an analogy model in order to study the glucose behaviors which are time-dependent.

The author's background covers mathematics, physics, and various engineering disciplines, not including biology and chemistry. As a result, he can only investigate the observed biomedical

phenomena using his ready-learned math-physical tools.

He has already investigated glucose behaviors using linear elasticity theory and nonlinear plasticity theory and written a few articles from his findings. Recently, Professor Norman Jones wrote an email to him. He said that "I have wondered if the use of viscoelastic/viscoplastic materials might be of some value to your studies. These phenomena embrace time-dependent behaviour and I know that you have emphasised the time-dependence of various behaviours in the body. Just a thought." His suggestion has triggered the author's interest and desire to investigate glucose behaviors deeper and furthermore using viscosity theory. This particular article is his first attempt regarding validation of certain basic characteristics of viscoelastic glucose behaviors using his collected big data in real life during the past 3.7 years.

One special note is that he ceased taking any diabetes medications since 12/08/2015. As a result, his research papers are "medication-free". Once medication enters the body, it takes over the control of glucose outputs, i.e. symptoms. In most of his studies using CGM sensor collected glucose data after 12/08/2015, those raw data are totally "medication-free" or "free from chemical influences". The only two influential forces or root-causes are nature health of his organs (liver and pancreatic beta cells) and his lifestyle management (specifically, diet and exercise), without any medication interventions or external biochemical influences.

1.1 Elastic glucose vs. plastic glucose

The author has spent a considerable amount of research time during 2020 and 2021 to write 39 papers about his developed linear elastic glucose theory (LEGT). This LEGT can be expressed through the following linear elastic glucose equation:

$$\text{Predicted PPG} = \text{FPG} * \text{GH.f} + (\text{carbs\&sugar grams}) * \text{GH.e} + (\text{post-meal walking k-steps} * \text{GH.w})$$

Where: GH.f-Modulus can estimate the starting PPG of a meal at 0-minute using FPG value during sleep;

GH.e-Modulus can estimate the peak PPG level at 60-minutes after a meal using carbs&sugar grams;

GH.w-Modulus can estimate the decreased PPG level at 180-minutes after a meal using post-meal walking k-steps.

This linear elastic equation can be applied to his 4,056 meals with “elastic glucose” behaviors (99.5% of total). A synthesized PPG waveform, by combining all of the 4,056 elastic PPG curves together, has the following described biophysical behavior pattern.

It starts from 123 mg/dL at 0-minute, where his PPG value increased due to the consumption of 13.5 grams of carbs/sugar for energy input (lower energy input or lower stress) and reaches a PPG peak level of 133 mg/dL at 60-minutes, before starting to decline due to walking exercise, which burns off the energy to finally return the glucose to its ending-PPG level of 122 mg/dL at 180-minutes. This end-glucose value returning to its initial-glucose position, after burning off energy influx, is called “elastic”.

On the contrary, another scenario of the glucose behavior can be explained using his 23 meals with “plastic glucose” behaviors (0.5% of total). A synthesized PPG curve, by combining all of the 23 individual plastic PPG curves (>180 mg/dL, i.e. hyperglycemia) together, has the following different biophysical behavior pattern.

It starts from 142 mg/dL at 0-minute, where his PPG value increases due to the consumption of 85.7 grams of carbs&sugar amount for energy input (higher energy input or higher stress) and then reaches to the first PPG peak level of 187 mg/dL at 60-minutes, but it continuously climbs but with a lower slope rate (43% of the earlier elastic phase) due to the excessive carbs&sugar consumption, until it reaches to its second peak PPG level of 207 mg/dL at 120-minutes. At this instant, the effect from his post-meal walking exercise finally kicks in to burn off the energy until it decreases to the end-glucose level of 191 mg/dL at 180-minutes. This end-glucose value of 191 mg/dL is still 49 mg/dL higher than its initial-glucose position of 142 mg/dL. This type of “permanent deformation” or “residual

glucose” value of 49 mg/dL is called “plastic” or “elasto-plastic”.

Based on other research papers (References 1 and 2), people without diabetes have PPG waveforms within a range between 80 mg/dL (start and end) and 120 mg/dL (peak). For pre-diabetes patients, their PPG waveforms range between 100 mg/dL (start and end) and 180 mg/dL (peak). For severe diabetes patients who indeed possess “plastic glucose” phenomena, their PPG waveforms range between 180 mg/dL (starting), 370 mg/dL (peak at 1-hour), and 325 mg/dL (ending at 3-hours) or 270 mg/dL (if ending at 5-hours).

Utilizing the author’s PPG data and curves to make a direct comparison against above-referenced glucose data and curves of normal people, pre-diabetes patients, and severe diabetes patients, they have remarkable resemblance. His elastic glucose data and curve are sitting between the normal case and the pre-diabetes case, while his plastic glucose data and curve are similar to severe diabetes case.

In his plastic glucose study of NPGT, he has developed the following simplified plastic glucose equation:

$$\text{Predicted PPG} = (\text{carbs\&sugar grams}) * \text{GH.e} + (\text{carbs\&sugar grams}) * \text{GH.p} + (\text{post-meal walking k-steps} * \text{GH.w})$$

Where: GH.e-Modulus can estimate the first elastic peak PPG at 60-minutes after a meal using carbs&sugar grams;

GH.p-Modulus can estimate the second elasto-plastic peak PPG at 120-minutes after a meal using the same value of carbs&sugar grams;

GH.w-Modulus can estimate the decreased PPG at 180-minutes after a meal using post-meal walking k-steps.

It should be noted that his plastic slope, GH.p-Modulus value of 0.254, is less than half or at the 43% level of his elastic slope, GH.e-Modulus value of 0.586.

To offer a simple explanation to readers who do not have a physics or engineering background, the author includes a brief excerpt from Wikipedia regarding the description of basic concept of viscoelasticity

theory and viscoplasticity theory from the disciplines of engineering and physics in the method section.

The analogy between physics and medicine are two-fold. First, the force or stress (y-axis) in physics and engineering corresponds to the influential force or load on our body for pushing PPG upward or dragging PPG downward in medicine due to the combined effect of carbohydrates and sugar intake amount and post-meal walking exercise. This stress component has no difference between elastic and plastic. Second, the deformation or strain (x-axis) in physics and engineering corresponds to the actual PPG level in medicine. This strain component has difference between elastic glucose and plastic glucose.

However, the medical field is still quite different from the engineering field, where the engineering materials such as steel, copper, concrete, and aluminum are inorganic material in most cases. These material properties do not change significantly over their expected lifespans. However, in medicine, the body with its organs and cells are organic material and go through many distinct stages over their natural lifespans, such as birth, splitting, growth, mutation, development, repair, sickness, and death. Therefore, the biomedical properties are “moving targets” which vary with the individual person, severity of diabetes, and selected different time-windows. In another word, they are both time-dependent and specimen-dependent. Because of these fundamental characteristics, calculations of cross-section of subject and calculation of bending moment of resistance, or the shape-factors, etc. in solid mechanics are not applicable in this biomedical elasticity/plasticity or viscoelasticity study. The most important part, in the author’s opinion, is that by applying the concept of plasticity theory or viscoelasticity theory on understanding the biomedical phenomena is extremely useful for exploring deep insights for predicting abnormal glucose behaviors in order to help the 100+ million diabetes patients or 1.3% of the world population of 7.9 billion who are currently suffering from hyperglycemia (i.e., high glucose level > 180 mg/dL).

1.2 Energy theory

After declaring the analogy of elasticity and plasticity theories, the energy theory in physics must be brought into context. The human body and organs are composed of different organic cells that require energy infusion from glucose carried by red blood cells; and energy consumption from labor-work or exercise. When the residual energy resulted from plastic glucose scenario is stored inside of our bodies, it will cause different degrees of damage to many internal organs.

According to physics, energies associated with the residual glucose waves are proportional to the square of the residual glucose amplitude. The residual energies from elevated glucoses are circulating inside the body via blood vessels which then impact all of the internal organs to cause different degrees of damage, i.e. diabetic complications. The author has applied Fast Fourier Transform (FFT) operations to convert the glucose wave from a time-domain into a frequency-domain. The y-axis amplitude values in the frequency-domain indicate the proportional energy levels associated with each different frequency component of glucose occurrence. Actually, both glucose value (i.e. strain amplitude in time-domain) and glucose fluctuation rate (i.e. the strain rate and strain frequency) are influencing the energy level (i.e. the Y-amplitude in frequency domain).

Currently, many people live a sedentary lifestyle and lack sufficient exercise to burn off the energy influx which causes them to become overweight or obese. Overweight and obesity lead into chronic diseases, including diabetes. In addition, many types of processed food add unnecessary ingredients and harmful chemicals that are toxic to the bodies, which lead to the development of many other deadly diseases, such as cancers. For example, there are ~85% of worldwide diabetes patients who are overweight, and there are ~75% of patients of cardiac illnesses or surgeries have diabetes conditions.

In engineering analysis, when the load is applied on the structure, it bends or twists, i.e. deforms; however, when the load is removed, it will either be restored (i.e. elastic) or remain in a permanent deformed shape (i.e. plastic) with plastic hinges. In a

corresponding biomedical analysis, after eating carbohydrates or sugar from food, our glucose level will increase; therefore, the sugar and carbohydrates function as the energy supply. After having labor work or exercise, the glucose level will decrease. As a result, the exercise burns off the energy, which is similar to load removal in the engineering case. In the biomedical case, both of the energy influx and energy consumption processes take some time which are not as simple and quick as the structural load removal in the engineering case. Therefore, the glucose behaviors, for both elastic glucose and plastic glucose, are “dynamic” in nature, i.e., time-dependent. This time-dependent nature leads into “visco-elastic or viscoplastic” situation.

1.3 Time-dependent strain (glucose) and stress of (viscosity*glucose rate)

The Hooke’s law of linear elasticity is expressed as:

$$\text{Strain } (\epsilon: \text{epsilon}) = \text{Stress } (\sigma: \text{sigma}) / \text{Young's modulus } (E)$$

For biomedical glucose application, his developed linear elastic glucose theory (LEGT) is expressed as:

$$\text{PPG (strain)} = \text{carbs/sugar (stress)} * \text{GH.p-Modulus (a positive number)} + \text{post-meal walking k-steps} * \text{GH.w-Modulus (a negative number)}$$

Where GH.p-Modulus is reciprocal of Young’s modulus E.

However, in viscoelasticity theory, the stress is expressed as:

$$\text{Stress} = \text{viscosity factor } (\eta: \text{eta}) * \text{strain rate } (d\epsilon/dt)$$

Where strain is expressed as Greek epsilon or ϵ .

In this article, in order to construct an “ellipse-like” diagram in stress-strain space domain (e.g. “hysteresis loop”) covering both positive side and negative side of the space, he has modified his definition of strain as follows:

$$\text{Strain} = (\text{PPG value at certain time instant}) - (\text{averaged PPG value})$$

He also calculates his strain rate using the following formula:

$$\text{Strain rate} = (\text{PPG at next time instant} - \text{PPG at current time instant}) / 15$$

Where 15 indicates the 15 minutes time span of his CGM sensor glucose measurement.

In order to study the impact on the viscoelastic hysteresis loop size (i.e. loop area) resulted from two different viscosity factors (η : eta), he has selected 1 for the lower viscosity case and 6 for the higher viscosity case. Please note that his average carbs/sugar intake amounts for elastic versus plastic cases are 13.5 grams versus 85.7 grams which is a ratio of 1.0 to 6.3.

The objective of this particular article is to explore certain basic characteristics of viscoelasticity using the author’s own collected elastic glucose (<180 mg/dL) data during a long period from 5/8/2018 to 1/10/2022. These explored some glucose characteristics using the viscoelastic or viscoplastic glucose theory (VGT) include stress relaxation, creep, hysteresis loop, material stiffness, damping effect based on time-dependent stress and strain which are different from his previous research findings using linear elastic glucose theory (LEGT) and nonlinear plastic glucose theory (NPGT). Actually, the hysteresis loops area of energy loss via heat has some connection with both energy theory and thermodynamics as well.

2. METHODS

2.1 Elasticity, plasticity, viscoelasticity and viscoplasticity

The difference between elastic materials and viscoelastic materials (from “Soborthans, innovating shock and vibration solutions”)

What are elastic materials?

Elasticity is the tendency of solid materials to return to their original shape after forces are applied on them. When the forces are removed, the object will return to its initial shape and size if the material is elastic.

What are viscous materials?

Viscosity is a measure of a fluid’s resistance to flow. A fluid with large viscosity resists

motion. A fluid with low viscosity flows. For example, water flows more easily than syrup because it has a lower viscosity. High viscosity materials might include honey, syrups, or gels – generally things that resist flow. Water is a low viscosity material, as it flows readily. Viscous materials are thick or sticky or adhesive. Since heating reduces viscosity, these materials don't flow easily. For example, warm syrup flows more easily than cold.

What is viscoelastic?

Viscoelasticity is the property of materials that exhibit both viscous and elastic characteristics when undergoing deformation. Synthetic polymers, wood, and human tissue, as well as metals at high temperature, display significant viscoelastic effects. In some applications, even a small viscoelastic response can be significant.

Elastic behavior versus viscoelastic behavior

The difference between elastic materials and viscoelastic materials is that viscoelastic materials have a viscosity factor and the elastic ones don't. Because viscoelastic materials have the viscosity factor, they have a strain rate dependent on time. Purely elastic materials do not dissipate energy (heat) when a load is applied, then removed; however, a viscoelastic substance does.

The following brief introductions are excerpts from Wikipedia:

“Elasticity (physics):

Physical property when materials or objects return to original shape after deformation.

In physics and materials science, elasticity is the ability of a body to resist a distorting influence and to return to its original size and shape when that influence or force is removed. Solid objects will deform when adequate loads are applied to them; if the material is elastic, the object will return to its initial shape and size after removal. This is in contrast to plasticity, in which the object fails to do so and instead remains in its deformed state.

The physical reasons for elastic behavior can be quite different for different materials. In metals, the atomic lattice changes size and

shape when forces are applied (energy is added to the system). When forces are removed, the lattice goes back to the original lower energy state. For rubbers and other polymers, elasticity is caused by the stretching of polymer chains when forces are applied.

Hooke's law states that the force required to deform elastic objects should be directly proportional to the distance of deformation, regardless of how large that distance becomes. This is known as perfect elasticity, in which a given object will return to its original shape no matter how strongly it is deformed. This is an ideal concept only; most materials which possess elasticity in practice remain purely elastic only up to very small deformations, after which plastic (permanent) deformation occurs.

In engineering, the elasticity of a material is quantified by the elastic modulus such as the Young's modulus, bulk modulus or shear modulus which measure the amount of stress needed to achieve a unit of strain; a higher modulus indicates that the material is harder to deform. The material's elastic limit or yield strength is the maximum stress that can arise before the onset of plastic deformation.

Plasticity (physics):

Deformation of a solid material undergoing non-reversible changes of shape in response to applied forces.

In physics and materials science, plasticity, also known as plastic deformation, is the ability of a solid material to undergo permanent deformation, a non-reversible change of shape in response to applied forces. For example, a solid piece of metal being bent or pounded into a new shape displays plasticity as permanent changes occur within the material itself. In engineering, the transition from elastic behavior to plastic behavior is known as yielding.

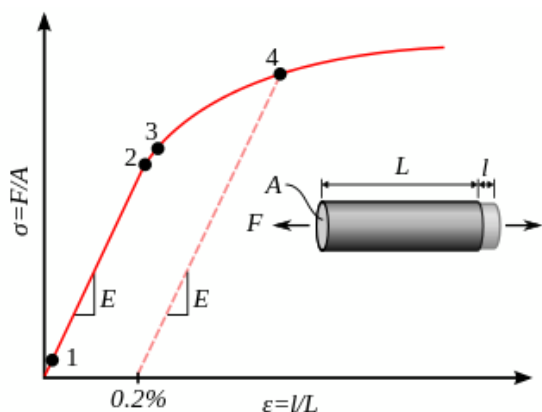

Stress–strain curve showing typical yield behavior for nonferrous alloys.

1. True elastic limit
2. Proportionality limit
3. Elastic limit
4. Offset yield strength

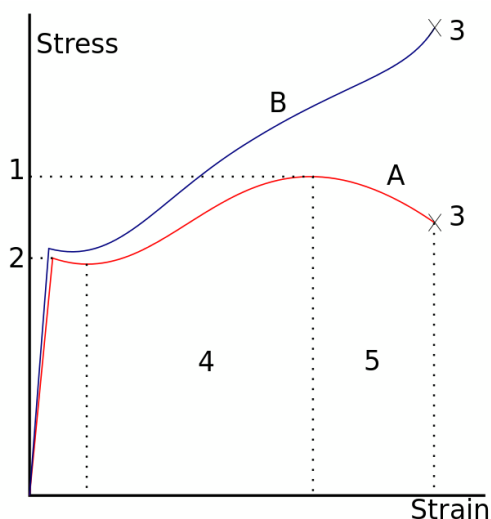

A stress–strain curve typical of structural steel.

- 1: Ultimate strength
- 2: Yield strength (yield point)
- 3: Rupture
- 4: Strain hardening region
- 5: Necking region
- A: Apparent stress (F/A_0)
- B: Actual stress (F/A)

Plastic deformation is observed in most materials, particularly metals, soils, rocks, concrete, and foams. However, the physical mechanisms that cause plastic deformation can vary widely. At a crystalline scale, plasticity in metals is usually a consequence of dislocations. Such defects are relatively

rare in most crystalline materials, but are numerous in some and part of their crystal structure; in such cases, plastic crystallinity can result. In brittle materials such as rock, concrete and bone, plasticity is caused predominantly by slip at microcracks. In cellular materials such as liquid foams or biological tissues, plasticity is mainly a consequence of bubble or cell rearrangements, notably T1 processes.

For many ductile metals, tensile loading applied to a sample will cause it to behave in an elastic manner. Each increment of load is accompanied by a proportional increment in extension. When the load is removed, the piece returns to its original size. However, once the load exceeds a threshold – the yield strength – the extension increases more rapidly than in the elastic region; now when the load is removed, some degree of extension will remain.

Elastic deformation, however, is an approximation and its quality depends on the time frame considered and loading speed. If, as indicated in the graph opposite, the deformation includes elastic deformation, it is also often referred to as "elasto-plastic deformation" or "elastic-plastic deformation".

Perfect plasticity is a property of materials to undergo irreversible deformation without any increase in stresses or loads. Plastic materials that have been hardened by prior deformation, such as cold forming, may need increasingly higher stresses to deform further. Generally, plastic deformation is also dependent on the deformation speed, i.e. higher stresses usually have to be applied to increase the rate of deformation. Such materials are said to deform viscoplastically."

Viscoelasticity:

Property of materials with both viscous and elastic characteristics under deformation.

In materials science and continuum mechanics, viscoelasticity is the property of materials that exhibit both viscous and elastic characteristics when undergoing deformation. Viscous materials, like water, resist shear flow and strain linearly with time when a stress is applied. Elastic materials strain when stretched and

immediately return to their original state once the stress is removed.

Viscoelastic materials have elements of both of these properties and, as such, exhibit time-dependent strain. Whereas elasticity is usually the result of bond stretching along crystallographic planes in an ordered solid, viscosity is the result of the diffusion of atoms or molecules inside an amorphous material.

In the nineteenth century, physicists such as Maxwell, Boltzmann, and Kelvin researched and experimented with creep and recovery of glasses, metals, and rubbers. Viscoelasticity was further examined in the late twentieth century when synthetic polymers were engineered and used in a variety of applications. Viscoelasticity calculations depend heavily on the viscosity variable, η . The inverse of η is also known as fluidity, ϕ . The value of either can be derived as a function of temperature or as a given value (i.e. for a dashpot).

Depending on the change of strain rate versus stress inside a material, the viscosity can be categorized as having a linear, non-linear, or plastic response. When a material exhibits a linear response it is categorized as a Newtonian material. In this case the stress is linearly proportional to the strain rate. If the material exhibits a non-linear response to the strain rate, it is categorized as Non-Newtonian fluid. There is also an interesting case where the viscosity decreases as the shear/strain rate remains constant. A material which exhibits this type of behavior is known as thixotropic. In addition, when the stress is independent of this strain rate, the material exhibits plastic deformation. Many viscoelastic materials exhibit rubber like behavior explained by the thermodynamic theory of polymer elasticity.

Cracking occurs when the strain is applied quickly and outside of the elastic limit. Ligaments and tendons are viscoelastic, so the extent of the potential damage to them depends both on the rate of the change of their length as well as on the force applied.

A viscoelastic material has the following properties:

- hysteresis is seen in the stress–strain curve

- stress relaxation occurs: step constant strain causes decreasing stress
- creep occurs: step constant stress causes increasing strain
- its stiffness depends on the strain rate or the stress rate.

Elastic versus viscoelastic behavior

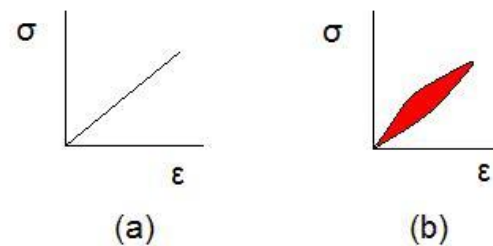

Stress–strain curves for a purely elastic material (a) and a viscoelastic material (b). The red area is a hysteresis loop and shows the amount of energy lost (as heat) in a loading and unloading cycle. It is equal to

$$\oint \sigma d\epsilon,$$

where σ is stress and ϵ is strain.

Unlike purely elastic substances, a viscoelastic substance has an elastic component and a viscous component. The viscosity of a viscoelastic substance gives the substance a strain rate dependence on time. Purely elastic materials do not dissipate energy (heat) when a load is applied, then removed. However, a viscoelastic substance dissipates energy when a load is applied, then removed. Hysteresis is observed in the stress–strain curve, with the area of the loop being equal to the energy lost during the loading cycle. Since viscosity is the resistance to thermally activated plastic deformation, a viscous material will lose energy through a loading cycle. Plastic deformation results in lost energy, which is uncharacteristic of a purely elastic material's reaction to a loading cycle.

Specifically, viscoelasticity is a molecular rearrangement. When a stress is applied to a viscoelastic material such as a polymer, parts of the long polymer chain change positions. This movement or rearrangement is called “creep”. Polymers remain a solid material even when these parts of their chains are rearranging in order to accompany the stress, and as this occurs, it creates a back stress in

the material. When the back stress is the same magnitude as the applied stress, the material no longer creeps. When the original stress is taken away, the accumulated back stresses will cause the polymer to return to its original form. The material creeps, which gives the prefix visco-, and the material fully recovers, which gives the suffix -elasticity.

Viscoplasticity:

Viscoplasticity is a theory in continuum mechanics that describes the rate-dependent inelastic behavior of solids. Rate-dependence in this context means that the deformation of the material depends on the rate at which loads are applied. The inelastic behavior that is the subject of viscoplasticity is plastic deformation which means that the material undergoes unrecoverable deformations when a load level is reached. Rate-dependent plasticity is important for transient plasticity calculations. The main difference between rate-independent plastic and viscoplastic material models is that the latter exhibit not only permanent deformations after the application of loads but continue to undergo a creep flow as a function of time under the influence of the applied load.

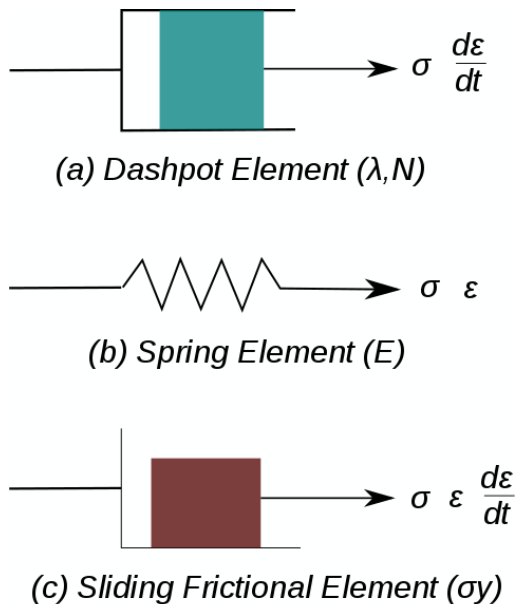

Figure 1. Elements used in one-dimensional models of viscoplastic materials.

The elastic response of viscoplastic materials can be represented in one-dimension by Hookean spring elements. Rate-dependence can be represented by nonlinear dashpot elements in a manner similar to viscoelasticity. Plasticity can be accounted for

by adding sliding frictional elements as shown in Figure 1. In the figure E is the modulus of elasticity, λ is the viscosity parameter and N is a power-law type parameter that represents non-linear dashpot [$\sigma(d\epsilon/dt) = \sigma = \lambda(d\epsilon/dt)^{1/N}$]. The sliding element can have a yield stress (σ_y) that is strain rate dependent, or even constant, as shown in Figure 1c.

Viscoplasticity is usually modeled in three-dimensions using overstress models of the Perzyna or Duvaut-Lions types. In these models, the stress is allowed to increase beyond the rate-independent yield surface upon application of a load and then allowed to relax back to the yield surface over time. The yield surface is usually assumed not to be rate-dependent in such models. An alternative approach is to add a strain rate dependence to the yield stress and use the techniques of rate independent plasticity to calculate the response of a material.

For metals and alloys, viscoplasticity is the macroscopic behavior caused by a mechanism linked to the movement of dislocations in grains, with superposed effects of inter-crystalline gliding. The mechanism usually becomes dominant at temperatures greater than approximately one third of the absolute melting temperature. However, certain alloys exhibit viscoplasticity at room temperature (300K). For polymers, wood, and bitumen, the theory of viscoplasticity is required to describe behavior beyond the limit of elasticity or viscoelasticity.

In general, viscoplasticity theories are useful in areas such as

- the calculation of permanent deformations,
- the prediction of the plastic collapse of structures,
- the investigation of stability,
- crash simulations,
- systems exposed to high temperatures such as turbines in engines, e.g. a power plant,
- dynamic problems and systems exposed to high strain rates.

Phenomenology

For a qualitative analysis, several characteristic tests are performed to describe

the phenomenology of viscoplastic materials. Some examples of these tests are

1. hardening tests at constant stress or strain rate,
2. creep tests at constant force, and
3. stress relaxation at constant elongation.

Strain hardening test

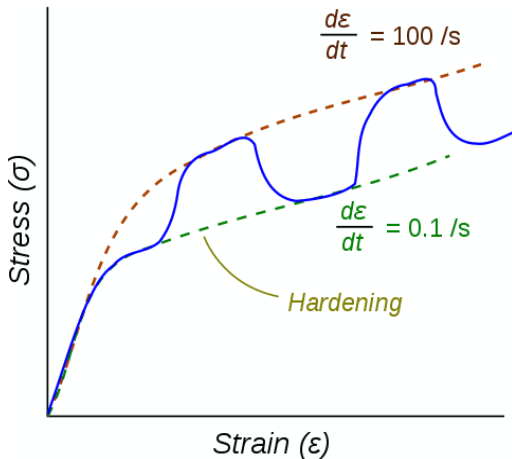

Figure 2. Stress–strain response of a viscoplastic material at different strain rates.

The dotted lines show the response if the strain-rate is held constant. The blue line shows the response when the strain rate is changed suddenly.

One consequence of yielding is that as plastic deformation proceeds, an increase in stress is required to produce additional strain. This phenomenon is known as Strain/Work hardening. For a viscoplastic material the hardening curves are not significantly different from those of rate-independent plastic material. Nevertheless, three essential differences can be observed.

1. At the same strain, the higher the rate of strain the higher the stress
2. A change in the rate of strain during the test results in an immediate change in the stress–strain curve.
3. The concept of a plastic yield limit is no longer strictly applicable.

The hypothesis of partitioning the strains by decoupling the elastic and plastic parts is still applicable where the strains are small, i.e.,

$$\epsilon = \epsilon_e + \epsilon_{vp}$$

where ϵ_e is the elastic strain and ϵ_{vp} is the viscoplastic strain.

To obtain the stress–strain behavior shown in blue in the figure, the material is initially loaded at a strain rate of 0.1/s. The strain rate is then instantaneously raised to 100/s and held constant at that value for some time. At the end of that time period the strain rate is dropped instantaneously back to 0.1/s and the cycle is continued for increasing values of strain. There is clearly a lag between the strain-rate change and the stress response. This lag is modeled quite accurately by overstress models (such as the Perzyna model) but not by models of rate-independent plasticity that have a rate-dependent yield stress.

3. RESULTS

Figure 1 shows time-domain waveforms and data table of both strain (PPG difference) and two stresses ($d\epsilon/dt$) using $\eta = 1$ & $\eta = 6$.

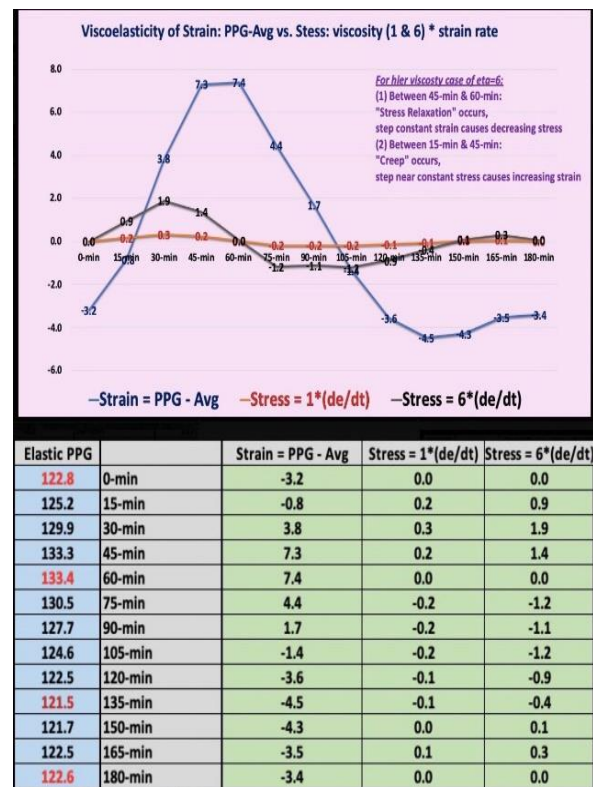

Figure 1: Time domain of PPG waveforms and data table of both strain and two stresses ($\eta = 1$ & $\eta = 6$).

Figure 2 depicts Space-domain of stress–strain diagram of two hysteresis loops using $\eta = 1$ & $\eta = 6$. For the case of $\eta = 6$, both of stiffness and damping are shown.

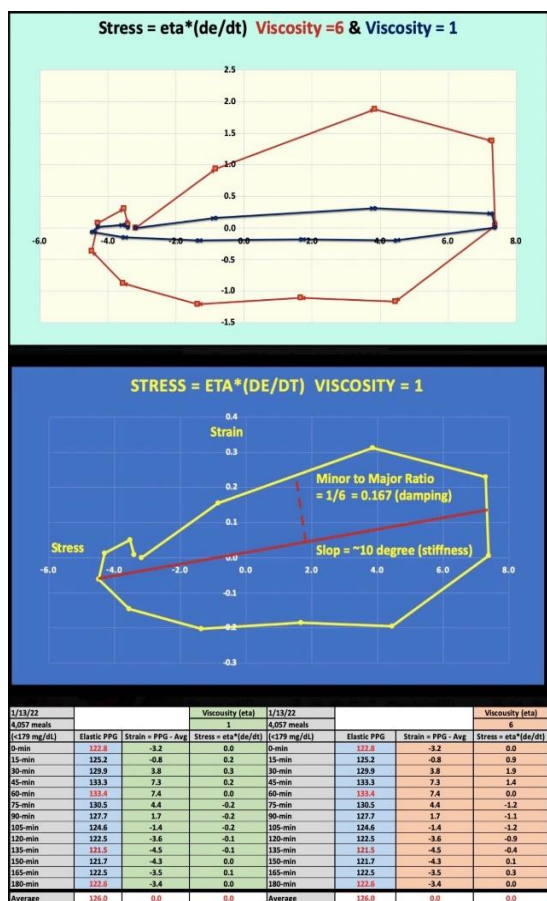

Figure 2: Space-domain of 2 hysteresis loop ($\eta = 1$ & 6), stiffness and damping using case of $\eta = 6$.

Figure 3 illustrates the comparison of both daily glucose curves and PPG curves among normal people, pre-diabetes patients, and severe diabetes patients (References 1 and 2).

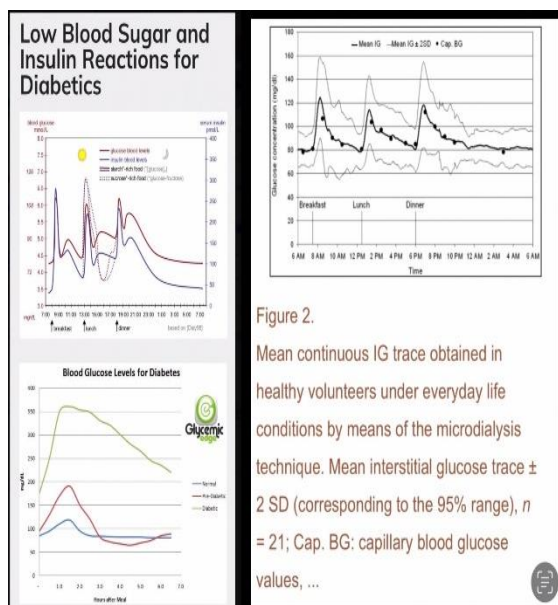

Figure 3: Daily glucose curve of healthy people and comparison of PPG curves among normal people, pre-diabetes patients, and severe diabetes patients (from References 1 and 2).

4. CONCLUSION

In summary, the following three concluding remarks have described the findings of this particular methodology paper.

(1) From time-domain diagram of both strain curve ($d\epsilon/dt$, or PPG difference) and higher viscous stress curve (viscosity factor $\eta=6 * PPG$ strain-rate), the data and curve between 45-minutes and 60-minutes explains the stress relaxation phenomenon (constant strain causes decreasing stress) while the data and curve between 15-minutes and 45-minutes explains the creep phenomenon (constant stress causes increasing strain).

(2) The hysteresis loop area size of higher viscosity ($\eta = 6$) is much larger than the hysteresis loop area size of lower viscosity ($\eta = 1$) which mean a higher viscous material would have more energy loss into heat.

(3) Using the hysteresis loop map of higher viscosity ($\eta = 6$) as a sample, he can estimate that this loop area has a slope of around 10 degree which is also the rough estimated value of glucose material stiffness. Furthermore, he also calculates the ratio of minor axis length over the major axis length at a value of 1.67 as the damping value of glucose.

5. ACKNOWLEDGEMENT

Without Professor Norman Jones at MIT as his academic advisor, the author would not be able to conduct this particular research project and also published 500+ medical research papers. The author has never forgotten his advice to him that he should always enhance his strength on foundations, such as mathematics and physics, in order to make further improvement and advancement. Professor Jones has also provided him a personal example of doing outstanding teaching and research jobs with an excellent work attitude, extreme dedication, and ultimate commitment to advancing both science and engineering.

6. REFERENCES

For editing purposes, the majority of the references in this paper, which are self-references, have been removed. Only references from other authors' published

sources remain. The bibliography of the author's original self-references can be viewed at www.eclaircmd.com.

Readers may use this article as long as the work is properly cited, and their use is educational and not for profit, and the author's original work is not altered.

- 1) Guido Freckmann, Sven Hagenlocher, Cornelia Haug, *Journal of Diabetes Science and Technology*, "Continuous glucose profiles in healthy subjects under everyday life conditions and after different meals".
- 2) Glycemic Edge: <https://www.glycemicedge.com>.