

The GH-Method

Viscoelastic and Viscoplastic Glucose Theory (VGT #11): from Time-Domain Through Space-Domain to Frequency-Domain to Analyze and Study Glucose Characters and Behaviors of Two Collected Postprandial Plasma Glucose (PPG) Datasets for the PPG Level <120 mg/dL versus >150 mg/dL Using Elasticity & Plasticity Theory (Time-Independent), and Viscoelasticity & Viscoplasticity Theory (Time-Dependent) Based on GH-Method: Math-Physical Medicine (No. 590)

Gerald C. Hsu*

eclairMD Foundation, USA

Note: Readers who want to get a quick overview can read the abstract, results, and graphs.

Abstract

The author has studied strength of materials and theory of elasticity through his undergraduate courses at the University of Iowa. He then conducted research work to earn a master's degree in Biomechanics under Professor James Andrews. At that time, he used the spring and dashpot models to simulate the behaviors of human joints, bones, muscles, and tendons in order to investigate the human-weapon interactions during the Vietnam war. Later, he went to MIT to pursue his PhD study under Professor Norman Jones, who taught him theory of plasticity and dynamic plastic behaviors of various structure elements. He also took additional graduate courses in the field of fluid dynamics and thermodynamics. Since then, many advancements have been made in the biomechanics branch, especially with human body tissues that possess viscoelastic characteristics, such as bones, muscles, cartilages, tendons (connect bone to muscle), ligaments (connect bone to bone), fascia, and skin. For example, the author suffered plantar fasciitis for many years. He understood that the night splint dorsiflexes forefoot, at the back of the foot, increases plantar fascia tension to offer stress-relaxation for the pain. This model of muscles and tendons connecting the lower leg and foot is a kind of viscoelastic study and biomedical problem solving. However, when dealing with human internal organs, it is not easy to conduct live experiments to obtain accurate measurements for the biomedical material properties. Although blood is a viscous (time-dependent) material, its viscosity factor may fall between water, honey,

or syrup, or gel. The author's research subject is "glucose" where the carbohydrates and sugar amount is produced by the liver and is carried by red blood cells, not the blood itself. It is nearly impossible to measure material geometry or certain engineering properties of glucose, for example, to determine the viscosity of "glucose". Therefore, the best he could do is to apply the "concept of viscoelasticity and/or viscoplasticity" to construct an analogy model of time-dependent glucose behaviors. The author's background includes mathematics, physics, and various engineering disciplines, not including biology and chemistry. As a result, he can only investigate the observed biomedical phenomena using his ready-learned math-physical tools. For example, he studied both modern physics and quantum mechanics during his school days. Therefore, he attempted to apply the theory of relativity on interactions among human organs in the inner space, human body, which is similar to inter-relationships among various planets in outer space or in the universe. Furthermore, he applied the perturbation theory to obtain an approximate but yet accurate enough of predicted glucose level along with the estimation of associated energy of glucose. In addition, he has conducted some investigations of glucose behaviors using elasticity theory and plasticity theory, which allowed him to write a few articles on his research findings. In the elasticity and plasticity papers, he utilized the postprandial plasma glucose (PPG) value as the strain along with the combined effect of both carbs/sugar intake amount and post-meal exercise level as the stress. In a recent email from Professor

Received: 09 February 2022, Accepted: 03 March 2022, Available online: 10 March 2022

*Corresponding author: Gerald C. Hsu, eclairMD Foundation, USA

Norman Jones, he said that: "I have wondered if the use of viscoelastic/viscoplastic materials might be of some value to your studies. These phenomena embrace time-dependent behaviour and I know that you have emphasized the time-dependence of various behaviours in the body. Just a thought." His suggestion triggered the author's strong interest and desire to research this subject of glucose behaviors further by using the viscosity theory. This article is a follow-up to his previous 10 papers using viscoelasticity or viscoplastic glucose theory (VGT). In this paper, the author uses a set of his collected continuous glucose monitoring (CGM) sensor PPG data and waveforms, where he separated them into two glucose groups: < 120 mg/dL (normal condition from 3,187 meals with an average carbs/sugar of 11.1 grams) and >150 mg/dL (diabetes condition from 102 meals with an average carbs/sugar of 58.3 grams) to conduct a glucose behavior analysis in time-domain (TD) or PPG vs. time, space-domain (SD) or stress vs. strain, and frequency-domain (FD) or energy vs. PPG frequency. The author utilizes his own PPG value as the strain and the respective strain rate (de/dt) multiplied with the viscosity factor (η) as the stress. Since it is difficult for him to determine the viscosity factor (η) of glucose, not blood, he makes the bold assumption by using his carbs/sugar intake amounts (grams) for each PPG level as the viscosity factor. These two different carbs/sugar intake amounts, 11.1 grams vs. 58.3 grams, serve as his two viscosity factors (η) in the following defined stress and strain equations: Stress $\sigma = \text{viscosity factor} * (\text{present PPG} - \text{previous PPG}) / 15 = \eta * (de/dt)$. Strain $\epsilon = (\text{individual PPG value})$. The analogy between physics and medicine is twofold. First, the force or stress (σ) in physics and engineering (y-axis) corresponds to the influential force or load on our body for pushing PPG upward or downward in medicine, e.g. carbohydrates and sugar intake amount or post-meal walking exercise. The major influential force of stress is the selection of the viscosity factors (η). Another influential force is the deformation rate or strain rate (de/dt). Combining η and de/dt together, we get the stress which includes influences from both carbs/sugar intake and post-meal exercise. Nevertheless, the medical field is still quite different from the engineering field, where the engineering materials such as steel, copper, concrete, and aluminum are inorganic in most cases. These material properties do not change significantly over their expected lifespans. However, in medicine, the body with its organs and cells are organic and go through many distinct stages over their natural lifespans, such as birth, splitting, growth, mutation, development, repair, sickness, and death. Therefore, the biomedical properties are "moving targets" which vary with the individual person, severity of diabetes, and selected different time-windows. In other words, they are both time-dependent and specimen-dependent, because these fundamental

characteristics, calculations of cross-section of subject, bending moment of resistance, or the shape-factors in solid mechanics are not applicable in this biomedical glucose analogy study of elasticity / plasticity or viscoelasticity / viscoplasticity. The most important part, in the author's opinion, is that by applying the concept of elasticity / plasticity theory or viscoelasticity / viscoplasticity theory on understanding or illustrating the observed biomedical phenomena is extremely useful for exploring deep insights or for the prediction of glucoses, particularly for hyperglycemic situations (or severe diabetes cases which are similar to plastic behaviors) in order to help the 100+ million diabetes patients or 1.3% of the world population of 7.9 billion who are currently suffering from hyperglycemia (i.e., high glucose level > 180 mg/dL). In the engineering analysis, when the load is applied on the structure, it bends or twists becoming deformed; however, when the load is removed, it will either be restored back to its original shape (elastic) or remain in a permanent deformed shape (plastic). In its corresponding biomedical situation, after eating carbohydrates or sugar from food, our glucose level will increase; therefore, the sugar and carbohydrates function as the energy supply or energy influx. After having labor work or exercise, the glucose level will decrease. As a result, exercise burns off energy, which is similar to the unloading process in the engineering case. However, in the biomedical case, the energy input and output process take some time which is not as simple and quick as the structural load removal in the engineering case. Therefore, the glucose behaviors, for both elastic glucose and plastic glucose, are "dynamic" in nature which is "time-dependent". To offer a simple explanation to readers who do not have a physics or engineering background, the author includes a brief excerpt from Wikipedia regarding the description of basic concepts for elasticity and plasticity theories, viscoelasticity and viscoplasticity theories from the disciplines of engineering and physics in the method section. In conclusion, the author defines his strain and stress in the following equations: Strain $= \epsilon = \text{individual PPG value}$. Stress $= \sigma = \eta * (de/dt) = \eta * (d\text{-strain}/d\text{-time}) = \text{viscosity factor} * (\text{PPG at next time instant} - \text{PPG at current time instant}) / 15$, where 15 indicates the 15-minute timespan of his CGM sensor glucose measurement. He then uses 11.1 grams as the viscosity factor for the case of <120, and 58.3 grams as the viscosity factor for the case of >150. After generating two different hysteresis loops in the stress-strain diagram, he uses the formula of a trapezoid area to calculate the respective hysteresis loop areas which indicate the energy loss during the loading-unloading process on PPG. By applying the Fast Fourier Transform (FFT) operation, he can transform his PPG from TD into FD. He utilizes the following 3 energy equations to estimate the relative associated energy of PPG: Time-domain energy equation = summation of

square of Y-amplitude in TD, i.e. PPG; Frequency-domain equation 1 = summation of (square of Y-amplitude in FD) / (number of frequency components); Frequency-domain equation 2 = summation of ((square of Y-amplitude in FD) / 2) then multiplied by (number of frequency components). Based on the four theories of linear elasticity, plasticity, viscoelasticity, viscoplasticity in Engineering and energy theory in Physics, the following 3 distinct observations are evident: (1) By observing TD and SD analysis results, the case of <120 mg/dL is elastic and viscoelastic, while the case of >150 mg/dL is plastic and viscoplastic. The viscoelastic or viscoplastic state is a result of their time-dependency characteristic. The difference between elastic and plastic is a result from observing the amount of PPG difference between

0-minute and 90-180 minutes and judging if it has a permanent deformation or not. (2) The area ratio between <120 case (hysteresis loop area = 46) and >150 case (hysteresis loop area = 1202) is 26. This shows that the energy loss through the viscoplastic >150 case is 26 times higher than the viscoelastic <120 case. (3) The relative associated energy of PPG has a ratio of 1:1.9 between <120 vs. >150 from TD energy analysis; however, the relative associated energy of PPG has a ratio of 1:7.5 between <120 vs. >150 from FD energy analysis. This shows that the total energy carried by the hyperglycemic case (>150 mg/dL) is much higher than the normal case (<120 mg/dL); therefore, the hyperglycemia will cause a higher degree of damage on the internal organs.

Keywords: Viscoelastic; Viscoplastic; Elasticity; Plasticity; Postprandial plasma glucose

Abbreviations: PPG: postprandial plasma glucose; MPM: math-physical medicine; CGM: continuous glucose monitoring; TD: time-domain; SD: space-domain; FD: frequency-domain

1. INTRODUCTION

The author has studied strength of materials and theory of elasticity through his undergraduate courses at the University of Iowa. He then conducted research work to earn a master's degree in Biomechanics under Professor James Andrews. At that time, he used the spring and dashpot models to simulate the behaviors of human joints, bones, muscles, and tendons in order to investigate the human-weapon interactions during the Vietnam war. Later, he went to MIT to pursue his PhD study under Professor Norman Jones, who taught him theory of plasticity and dynamic plastic behaviors of various structure elements. He also took additional graduate courses in the field of fluid dynamics and thermodynamics.

Since then, many advancements have been made in the biomechanics branch, especially with human body tissues that possess viscoelastic characteristics, such as bones, muscles, cartilages, tendons (connect bone to muscle), ligaments (connect bone to bone), fascia, and skin. For example, the author suffered plantar fasciitis for many years. He understood that the night splint dorsiflexes forefoot, at the back of the foot, increases plantar fascia tension to offer stress-relaxation for the pain. This model of muscles and tendons connecting the lower leg and foot is a kind of viscoelastic study and biomedical problem solving. However, when dealing with human internal organs, it is not easy to conduct live experiments to obtain accurate measurements for the biomedical material properties. Although blood is a viscous (time-dependent) material, its viscosity factor may fall between water, honey, syrup, or gel. The author's research subject is "glucose" where the carbohydrates and sugar amount is produced by the liver and is carried by red blood cells, not the blood itself. It is nearly impossible to measure material geometry or certain engineering properties of glucose, for example, to determine the viscosity of "glucose". Therefore, the best he could do is to apply the "concept of viscoelasticity and/or viscoplasticity" to construct an analogy model of time-dependent glucose behaviors.

The author's background includes mathematics, physics, and various engineering disciplines, not including biology

and chemistry. As a result, he can only investigate the observed biomedical phenomena using his ready-learned math-physical tools. For example, he studied both modern physics and quantum mechanics during his school days. Therefore, he attempted to apply the theory of relativity on interactions among human organs in the inner space, human body, which is similar to inter-relationships among various planets in outer space or in the universe. Furthermore, he applied the perturbation theory to obtain an approximate but yet accurate enough of predicted glucose level along with the estimation of associated energy of glucose. In addition, he has conducted some investigations of glucose behaviors using elasticity theory and plasticity theory, which allowed him to write a few articles on his research findings. In the elasticity and plasticity papers, he utilized the postprandial plasma glucose (PPG) value as the strain along with the combined effect of both carbs/sugar intake amount and post-meal exercise level as the stress.

In a recent email from Professor Norman Jones, he said that: "I have wondered if the use of viscoelastic/viscoplastic materials might be of some value to your studies. These phenomena embrace time-dependent behaviour and I know that you have emphasized the time-dependence of various behaviours in the body. Just a thought." His suggestion triggered the author's strong interest and desire to research this subject of glucose behaviors further by using the viscosity theory. This article is a follow-up to his previous 10 papers using viscoelasticity or viscoplastic glucose theory (VGT).

In this paper, the author uses a set of his collected continuous glucose monitoring (CGM) sensor PPG data and waveforms, where he separated them into two glucose groups: < 120 mg/dL (normal condition from 3,187 meals with an average carbs/sugar of 11.1 grams) and >150 mg/dL (diabetes condition from 102 meals with an average carbs/sugar of 58.3 grams) to conduct a glucose behavior analysis in time-domain (TD) or PPG vs. time, space-domain (SD) or stress vs. strain, and frequency-domain (FD) or energy vs. PPG frequency.

The author utilizes his own PPG value as the strain and the respective strain rate ($d\epsilon/dt$)

multiplied with the viscosity factor (η) as the stress. Since it is difficult for him to determine the viscosity factor (η) of glucose, not blood, he makes the bold assumption by using his carbs/sugar intake amounts (grams) for each PPG level as the viscosity factor.

These two different carbs/sugar intake amounts, 11.1 grams vs. 58.3 grams, serve as his two viscosity factors (η) in the following defined stress and strain equations:

Stress σ
 = viscosity factor * (present PPG - previous PPG) / 15
 = $\eta * (d\epsilon/dt)$

Strain ϵ
 = (individual PPG value)

The analogy between physics and medicine is twofold. First, the force or stress (σ) in physics and engineering (y-axis) corresponds to the influential force or load on our body for pushing PPG upward or downward in medicine, e.g. carbohydrates and sugar intake amount or post-meal walking exercise. The major influential force of stress is the selection of the viscosity factors (η). Another influential force is the deformation rate or strain rate ($d\epsilon/dt$). Combining η and $d\epsilon/dt$ together, we get the stress which includes influences from both carbs/sugar intake and post-meal exercise.

Nevertheless, the medical field is still quite different from the engineering field, where the engineering materials such as steel, copper, concrete, and aluminum are inorganic in most cases. These material properties do not change significantly over their expected lifespans. However, in medicine, the body with its organs and cells are organic and go through many distinct stages over their natural lifespans, such as birth, splitting, growth, mutation, development, repair, sickness, and death. Therefore, the biomedical properties are “moving targets” which vary with the individual person, severity of diabetes, and selected different time-windows. In other words, they are both time-dependent and specimen-dependent, because these fundamental characteristics, calculations of cross-section of subject, bending moment of resistance, or the shape-factors in solid mechanics are not applicable in this

biomedical glucose analogy study of elasticity / plasticity or viscoelasticity / viscoplasticity. The most important part, in the author’s opinion, is that by applying the concept of elasticity / plasticity theory or viscoelasticity / viscoplasticity theory on understanding or illustrating the observed biomedical phenomena is extremely useful for exploring deep insights or for the prediction of glucoses, particularly for hyperglycemic situations (or severe diabetes cases which are similar to plastic behaviors) in order to help the 100+ million diabetes patients or 1.3% of the world population of 7.9 billion who are currently suffering from hyperglycemia (i.e., high glucose level > 180 mg/dL).

In the engineering analysis, when the load is applied on the structure, it bends or twists becoming deformed; however, when the load is removed, it will either be restored back to its original shape (elastic) or remain in a permanent deformed shape (plastic). In its corresponding biomedical situation, after eating carbohydrates or sugar from food, our glucose level will increase; therefore, the sugar and carbohydrates function as the energy supply or energy influx. After having labor work or exercise, the glucose level will decrease. As a result, exercise burns off energy, which is similar to the unloading process in the engineering case. However, in the biomedical case, the energy input and output process take some time which is not as simple and quick as the structural load removal in the engineering case. Therefore, the glucose behaviors, for both elastic glucose and plastic glucose, are “dynamic” in nature which is “time-dependent”.

To offer a simple explanation to readers who do not have a physics or engineering background, the author includes a brief excerpt from Wikipedia regarding the description of basic concepts for elasticity and plasticity theories, viscoelasticity and viscoplasticity theories from the disciplines of engineering and physics in the method section.

2. METHODS

2.1 Elasticity, plasticity, viscoelasticity and viscoplasticity

The difference between elastic materials and viscoelastic materials (from “Soborthans, innovating shock and vibration solutions”).

What are elastic materials?

Elasticity is the tendency of solid materials to return to their original shape after forces are applied on them. When the forces are removed, the object will return to its initial shape and size if the material is elastic.

What are viscous materials?

Viscosity is a measure of a fluid's resistance to flow. A fluid with large viscosity resists motion. A fluid with low viscosity flows. For example, water flows more easily than syrup because it has a lower viscosity. High viscosity materials might include honey, syrups, or gels – generally things that resist flow. Water is a low viscosity material, as it flows readily. Viscous materials are thick or sticky or adhesive. Since heating reduces viscosity, these materials don't flow easily. For example, warm syrup flows more easily than cold.

What is viscoelastic?

Viscoelasticity is the property of materials that exhibit both viscous and elastic characteristics when undergoing deformation. Synthetic polymers, wood, and human tissue, as well as metals at high temperature, display significant viscoelastic effects. In some applications, even a small viscoelastic response can be significant.

Elastic behavior versus viscoelastic behavior

The difference between elastic materials and viscoelastic materials is that viscoelastic materials have a viscosity factor and the elastic ones don't. Because viscoelastic materials have the viscosity factor, they have a strain rate dependent on time. Purely elastic materials do not dissipate energy (heat) when a load is applied, then removed; however, a viscoelastic substance does.

The following brief introductions are excerpts from Wikipedia:

“Elasticity (physics):

Physical property when materials or objects return to original shape after deformation.

In physics and materials science, elasticity is the ability of a body to resist a distorting influence and to return to its original size and

shape when that influence or force is removed. Solid objects will deform when adequate loads are applied to them; if the material is elastic, the object will return to its initial shape and size after removal. This is in contrast to plasticity, in which the object fails to do so and instead remains in its deformed state.

The physical reasons for elastic behavior can be quite different for different materials. In metals, the atomic lattice changes size and shape when forces are applied (energy is added to the system). When forces are removed, the lattice goes back to the original lower energy state. For rubbers and other polymers, elasticity is caused by the stretching of polymer chains when forces are applied.

Hooke's law states that the force required to deform elastic objects should be directly proportional to the distance of deformation, regardless of how large that distance becomes. This is known as perfect elasticity, in which a given object will return to its original shape no matter how strongly it is deformed. This is an ideal concept only; most materials which possess elasticity in practice remain purely elastic only up to very small deformations, after which plastic (permanent) deformation occurs.

In engineering, the elasticity of a material is quantified by the elastic modulus such as the Young's modulus, bulk modulus or shear modulus which measure the amount of stress needed to achieve a unit of strain; a higher modulus indicates that the material is harder to deform. The material's elastic limit or yield strength is the maximum stress that can arise before the onset of plastic deformation.

Plasticity (physics):

Deformation of a solid material undergoing non-reversible changes of shape in response to applied forces.

In physics and materials science, plasticity, also known as plastic deformation, is the ability of a solid material to undergo permanent deformation, a non-reversible change of shape in response to applied forces. For example, a solid piece of metal being bent or pounded into a new shape displays plasticity as permanent changes occur within the material itself. In engineering, the

transition from elastic behavior to plastic behavior is known as yielding.

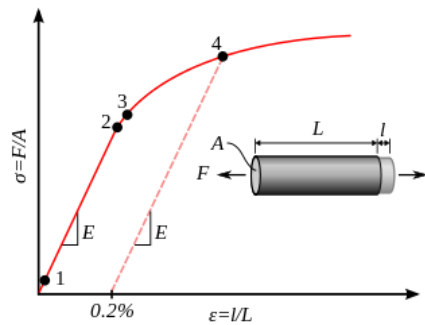

Stress–strain curve showing typical yield behavior for nonferrous alloys.

1. True elastic limit
2. Proportionality limit
3. Elastic limit
4. Offset yield strength

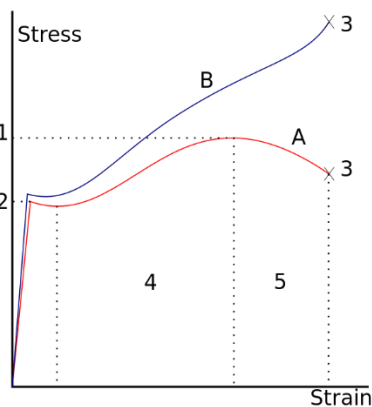

A stress–strain curve typical of structural steel.

- 1: Ultimate strength
- 2: Yield strength (yield point)
- 3: Rupture
- 4: Strain hardening region
- 5: Necking region
- A: Apparent stress (F/A_0)
- B: Actual stress (F/A)

Plastic deformation is observed in most materials, particularly metals, soils, rocks, concrete, and foams. However, the physical mechanisms that cause plastic deformation can vary widely. At a crystalline scale, plasticity in metals is usually a consequence of dislocations. Such defects are relatively rare in most crystalline materials, but are numerous in some and part of their crystal structure; in such cases, plastic crystallinity

can result. In brittle materials such as rock, concrete and bone, plasticity is caused predominantly by slip at microcracks. In cellular materials such as liquid foams or biological tissues, plasticity is mainly a consequence of bubble or cell rearrangements, notably T1 processes.

For many ductile metals, tensile loading applied to a sample will cause it to behave in an elastic manner. Each increment of load is accompanied by a proportional increment in extension. When the load is removed, the piece returns to its original size. However, once the load exceeds a threshold – the yield strength – the extension increases more rapidly than in the elastic region; now when the load is removed, some degree of extension will remain.

Elastic deformation, however, is an approximation and its quality depends on the time frame considered and loading speed. If, as indicated in the graph opposite, the deformation includes elastic deformation, it is also often referred to as "elasto-plastic deformation" or "elastic-plastic deformation".

Perfect plasticity is a property of materials to undergo irreversible deformation without any increase in stresses or loads. Plastic materials that have been hardened by prior deformation, such as cold forming, may need increasingly higher stresses to deform further. Generally, plastic deformation is also dependent on the deformation speed, i.e. higher stresses usually have to be applied to increase the rate of deformation. Such materials are said to deform viscoplastically."

Viscoelasticity:

Property of materials with both viscous and elastic characteristics under deformation.

In materials science and continuum mechanics, viscoelasticity is the property of materials that exhibit both viscous and elastic characteristics when undergoing deformation. Viscous materials, like water, resist shear flow and strain linearly with time when a stress is applied. Elastic materials strain when stretched and immediately return to their original state once the stress is removed.

Viscoelastic materials have elements of both of these properties and, as such, exhibit time-dependent strain. Whereas elasticity is usually the result of bond stretching along crystallographic planes in an ordered solid, viscosity is the result of the diffusion of atoms or molecules inside an amorphous material.

In the nineteenth century, physicists such as Maxwell, Boltzmann, and Kelvin researched and experimented with creep and recovery of glasses, metals, and rubbers. Viscoelasticity was further examined in the late twentieth century when synthetic polymers were engineered and used in a variety of applications. Viscoelasticity calculations depend heavily on the viscosity variable, η . The inverse of η is also known as fluidity, ϕ . The value of either can be derived as a function of temperature or as a given value (i.e. for a dashpot).

Depending on the change of strain rate versus stress inside a material, the viscosity can be categorized as having a linear, non-linear, or plastic response. When a material exhibits a linear response, it is categorized as a Newtonian material. In this case the stress is linearly proportional to the strain rate. If the material exhibits a non-linear response to the strain rate, it is categorized as non-Newtonian fluid. There is also an interesting case where the viscosity decreases as the shear/strain rate remains constant. A material which exhibits this type of behavior is known as thixotropic. In addition, when the stress is independent of this strain rate, the material exhibits plastic deformation. Many viscoelastic materials exhibit rubber like behavior explained by the thermodynamic theory of polymer elasticity.

Cracking occurs when the strain is applied quickly and outside of the elastic limit. Ligaments and tendons are viscoelastic, so the extent of the potential damage to them depends both on the rate of the change of their length as well as on the force applied.

A viscoelastic material has the following properties:

- hysteresis is seen in the stress–strain curve
- stress relaxation occurs: step constant strain causes decreasing stress

- creep occurs: step constant stress causes increasing strain
- its stiffness depends on the strain rate or the stress rate.

Elastic versus viscoelastic behavior

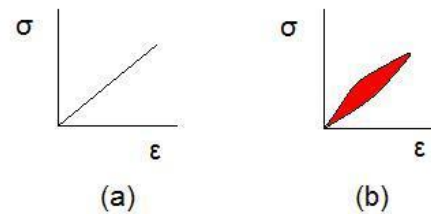

Stress–strain curves for a purely elastic material (a) and a viscoelastic material (b). The red area is a hysteresis loop and shows the amount of energy lost (as heat) in a loading and unloading cycle. It is equal to

$$\oint \sigma d\epsilon$$

where σ is stress and ϵ is strain.

Unlike purely elastic substances, a viscoelastic substance has an elastic component and a viscous component. The viscosity of a viscoelastic substance gives the substance a strain rate dependence on time. Purely elastic materials do not dissipate energy (heat) when a load is applied, then removed. However, a viscoelastic substance dissipates energy when a load is applied, then removed. Hysteresis is observed in the stress–strain curve, with the area of the loop being equal to the energy lost during the loading cycle. Since viscosity is the resistance to thermally activated plastic deformation, a viscous material will lose energy through a loading cycle. Plastic deformation results in lost energy, which is uncharacteristic of a purely elastic material's reaction to a loading cycle.

Specifically, viscoelasticity is a molecular rearrangement. When a stress is applied to a viscoelastic material such as a polymer, parts of the long polymer chain change positions. This movement or rearrangement is called “creep”. Polymers remain a solid material even when these parts of their chains are rearranging in order to accompany the stress, and as this occurs, it creates a back stress in the material. When the back stress is the same magnitude as the applied stress, the material no longer creeps. When the original stress is taken away, the accumulated back

stresses will cause the polymer to return to its original form. The material creeps, which gives the prefix visco-, and the material fully recovers, which gives the suffix -elasticity.

Viscoplasticity:

Viscoplasticity is a theory in continuum mechanics that describes the rate-dependent inelastic behavior of solids. Rate-dependence in this context means that the deformation of the material depends on the rate at which loads are applied. The inelastic behavior that is the subject of viscoplasticity is plastic deformation which means that the material undergoes unrecoverable deformations when a load level is reached. Rate-dependent plasticity is important for transient plasticity calculations. The main difference between rate-independent plastic and viscoplastic material models is that the latter exhibit not only permanent deformations after the application of loads but continue to undergo a creep flow as a function of time under the influence of the applied load.

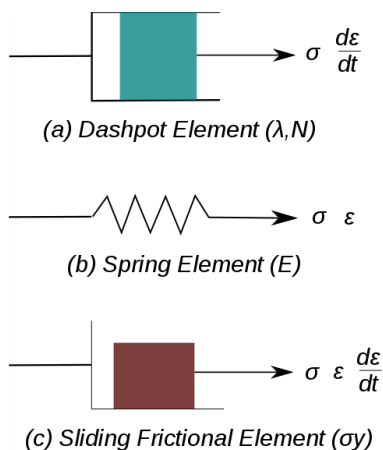

Figure 1. Elements used in one-dimensional models of viscoplastic materials.

The elastic response of viscoplastic materials can be represented in one-dimension by Hookean spring elements. Rate-dependence can be represented by nonlinear dashpot elements in a manner similar to viscoelasticity. Plasticity can be accounted for by adding sliding frictional elements as shown in Figure 1. In the figure E is the modulus of elasticity, λ is the viscosity parameter and N is a power-law type parameter that represents non-linear dashpot [$\sigma(d\epsilon/dt) = \sigma = \lambda(d\epsilon/dt)^{1/N}$]. The sliding element can have a yield stress (σ_y) that is strain rate dependent, or even constant, as shown in Figure 1c.

Viscoplasticity is usually modeled in three-dimensions using overstress models of the Perzyna or Duvaut-Lions types. In these models, the stress is allowed to increase beyond the rate-independent yield surface upon application of a load and then allowed to relax back to the yield surface over time. The yield surface is usually assumed not to be rate-dependent in such models. An alternative approach is to add a strain rate dependence to the yield stress and use the techniques of rate independent plasticity to calculate the response of a material.

For metals and alloys, viscoplasticity is the macroscopic behavior caused by a mechanism linked to the movement of dislocations in grains, with superposed effects of inter-crystalline gliding. The mechanism usually becomes dominant at temperatures greater than approximately one third of the absolute melting temperature. However, certain alloys exhibit viscoplasticity at room temperature (300K). For polymers, wood, and bitumen, the theory of viscoplasticity is required to describe behavior beyond the limit of elasticity or viscoelasticity.

In general, viscoplasticity theories are useful in areas such as

- the calculation of permanent deformations,
- the prediction of the plastic collapse of structures,
- the investigation of stability,
- crash simulations,
- systems exposed to high temperatures such as turbines in engines, e.g. a power plant,
- dynamic problems and systems exposed to high strain rates.

Phenomenology

For a qualitative analysis, several characteristic tests are performed to describe the phenomenology of viscoplastic materials. Some examples of these tests are

1. hardening tests at constant stress or strain rate,
2. creep tests at constant force, and
3. stress relaxation at constant elongation.

Strain hardening test

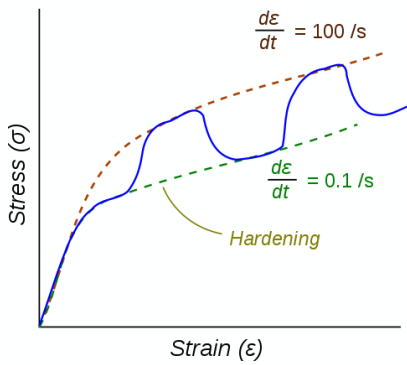

Figure 2. Stress–strain response of a viscoplastic material at different strain rates.

The dotted lines show the response if the strain-rate is held constant. The blue line shows the response when the strain rate is changed suddenly.

One consequence of yielding is that as plastic deformation proceeds, an increase in stress is required to produce additional strain. This phenomenon is known as Strain/Work hardening. For a viscoplastic material the hardening curves are not significantly different from those of rate-independent plastic material. Nevertheless, three essential differences can be observed.

1. At the same strain, the higher the rate of strain the higher the stress.
2. A change in the rate of strain during the test results in an immediate change in the stress–strain curve.
3. The concept of a plastic yield limit is no longer strictly applicable.

The hypothesis of partitioning the strains by decoupling the elastic and plastic parts is still applicable where the strains are small, i.e.,

$$\epsilon = \epsilon_e + \epsilon_{vp}$$

where ϵ_e is the elastic strain and ϵ_{vp} is the viscoplastic strain.

To obtain the stress–strain behavior shown in blue in the figure, the material is initially loaded at a strain rate of 0.1/s. The strain rate is then instantaneously raised to 100/s and held constant at that value for some time. At the end of that time period the strain rate is dropped instantaneously back to 0.1/s and the cycle is continued for increasing values of strain. There is clearly a lag between the strain-rate change and the stress response.

This lag is modeled quite accurately by overstress models (such as the Perzyna model) but not by models of rate-independent plasticity that have a rate-dependent yield stress.”

3. RESULTS

Figure 1 depicts the time-domain PPG waveforms of two selected PPG levels (upper diagram) and the data table of this analysis (lower diagram).

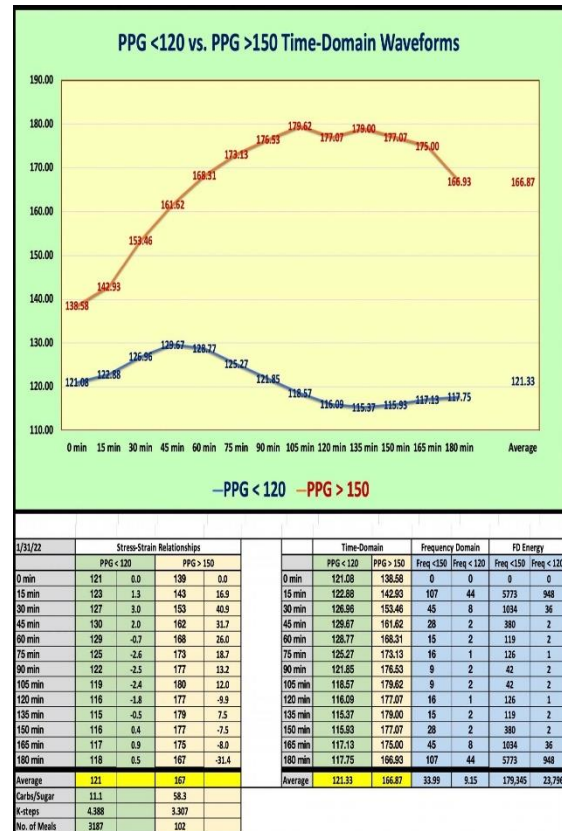

Figure 1: Time-domain PPG and data table of this analysis.

Figure 2 reflects two sets of stress-strain diagrams, i.e. space-domain diagrams. These two sets of stress-strain diagrams look quite different in shape and with a vast difference (26 times) in area size of two hysteresis loops.

The first PPG level of <120 mg/dL of normal condition behaves like an elastic and viscoelastic situation, while the other PPG levels of >150 mg/dL of diabetes condition behave like a plastic and viscoplastic situation.

Figure 3 demonstrates his step-by-step calculation of hysteresis loop areas.

Figure 4 shows the time-domain and frequency-domain results together (upper and middle diagram) with the summary data table of those relative associated energy of PPG (lower diagram).

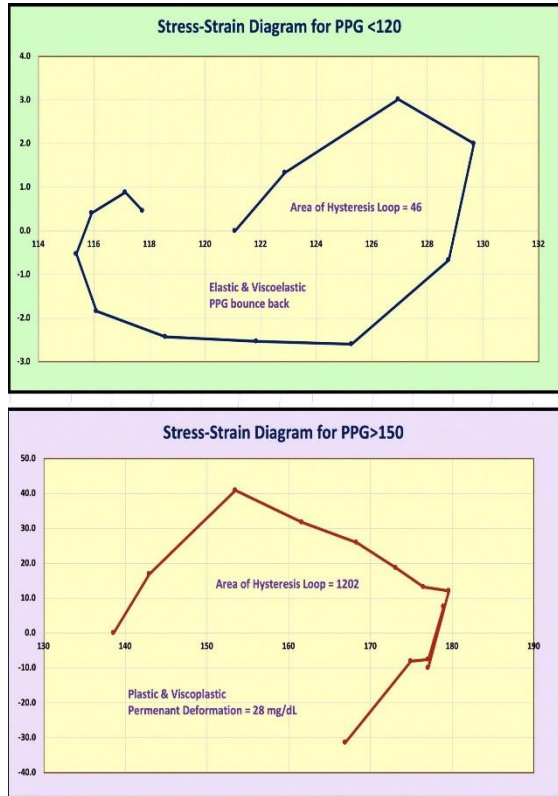

Figure 2: Space-domain of stress-strain diagrams of 2 PPG cases.

PPG < 120	strain <120	stress <120	Base a	Base b	(a+b)/2	h	Area=((a+b)/2)*h
0 min	121	0.0	0.0	1.3	0.7	1.8	1.2
15 min	123	1.3	1.3	3.0	2.2	4.1	8.9
30 min	127	3.0	3.0	2.0	2.5	2.7	6.8
45 min	130	2.0	2.0	-0.7	0.7	-0.9	-0.6
60 min	129	-0.7	-0.7	-2.6	-1.6	-3.5	5.7
75 min	125	-2.6	-2.6	-2.5	-2.6	-3.4	8.8
90 min	122	-2.5	-2.5	-2.4	-2.5	-3.3	8.1
105 min	119	-2.4	-2.4	-1.8	-2.1	-2.5	5.3
120 min	116	-1.8	-1.8	-0.5	-1.2	-0.7	0.9
135 min	115	-0.5	-0.5	0.4	-0.1	0.6	0.0
150 min	116	0.4	0.4	0.9	0.7	1.2	0.8
165 min	117	0.9	0.9	0.5	0.7	0.6	0.4
180 min	118	0.5	0.5	0.0	0.2	-117.8	0.0
Area							46.2

PPG > 150	Post Strain	Post Stress	Base a	Base b	(a+b)/2	h	Area=((a+b)/2)*h
0 min	139	0.0	0.0	16.9	8.5	4.3	36.8
15 min	143	16.9	16.9	40.9	28.9	10.5	304.5
30 min	153	40.9	40.9	31.7	36.3	8.2	296.4
45 min	162	31.7	31.7	26.0	28.9	6.7	193.1
60 min	168	26.0	26.0	18.7	22.4	4.8	107.8
75 min	173	18.7	18.7	13.2	16.0	3.4	54.3
90 min	177	13.2	13.2	12.0	12.6	3.1	39.0
105 min	180	12.0	12.0	-9.9	1.0	-2.6	-2.7
120 min	177	-9.9	-9.9	7.5	-1.2	1.9	-2.3
135 min	179	7.5	7.5	-7.5	0.0	-1.9	0.0
150 min	177	-7.5	-7.5	-8.0	-7.8	-2.1	16.1
165 min	175	-8.0	-8.0	-31.4	-19.7	-8.1	159.0
180 min	167	-31.4	-31.4	0.0	-15.7	-166.9	0.0
Area							1201.9
Area (>150 / <120)							26

Figure 3: Step-by-step calculation table of hysteresis loops.

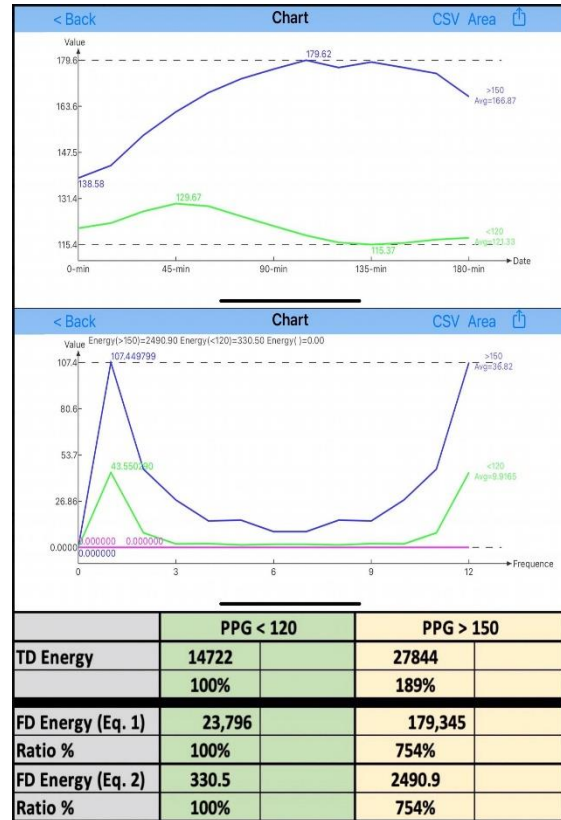

Figure 4: Time-domain and frequency domain with summary data table of relative associated energy of 2 PPG cases.

4. CONCLUSION

In conclusion, the author defines his strain and stress in the following equations:

Strain

$$= \epsilon$$

= individual PPG value

Stress

$$= \sigma$$

$$= \eta * (d\epsilon/dt)$$

$$= \eta * (d\text{-strain}/d\text{-time})$$

= viscosity factor * (PPG at next time instant - PPG at current time instant) / 15

Where 15 indicates the 15-minute timespan of his CGM sensor Glucose measurement.

He then uses 11.1 grams as the viscosity factor for the case of <120, and 58.3 grams as the viscosity factor for the case of >150.

After generating two different hysteresis loops in the stress-strain diagram, he uses the formula of a trapezoid area to calculate the respective hysteresis loop areas which indicate the energy loss during the loading-unloading process on PPG.

By applying the Fast Fourier Transform (FFT) operation, he can transform his PPG from TD into FD. He utilizes the following 3 energy equations to estimate the relative associated energy of PPG:

Time-domain energy equation = summation of square of Y-amplitude in TD i.e., PPG;

Frequency-domain equation 1 = summation of (square of Y-amplitude in FD) / (number of frequency components);

Frequency-domain equation 2 = summation of ((square of Y-amplitude in FD) / 2) then multiplied by (number of frequency components).

Based on the four theories of linear elasticity, plasticity, viscoelasticity, viscoplasticity in Engineering and energy theory in Physics, the following 3 distinct observations are evident:

(1) By observing TD and SD analysis results, the case of <120 mg/dL is elastic and viscoelastic, while the case of >150 mg/dL is plastic and viscoplastic. The viscoelastic or viscoplastic state is a result of their time-dependency characteristic. The difference between elastic and plastic is a result from observing the amount of PPG difference between 0-minute and 90-180 minutes and judging if it has a permanent deformation or not.

(2) The area ratio between <120 case (hysteresis loop area = 46) and >150 case (hysteresis loop area = 1202) is 26. This shows that the energy loss through the viscoplastic >150 case is 26 times higher than the viscoelastic <120 case.

(3) The relative associated energy of PPG has a ratio of 1:1.9 between <120 vs. >150 from

TD energy analysis; however, the relative associated energy of PPG has a ratio of 1:7.5 between <120 vs. >150 from FD energy analysis. This shows that the total energy carried by the hyperglycemic case (>150 mg/dL) is much higher than the normal case (<120 mg/dL); therefore, the hyperglycemia will cause a higher degree of damage to the internal organs.

5. ACKNOWLEDGEMENT

Without Professor Norman Jones at MIT as his academic advisor, the author would not be able to conduct his medical research project and also published 500+ research papers. The author has never forgotten his advice to him that he should always enhance his strength on foundations, such as mathematics and physics, in order to make further improvement and advancement. Professor Jones has also provided him with a personal example of doing outstanding teaching and research jobs with an excellent work attitude, extreme dedication, and ultimate commitment to advancing both science and engineering.

6. REFERENCES

For editing purposes, the majority of the references in this paper, which are self-references, have been removed. Only references from other authors' published sources remain. The bibliography of the author's original self-references can be viewed at www.eclairemd.com.

Readers may use this article as long as the work is properly cited, and their use is educational and not for profit, and the author's original work is not altered.