

The GH-Method

Viscoelastic Glucose Theory (VGT #28) & Nonlinear Plastic Glucose Theory (NPGT #7): Nonlinear Dynamic Plastic and Viscoplastic Glucose Behaviors versus Linear Elastic Glucose Behavior of Postprandial Plasma Glucose (PPG) Waveforms Over a 3.8-Year Period from 5/8/2018 to 2/18/2022 Along with the Plastic PPG Waveforms Impact on the Cardiovascular Disease Risk Probability Based on the GH-Method: Math-Physical Medicine (No. 609)

Gerald C. Hsu*

eclairMD Foundation, USA

Note: Readers who want to get a quick overview can read the abstract, results, and graphs.

Abstract

Recently, the author applied theories of elasticity, plasticity, viscoelasticity, and viscoplasticity from engineering and perturbation theory from quantum mechanics, along with the wave theory and energy theory from physics to conduct his biomedical research on certain output biomarkers, such as glucose (symptoms or behaviors) resulting from a selected input biomarker, such as the carbs/sugar amount, exercise level, or others (causes or stressors). In this article, he chose his synthesized postprandial plasma glucose (PPG) data and waveform over the past 3.8 years as the strain (ϵ or output, symptom). Since 5/8/2018, he has been utilizing a continuous glucose monitoring (CGM) sensor device to collect 96 glucose data each day and 13 glucose data each meal at 15-minute time intervals. In order to investigate and learn the behaviors of the strain (ϵ) or PPG, and its stress (σ) or input/cause as defined to be the estimated average glucose (eAG) change rate multiplied by a selected viscosity factor (η), which is the carbs/sugar intake amount. In this study, he selected "elastic" PPG case with average "Finger-piercing PPG <120 mg/dL along with four "plastic" PPG cases, >120 mg/dL, >140 mg/dL, >180 mg/dL, and >200 mg/dL. The procedure of the analysis contains four steps. Step 1, he draws the 5 PPG (1 elastic and 4 plastic) waveforms in a time-domain (TD) with 15-minutes time interval within a 3-hour time span. Step 2, he calculates the stress values to draw the corresponding stress-strain diagram in a spatial-domain (SD). Step 3, he calculates 4 predicted plastic PPG values using the viscoelastic perturbation model. Step 4, he calculates the corresponding cardiovascular disease (CVD) risk probabilities induced by the 5

cases. There are three main purposes of this research article. First, to verify plastic postprandial plasma glucose (PPG) characteristics via stress-strain diagrams and their comparison against pseudo-linear elastic characteristics. Second, to examine the suitability of viscoperturbation model generated predicted PPG values via both prediction accuracy and correlation coefficient between the predicted PPG and measured PPG. Third, to verify the connectivity between the plastic hyperglycemic situations and heart disease such as CVD risk probabilities. The following two defined equations from the viscoelasticity glucose theory (VGT) are utilized to study the stress-strain relationship for this case study. At first, he selects his PPG as the strain, which is his target research item: Strain = ϵ = individual output biomarker value (PPG) at present time. Furthermore, he wants to use the strain rate or his overall PPG change rate to be multiplied by the selected viscosity factors (carbs/sugar amounts) as the stress: Stress = $\sigma = \eta * (d\epsilon/dt) = \eta * (d\text{-strain}/d\text{-time}) = (\text{viscosity factor } \eta) * ((\text{output biomarker of PPG at present time} - \text{output biomarker of PPG at previous time}); \text{ where his five selected viscosity factors } (\eta) \text{ are: Elastic } <120 \text{ mg/dL: } 11.0 \text{ grams, Plastic } >120 \text{ mg/dL: } 23.5 \text{ grams, Plastic } >140 \text{ mg/dL: } 48.7 \text{ grams, Plastic } >180 \text{ mg/dL: } 85.4 \text{ grams, Plastic } >200 \text{ mg/dL: } 98.6 \text{ grams. To offer a simple explanation to readers who do not have a physics or engineering background, the author includes a brief excerpt from Wikipedia regarding the description of basic concepts for elasticity and plasticity theories, viscoelasticity and viscoplasticity theories from the disciplines of engineering and physics, along$

Received: 13 June 2022, Accepted: 06 July 2022, Available online: 08 July 2022

*Corresponding author: Gerald C. Hsu, eclairMD Foundation, USA

with perturbation theory of quantum mechanics in the method section. In summary, the following six observations outline the key findings: (1) From the 5 PPG waveforms in TD, the glucose value differences for the starting PPG, average PPG, peak PPG, and ending PPG are evident. Special attention should be placed on the glucose difference between ending PPG at 180-minutes and starting PPG at 0-minute. The elastic case has -3 mg/dL difference, while the PPG differences for the 4 plastic cases are 12 mg/dL, 28 mg/dL, 50 mg/dL, and 60 mg/dL, respectively. The same PPG differences can be seen on the stress-strain diagrams of SD. The above observations for the “PPG gaps” differentiate the elastic case versus plastic cases. (2) The PPG value of the elastic <120 mg/dL case around 90-minutes has returned to its original position with the starting PPG value at 0-minute. The subsequent lower PPG values after 90-minutes are a result from the author’s unnecessary and excessive post-meal walking of 4.483 k-steps. In other words, his energy input from carbs/sugar amount of 11 grams would only require about 1.5-2.0 k-steps of post-meal walking to burn it off. Nevertheless, both TD and SD show elastic characteristics. (3) However, for the 4 plastic cases, their carbs/sugar intake amounts of 23.5 grams, 48.7 grams, 85.4 grams, and 98.6 grams, respectively, are excessive and cannot be totally burned off by their corresponding post meal walking of 3.9 k-steps, 3.4 k-steps, 3.6 k-steps, and 3.4 k-steps. This is why there are big “PPG gaps” of 12 mg/dL, 28 mg/dL, 50 mg/dL, 60 mg/dL for the cases of >120 mg/dL, >140 mg/dL, >180 mg/dL, and >200 mg/dL, respectively. These 4 stress-strain diagrams have shown “plastic” or “viscoplastic” behaviors. (4) It is interesting to

discover that the viscoelastic perturbation model is only suitable for cases of elastic <120 mg/dL with a correlation of 96% and plastic >120 mg/dL with a correlation of 75%. The remaining three plastic cases have low correlations below 49%. This observation is the result from the “amplification effect” of higher carbs/sugar grams since the higher viscosity factor (η) would “amplify” the stress values which cause the larger predicted PPG values; therefore, lowering its correlation in comparison with the measured PPG. (5) The respective hysteresis loop area for the 5 cases are 46 (1%) for elastic <120 mg/dL; 169 (3%) for plastic >120 mg/dL; 921 (17%) for plastic >140 mg/dL; 4065 (74%) for plastic >180 mg/dL; 5528 (100%) for plastic >200 mg/dL. (6) The corresponding CVD risk probabilities for the 5 cases are 53.7% for elastic <120 mg/dL; 55.3% for plastic >120 mg/dL; 57.5% for plastic >140 mg/dL; 58.5% for plastic >180 mg/dL; 58.5% for plastic >200 mg/dL. This observation clearly demonstrates the connection between type 2 diabetes (T2D) and heart diseases. In fact, many medical research papers based on statistics state that there are 75% to 80% patients with various heart disease that also have diabetes conditions. The meals with higher carbs/sugar amount would create hyperglycemic (high glucose) situations which will then trigger higher CVD risks. In conclusion, the author has diligently tried to apply his previously learned dynamic plastic structural behavior to his medical research work. Now, after improving his software capability, he is finally able to extract the “suitable hyperglycemic data” from his database in order to conduct this “nonlinear plastic glucose theory (NPGT)” study.

Keywords: Viscoelasticity; Viscoplasticity; Postprandial plasma glucose; Type 2 diabetes; Cardiovascular disease

Abbreviations: PPG: postprandial plasma glucose; CGM: continuous glucose monitoring; eAG: estimated average glucose; VGT: viscoelasticity glucose theory; TD: time-domain; CVD: cardiovascular disease; FPG: fasting plasma glucose; T2D: type 2 diabetes; HbA1C: hemoglobin A1C; MPM: math-physical medicine

1. INTRODUCTION

Recently, the author applied theories of elasticity, plasticity, viscoelasticity, and viscoplasticity from engineering and perturbation theory from quantum mechanics, along with the wave theory and energy theory from physics to conduct his biomedical research on certain output biomarkers, such as glucose (symptoms or behaviors) resulting from a selected input biomarker, such as the carbs/sugar amount, exercise level, or others (causes or stressors).

In this article, he chose his synthesized PPG data and waveform over the past 3.8 years as the strain (ϵ or output, symptom). Since 5/8/2018, he has been utilizing a continuously monitoring glucose sensor (CGM) device to collect 96 glucose data each day and 13 glucose data each meal at 15-minute time intervals. In order to investigate and learn the behaviors of the strain (ϵ) or PPG, and its stress (σ) or input/cause as defined to be the eAG change rate multiplied by a selected viscosity factor (η), which is the carbs/sugar intake amount. In this study, he selected “elastic” PPG case with average “Finger-piercing PPG <120 mg/dL along with four “plastic” PPG cases, >120 mg/dL, >140 mg/dL, >180 mg/dL, and >200 mg/dL.

The procedure of the analysis contains four steps. Step 1, he draws the 5 PPG (1 elastic and 4 plastic) waveforms in a time-domain (TD) with 15-minutes time interval within a 3-hour time span. Step 2, he calculates the stress values to draw the corresponding stress-strain diagram in a spatial-domain (SD). Step 3, he calculates 4 predicted plastic PPG values using the viscoelastic perturbation model. Step 4, he calculates the corresponding cardiovascular disease (CVD) risk probabilities induced by the 5 cases.

There are three main purposes of this research article. First, to verify plastic postprandial plasma glucose (PPG) characteristics via stress-strain diagrams and their comparison against pseudo-linear elastic characteristics. Second, to examine the suitability of visco-perturbation model generated predicted PPG values via both prediction accuracy and correlation coefficient between the predicted PPG and measured PPG. Third, to verify the

connectivity between the plastic hyperglycemic situations and heart disease such as CVD risk probabilities.

The following two defined equations from the viscoelasticity glucose theory (VGT) are utilized to study the stress-strain relationship for this case study.

At first, he selects his PPG as the strain, which is his target research item:

Strain = ϵ
= individual output biomarker value (PPG) at present time

Furthermore, he wants to use the strain rate or his overall PPG change rate to be multiplied by the selected viscosity factors (carbs/sugar amounts) as the stress:

Stress = σ
= $\eta * (d\epsilon/dt)$
= $\eta * (d\text{-strain}/d\text{-time})$
= (viscosity factor η) * ((output biomarker of PPG at present time - output biomarker of PPG at previous time)

Where his five selected viscosity factors (η) are:

Elastic <120 mg/dL: 11.0 grams
Plastic >120 mg/dL: 23.5 grams
Plastic >140 mg/dL: 48.7 grams
Plastic >180 mg/dL: 85.4 grams
Plastic >200 mg/dL: 98.6 grams

To offer a simple explanation to readers who do not have a physics or engineering background, the author includes a brief excerpt from Wikipedia regarding the description of basic concepts for elasticity and plasticity theories, viscoelasticity and viscoplasticity theories from the disciplines of engineering and physics, along with perturbation theory of quantum mechanics in the method section.

2. METHODS

2.1 Brief introduction of math-physical medicine (MPM) research

The author has collected ~3 million data regarding his health condition and lifestyle details over the past 12 years. He spent the entire year of 2014 to develop a metabolism

index (MI) model using topology concept, nonlinear algebra, algebraic geometry, and finite element method. This model contains various measured biomarkers and recorded lifestyle details along with their induced new biomedical variables for an additional ~1.5 million data. Detailed data of his body weight, glucose, blood pressure, heart rate, blood lipids, body temperature, and blood oxygen level, along with important lifestyle details, including diet, exercise, sleep, stress, water intake, and daily life routines are included in the MI data base. His developed MI model has a total of 10 categories covering approximately 500 detailed elements that constitute his defined “metabolism model” which are the building blocks or root causes for diabetes and other chronic disease complications, including but not limited to cardiovascular disease (CVD), chronic heart disease (CHD), stroke, chronic kidney disease (CKD), retinopathy, neuropathy, foot ulcer, and hypothyroidism. The end result of the MI development work is a combined MI value within any selected time period with 73.5% as its dividing line between a healthy and unhealthy state. The MI serves as the foundation to many of his follow-up medical research work.

During the period from 2015 to 2017, he focused his research on type 2 diabetes (T2D), especially glucoses, including FPG, postprandial plasma glucose (PPG), eAG, and hemoglobin A1C (HbA1C). During the following period from 2018 to 2022, he concentrated on researching medical complications resulting from diabetes, chronic diseases, and metabolic disorders which include heart problems, stroke, kidney problems, retinopathy, neuropathy, foot ulcer, diabetic skin fungal infection, hypothyroidism, and diabetic constipation, cancer, and dementia. He also developed a few mathematical risk models to calculate the probability percentages of developing various diabetic complications.

From his previous medical research work, he has identified and learned that those associated energy of hyperglycemia conditions are the primary source of causing many diabetic complications which lead to death. Therefore, a thorough knowledge of these energies is important for achieving a better understanding of those dangerous complications.

2.2 Elasticity, plasticity, viscoelasticity and viscoplasticity

The difference between elastic materials and viscoelastic materials (from “Soborthans, innovating shock and vibration solutions”).

What are elastic materials?

Elasticity is the tendency of solid materials to return to their original shape after forces are applied on them. When the forces are removed, the object will return to its initial shape and size if the material is elastic.

What are viscous materials?

Viscosity is a measure of a fluid’s resistance to flow. A fluid with large viscosity resists motion. A fluid with low viscosity flows. For example, water flows more easily than syrup because it has a lower viscosity. High viscosity materials might include honey, syrups, or gels – generally things that resist flow. Water is a low viscosity material, as it flows readily. Viscous materials are thick or sticky or adhesive. Since heating reduces viscosity, these materials don’t flow easily. For example, warm syrup flows more easily than cold.

What is viscoelastic?

Viscoelasticity is the property of materials that exhibit both viscous and elastic characteristics when undergoing deformation. Synthetic polymers, wood, and human tissue, as well as metals at high temperature, display significant viscoelastic effects. In some applications, even a small viscoelastic response can be significant.

Elastic behavior versus viscoelastic behavior

The difference between elastic materials and viscoelastic materials is that viscoelastic materials have a viscosity factor and the elastic ones don’t. Because viscoelastic materials have the viscosity factor, they have a strain rate dependent on time. Purely elastic materials do not dissipate energy (heat) when a load is applied, then removed; however, a viscoelastic substance does.

The following brief introductions are excerpts from Wikipedia:

“Elasticity (physics):

Physical property when materials or objects return to original shape after deformation.

In physics and materials science, elasticity is the ability of a body to resist a distorting influence and to return to its original size and shape when that influence or force is removed. Solid objects will deform when adequate loads are applied to them; if the material is elastic, the object will return to its initial shape and size after removal. This is in contrast to plasticity, in which the object fails to do so and instead remains in its deformed state.

The physical reasons for elastic behavior can be quite different for different materials. In metals, the atomic lattice changes size and shape when forces are applied (energy is added to the system). When forces are removed, the lattice goes back to the original lower energy state. For rubbers and other polymers, elasticity is caused by the stretching of polymer chains when forces are applied.

Hooke's law states that the force required to deform elastic objects should be directly proportional to the distance of deformation, regardless of how large that distance becomes. This is known as perfect elasticity, in which a given object will return to its original shape no matter how strongly it is deformed. This is an ideal concept only; most materials which possess elasticity in practice remain purely elastic only up to very small deformations, after which plastic (permanent) deformation occurs.

In engineering, the elasticity of a material is quantified by the elastic modulus such as the Young's modulus, bulk modulus or shear modulus which measure the amount of stress needed to achieve a unit of strain; a higher modulus indicates that the material is harder to deform. The material's elastic limit or yield strength is the maximum stress that can arise before the onset of plastic deformation.

Plasticity (physics):

Deformation of a solid material undergoing non-reversible changes of shape in response to applied forces.

In physics and materials science, plasticity, also known as plastic deformation, is the ability of a solid material to undergo permanent deformation, a non-reversible change of shape in response to applied forces. For example, a solid piece of metal being bent or pounded into a new shape displays plasticity as permanent changes occur within the material itself. In engineering, the transition from elastic behavior to plastic behavior is known as yielding.

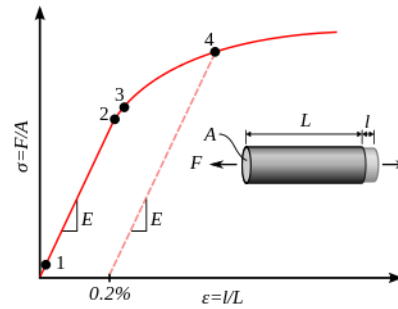

Stress–strain curve showing typical yield behavior for nonferrous alloys.

1. True elastic limit
2. Proportionality limit
3. Elastic limit
4. Offset yield strength

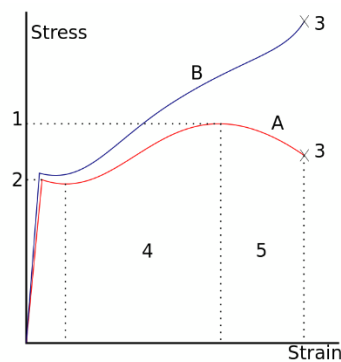

A stress–strain curve typical of structural steel.

- 1: Ultimate strength
- 2: Yield strength (yield point)
- 3: Rupture
- 4: Strain hardening region
- 5: Necking region
- A: Apparent stress (F/A0)
- B: Actual stress (F/A)

Plastic deformation is observed in most materials, particularly metals, soils, rocks, concrete, and foams. However, the physical

mechanisms that cause plastic deformation can vary widely. At a crystalline scale, plasticity in metals is usually a consequence of dislocations. Such defects are relatively rare in most crystalline materials, but are numerous in some and part of their crystal structure; in such cases, plastic crystallinity can result. In brittle materials such as rock, concrete and bone, plasticity is caused predominantly by slip at microcracks. In cellular materials such as liquid foams or biological tissues, plasticity is mainly a consequence of bubble or cell rearrangements, notably T1 processes.

For many ductile metals, tensile loading applied to a sample will cause it to behave in an elastic manner. Each increment of load is accompanied by a proportional increment in extension. When the load is removed, the piece returns to its original size. However, once the load exceeds a threshold – the yield strength – the extension increases more rapidly than in the elastic region; now when the load is removed, some degree of extension will remain.

Elastic deformation, however, is an approximation and its quality depends on the time frame considered and loading speed. If, as indicated in the graph opposite, the deformation includes elastic deformation, it is also often referred to as "elasto-plastic deformation" or "elastic-plastic deformation".

Perfect plasticity is a property of materials to undergo irreversible deformation without any increase in stresses or loads. Plastic materials that have been hardened by prior deformation, such as cold forming, may need increasingly higher stresses to deform further. Generally, plastic deformation is also dependent on the deformation speed, i.e. higher stresses usually have to be applied to increase the rate of deformation. Such materials are said to deform viscoplastically.”

Viscoelasticity:

Property of materials with both viscous and elastic characteristics under deformation.

In materials science and continuum mechanics, viscoelasticity is the property of materials that exhibit both viscous and elastic characteristics when undergoing deformation. Viscous materials, like water,

resist shear flow and strain linearly with time when a stress is applied. Elastic materials strain when stretched and immediately return to their original state once the stress is removed.

Viscoelastic materials have elements of both of these properties and, as such, exhibit time-dependent strain. Whereas elasticity is usually the result of bond stretching along crystallographic planes in an ordered solid, viscosity is the result of the diffusion of atoms or molecules inside an amorphous material.

In the nineteenth century, physicists such as Maxwell, Boltzmann, and Kelvin researched and experimented with creep and recovery of glasses, metals, and rubbers. Viscoelasticity was further examined in the late twentieth century when synthetic polymers were engineered and used in a variety of applications. Viscoelasticity calculations depend heavily on the viscosity variable, η . The inverse of η is also known as fluidity, ϕ . The value of either can be derived as a function of temperature or as a given value (i.e. for a dashpot).

Depending on the change of strain rate versus stress inside a material, the viscosity can be categorized as having a linear, non-linear, or plastic response. When a material exhibits a linear response it is categorized as a Newtonian material. In this case the stress is linearly proportional to the strain rate. If the material exhibits a non-linear response to the strain rate, it is categorized as Non-Newtonian fluid. There is also an interesting case where the viscosity decreases as the shear/strain rate remains constant. A material which exhibits this type of behavior is known as thixotropic. In addition, when the stress is independent of this strain rate, the material exhibits plastic deformation. Many viscoelastic materials exhibit rubber like behavior explained by the thermodynamic theory of polymer elasticity.

Cracking occurs when the strain is applied quickly and outside of the elastic limit. Ligaments and tendons are viscoelastic, so the extent of the potential damage to them depends both on the rate of the change of their length as well as on the force applied.

A viscoelastic material has the following properties:

- hysteresis is seen in the stress–strain curve
- stress relaxation occurs: step constant strain causes decreasing stress
- creep occurs: step constant stress causes increasing strain
- its stiffness depends on the strain rate or the stress rate.

Elastic versus viscoelastic behavior

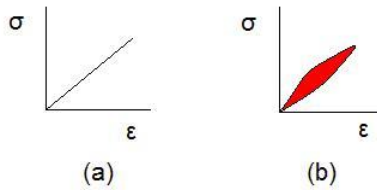

Stress–strain curves for a purely elastic material (a) and a viscoelastic material (b). The red area is a hysteresis loop and shows the amount of energy lost (as heat) in a loading and unloading cycle. It is equal to

$$\oint \sigma d\epsilon$$

where σ is stress and ϵ is strain.

Unlike purely elastic substances, a viscoelastic substance has an elastic component and a viscous component. The viscosity of a viscoelastic substance gives the substance a strain rate dependence on time. Purely elastic materials do not dissipate energy (heat) when a load is applied, then removed. However, a viscoelastic substance dissipates energy when a load is applied, then removed. Hysteresis is observed in the stress–strain curve, with the area of the loop being equal to the energy lost during the loading cycle. Since viscosity is the resistance to thermally activated plastic deformation, a viscous material will lose energy through a loading cycle. Plastic deformation results in lost energy, which is uncharacteristic of a purely elastic material's reaction to a loading cycle.

Specifically, viscoelasticity is a molecular rearrangement. When a stress is applied to a viscoelastic material such as a polymer, parts of the long polymer chain change positions. This movement or rearrangement is called “creep”. Polymers remain a solid material even when these parts of their chains are rearranging in order to accompany the stress, and as this occurs, it creates a back stress in

the material. When the back stress is the same magnitude as the applied stress, the material no longer creeps. When the original stress is taken away, the accumulated back stresses will cause the polymer to return to its original form. The material creeps, which gives the prefix visco-, and the material fully recovers, which gives the suffix -elasticity.

Viscoplasticity:

Viscoplasticity is a theory in continuum mechanics that describes the rate-dependent inelastic behavior of solids. Rate-dependence in this context means that the deformation of the material depends on the rate at which loads are applied. The inelastic behavior that is the subject of viscoplasticity is plastic deformation which means that the material undergoes unrecoverable deformations when a load level is reached. Rate-dependent plasticity is important for transient plasticity calculations. The main difference between rate-independent plastic and viscoplastic material models is that the latter exhibit not only permanent deformations after the application of loads but continue to undergo a creep flow as a function of time under the influence of the applied load.

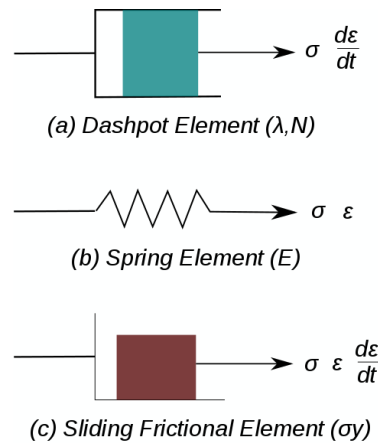

Figure 1. Elements used in one-dimensional models of viscoplastic materials.

The elastic response of viscoplastic materials can be represented in one-dimension by Hookean spring elements. Rate-dependence can be represented by nonlinear dashpot elements in a manner similar to viscoelasticity. Plasticity can be accounted for by adding sliding frictional elements as shown in Figure 1. In the figure E is the modulus of elasticity, λ is the viscosity parameter and N is a power-law type

parameter that represents non-linear dashpot [$\sigma(d\varepsilon/dt) = \sigma = \lambda(d\varepsilon/dt)(1/N)$]. The sliding element can have a yield stress (σ_y) that is strain rate dependent, or even constant, as shown in Figure 1c.

Viscoplasticity is usually modeled in three-dimensions using overstress models of the Perzyna or Duvaut-Lions types. In these models, the stress is allowed to increase beyond the rate-independent yield surface upon application of a load and then allowed to relax back to the yield surface over time. The yield surface is usually assumed not to be rate-dependent in such models. An alternative approach is to add a strain rate dependence to the yield stress and use the techniques of rate independent plasticity to calculate the response of a material.

For metals and alloys, viscoplasticity is the macroscopic behavior caused by a mechanism linked to the movement of dislocations in grains, with superposed effects of inter-crystalline gliding. The mechanism usually becomes dominant at temperatures greater than approximately one third of the absolute melting temperature. However, certain alloys exhibit viscoplasticity at room temperature (300K). For polymers, wood, and bitumen, the theory of viscoplasticity is required to describe behavior beyond the limit of elasticity or viscoelasticity.

In general, viscoplasticity theories are useful in areas such as

- the calculation of permanent deformations,
- the prediction of the plastic collapse of structures,
- the investigation of stability,
- crash simulations,
- systems exposed to high temperatures such as turbines in engines, e.g. a power plant,
- dynamic problems and systems exposed to high strain rates.

Phenomenology

For a qualitative analysis, several characteristic tests are performed to describe the phenomenology of viscoplastic materials. Some examples of these tests are

1. hardening tests at constant stress or strain rate,
2. creep tests at constant force, and
3. stress relaxation at constant elongation.

Strain hardening test

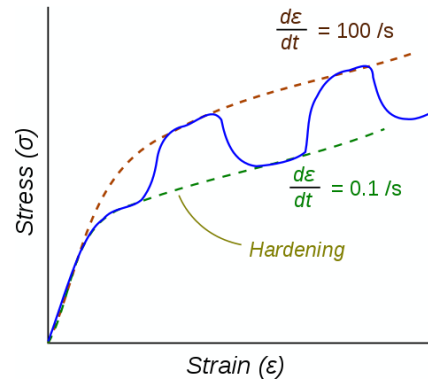

Figure 2. Stress–strain response of a viscoplastic material at different strain rates.

The dotted lines show the response if the strain-rate is held constant. The blue line shows the response when the strain rate is changed suddenly.

One consequence of yielding is that as plastic deformation proceeds, an increase in stress is required to produce additional strain. This phenomenon is known as Strain/Work hardening. For a viscoplastic material the hardening curves are not significantly different from those of rate-independent plastic material. Nevertheless, three essential differences can be observed.

1. At the same strain, the higher the rate of strain the higher the stress
2. A change in the rate of strain during the test results in an immediate change in the stress–strain curve.
3. The concept of a plastic yield limit is no longer strictly applicable.

The hypothesis of partitioning the strains by decoupling the elastic and plastic parts is still applicable where the strains are small, i.e.,

$$\varepsilon = \varepsilon_e + \varepsilon_{vp}$$

where ε_e is the elastic strain and ε_{vp} is the viscoplastic strain.

To obtain the stress–strain behavior shown in blue in the figure, the material is initially

loaded at a strain rate of 0.1/s. The strain rate is then instantaneously raised to 100/s and held constant at that value for some time. At the end of that time period the strain rate is dropped instantaneously back to 0.1/s and the cycle is continued for increasing values of strain. There is clearly a lag between the strain-rate change and the stress response. This lag is modeled quite accurately by overstress models (such as the Perzyna model) but not by models of rate-independent plasticity that have a rate-dependent yield stress.

Perturbation theory:

This article is about perturbation theory as a general mathematical method. In mathematics and applied mathematics, perturbation theory comprises methods for finding an approximate solution to a problem, by starting from the exact solution of a related, simpler problem. A critical feature of the technique is a middle step that breaks the problem into "solvable" and "perturbative" parts. In perturbation theory, the solution is expressed as a power series in a small parameter ϵ . The first term is the known solution to the solvable problem. Successive terms in the series at higher powers of ϵ usually become smaller. An approximate 'perturbation solution' is obtained by truncating the series, usually by keeping only the first two terms, the solution to the known problem and the 'first order' perturbation correction."

Note: For a more detailed description, please refer to the "consolidated method" section which is given at the beginning of the special issue.

3. RESULTS

Figure 1 displays two data tables of the input data and calculation details (upper table) along with the summarized results table (lower table).

Figure 2 shows 5 PPG waveforms in TD.

Figure 3 illustrates the elastic <120 mg/dL case in both TD (upper diagram) and viscoelastic stress-strain diagram in SD (lower diagram).

Figure 4 reflects the plastic cases in 4 viscoplastic stress-strain diagrams which use 4 different viscosity factors (carbs/sugar amounts), $\eta = 23.5g, 49.7g, 85.4g,$ and $98.6g$.

Figure 5 depicts a bar chart with 5 CVD risk probability % for 5 cases respectively.

1/2/3/2	carbs				carbs				carbs				carbs				carbs			
Viscosity Factor	23.5				49.7				85.4				98.6				23.5			
PPG	<120	Stress<120	Prod.<120	>120	Stress>120	Prod.>120	>140	Stress>140	Prod.>140	>180	Stress>180	Prod.>180	>200	Stress>200	Prod.>200	>230	Stress>230	Prod.>230		
7min	121	8.0	121	129	8.0	129	153	8.0	153	140	8.0	140	142	8.0	142	142	8.0	142	142	
15min	123	1.7	124	133	6.5	140	140	2.3	152	64.1	2.6	157	86.0	2.9	157	86.0	2.9	157	86.0	
30min	127	3.0	131	140	10.6	151	140	29.4	178	163	64.1	227	172	86.5	271	172	86.5	271	172	
45min	129	2.0	131	140	9.5	155	158	28.7	186	177	80.6	238	185	86.7	271	185	86.7	271	185	
60min	129	-6.6	138	149	6.4	155	163	18.4	182	187	54.8	241	183	86.8	244	183	86.8	244	183	
75min	125	-2.6	133	148	-6.6	148	167	11.6	179	192	38.0	222	196	22.3	229	196	22.3	229	196	
90min	122	-2.5	129	148	-1.1	147	171	11.9	183	201	54.1	235	208	76.3	244	208	76.3	244	208	
105min	118	-2.4	126	147	-2.1	145	172	3.5	175	200	21.1	236	208	1.6	239	208	1.6	239	208	
120min	116	-3.8	124	146	-2.1	144	174	5.8	180	207	36.6	238	211	21.1	232	211	21.1	232	211	
135min	115	-4.5	125	144	-2.3	142	172	-3.9	180	202	-26.8	176	211	-3.0	208	211	-3.0	208	211	
150min	118	0.5	126	143	-1.8	141	170	-4.2	182	205	15.2	220	217	48.1	241	217	48.1	241	217	
165min	117	0.9	128	142	-6.3	148	169	-2.6	186	201	-20.4	181	213	-27.3	186	213	-27.3	186	213	
180min	118	0.5	128	141	-3.3	137	162	-34.0	188	190	-40.2	127	202	-74.1	129	202	-74.1	129	202	
Average	121	-4.2	121	140	1.4	144	161	7.1	189	186	23.9	208	194	76.3	214	194	76.3	214	194	
Accuracy	100%				98%				99%				88%				89%			
Correlation	96%				75%				48%				21%				15%			

Summary:	Mean No.	Carbs grams	Ksteps	180min-Dmin	Avg. PPG	Peak PPG	Peak %	CVD Risk %	Prod. Accuracy	Correlation	Loop Area	Loop Area %
Elastic <120	3226	11.0	4.387	-3	121	110	2.57%	53.72%	100%	96%	46	1%
Plastic >120	966	23.5	3.903	12	143	130	2.89%	55.25%	99%	75%	169	3%
Plastic >140	154	48.7	3.400	28	161	150	2.18%	57.51%	96%	49%	921	17%
Plastic >180	24	85.4	3.580	50	186	175	2.89%	58.46%	88%	21%	4065	74%
Plastic >200	13	98.6	3.358	60	194	185	3.43%	58.50%	84%	11%	5528	100%

Figure 1: Data tables of both input data and calculation details (upper table) and the summarized results table (lower table).

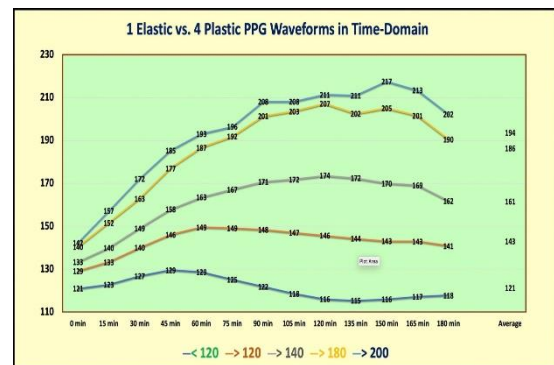

Figure 2: 5 PPG waveforms in a time-domain (TD).

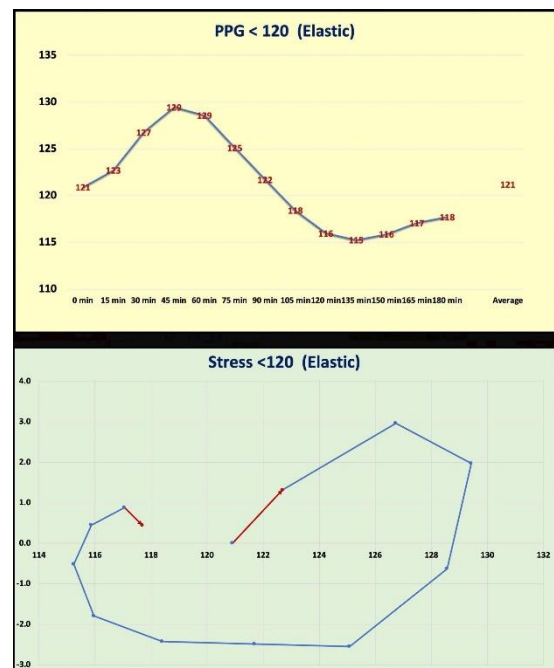

Figure 3: Elastic <120 mg/dL case in both TD (upper diagram) and SD, viscoelastic stress-strain diagram, (lower diagram).

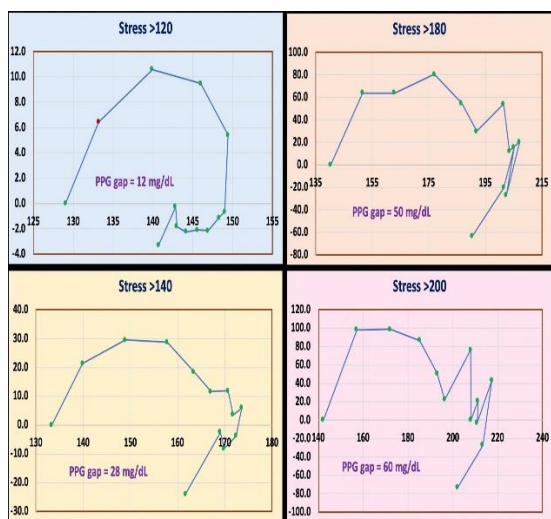

Figure 4: 4 plastic cases in 4 viscoplastic stress-strain diagrams which use 4 different viscosity factors (i.e., carbs/sugar amounts), η = 23.5g, 49.7g, 85.4g, and 98.6g.

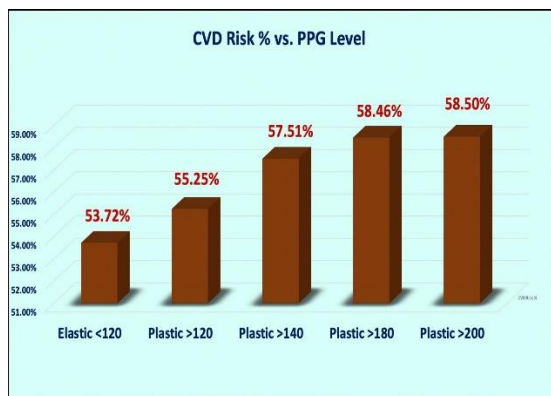

Figure 5: A bar chart with 5 CVD risk probability % for 5 cases respectively.

4. CONCLUSION

In summary, the following six observations outline the key findings:

(1) From the 5 PPG waveforms in TD, the glucose value differences for the starting PPG, average PPG, peak PPG, and ending PPG are evident. Special attention should be placed on the glucose difference between ending PPG at 180-minutes and starting PPG at 0-minute. The elastic case has -3 mg/dL difference, while the PPG differences for the 4 plastic cases are 12 mg/dL, 28 mg/dL, 50 mg/dL, and 60 mg/dL, respectively. The same PPG differences can be seen on the stress-strain diagrams of SD. The above observations for the “PPG gaps” differentiate the elastic case versus plastic cases.

(2) The PPG value of the elastic <120 mg/dL case around 90-minutes has returned to its original position with the starting PPG value at 0-minute. The subsequent lower PPG

values after 90-minutes are a result from the author’s unnecessary and excessive post-meal walking of 4.483 k-steps. In other words, his energy input from carbs/sugar amount of 11 grams would only require about 1.5-2.0 k-steps of post-meal walking to burn it off. Nevertheless, both TD and SD show elastic characteristics.

(3) However, for the 4 plastic cases, their carbs/sugar intake amounts of 23.5 grams, 48.7 grams, 85.4 grams, and 98.6 grams, respectively, are excessive and cannot be totally burned off by their corresponding post meal walking of 3.9 k-steps, 3.4 k-steps, 3.6 k-steps, and 3.4 k-steps. This is why there are big “PPG gaps” of 12 mg/dL, 28 mg/dL, 50 mg/dL, 60 mg/dL for the cases of >120 mg/dL, >140 mg/dL, >180 mg/dL, and >200 mg/dL, respectively. These 4 stress-strain diagrams have shown “plastic” or “viscoplastic” behaviors.

(4) It is interesting to discover that the viscoelastic perturbation model is only suitable for cases of elastic <120 mg/dL with a correlation of 96% and plastic >120 mg/dL with a correlation of 75%. The remaining three plastic cases have low correlations below 49%. This observation is the result from the “amplification effect” of higher carbs/sugar grams since the higher viscosity factor (η) would “amplify” the stress values which cause the larger predicted PPG values; therefore, lowering its correlation in comparison with the measured PPG.

(5) The respective hysteresis loop area for the 5 cases are 46 (1%) for elastic <120 mg/dL; 169 (3%) for plastic >120 mg/dL; 921 (17%) for plastic >140 mg/dL; 4065 (74%) for plastic >180 mg/dL; 5528 (100%) for plastic >200 mg/dL.

(6) The corresponding CVD risk probabilities for the 5 cases are 53.7% for elastic <120 mg/dL; 55.3% for plastic >120 mg/dL; 57.5% for plastic >140 mg/dL; 58.5% for plastic >180 mg/dL; 58.5% for plastic >200 mg/dL. This observation clearly demonstrates the connection between type 2 diabetes (T2D) and heart diseases. In fact, many medical research papers based on statistics state that there are 75% to 80% patients with various heart disease that also have diabetes conditions. The meals with higher carbs/sugar amount would create

hyperglycemic (high glucose) situations which will then trigger higher CVD risks.

In conclusion, the author has diligently tried to apply his previously learned dynamic plastic structural behavior to his medical research work. Now, after improving his software capability, he is finally able to extract the “suitable hyperglycemic data” from his database in order to conduct this “nonlinear plastic glucose theory (NPGT)” study.

5. REFERENCES

For editing purposes, the majority of the references in this paper, which are self-references, have been removed. Only references from other authors' published sources remain. The bibliography of the author's original self-references can be viewed at www.eclairemd.com.

Readers may use this article as long as the work is properly cited, and their use is educational and not for profit, and the author's original work is not altered.

Viscoelastic and Viscoplastic Glucose Theory Application in Medicine

Gerald C. Hsu

