

The GH-Method

Viscoelastic and Viscoplastic Glucose Theory (VGT #31): Applying VGT with Two Different CGM Sensor Measured 2-Hour Postprandial Plasma Glucose (PPG) Values from 240 Liquid Egg Meals and 191 Solid Egg Meals as the Strain, Along with the PPG Change Rate Multiplied by a Viscosity Factor of Average Carbs/Sugar Amounts for Each Egg Meal Type as the Stress, and then Applying the Viscoelastic Perturbation Model to Calculate Two Predicted PPG Values to Compare Against Two Measured PPG Values Based on GH-Method: Math-Physical Medicine (No. 612)

Gerald C. Hsu*

eclairMD Foundation, USA

Note: Readers who want to get a quick overview can read the abstract, results, and graphs.

Abstract

The author has studied strength of materials and theory of elasticity through his undergraduate courses at the University of Iowa. He also conducted research work and earned a master's degree in Biomechanics under Professor James Andrews. In 1970-1971, he used a combined spring and dashpot model to simulate the behaviors of human joints, bones, muscles, and tendons in order to investigate the human-weapon interactions during the Vietnam war era. Later, he went to MIT to pursue his PhD study under Professor Norman Jones, who taught him theory of plasticity and dynamic plastic behaviors of various structure elements. To further his education, he took additional graduate courses in various fields of fluid dynamics, thermodynamics, bridge design using energy absorption pad, and soil mechanics under earthquake influences which have dealt with "time-dependency" issues. Since then, many advancements have been made in the biomechanics branch, especially with human body live tissues that possess certain viscoelastic characteristics, such as bones, muscles, cartilages, tendons (connect bone to muscle), ligaments (connect bone to bone), fascia, and skin. For example, the author suffered plantar fasciitis for many years. He understood that the night splint dorsiflexes forefoot, at the back of the foot, increases plantar fascia tension to offer stress-relief for the pain. This model where muscles and tendons connect the lower leg and foot is a form of viscoelastic study for medical problem solving.

When dealing with human internal organs, it is not easy to conduct live experiments to obtain accurate measurements for the biomedical material properties. Blood itself is a viscous material (time-dependent) and its viscosity factor may fall between water, honey, syrup, or gel. But, the author's research focus is on "glucose" where the blood sugar amount is produced by the liver and carried by red blood cells, not the blood itself. The postprandial plasma glucose (PPG) is strongly influenced by both energy input via carbs/sugar intake amount (~60%) and energy output via post-meal exercise level (~40%). Fundamentally, the PPG level is also dependent on the individual's health conditions in regard to liver cells and pancreatic beta cells, which produce glucose and release insulin to control the glucose level in blood. Therefore, it is nearly impossible to measure the material geometry or material properties to determine the viscosity of "glucose" like in engineering research work. As a result, the best the author could do is to apply the "concept" of viscoelasticity and/or viscoplasticity" to construct an analogy model of time-dependent glucose behaviors. The author's background includes mathematics, physics, and various engineering disciplines, not including biology and chemistry. He can only investigate the observed biophysical phenomena in the medical field using his ready-learned math-physical tools. For example, he studied both modern physics and quantum mechanics during his school days; therefore, he applied the theory of relativity on interactions

Received: 13 June 2022, Accepted: 08 July 2022, Available online: 11 July 2022

*Corresponding author: Gerald C. Hsu, eclairMD Foundation, USA

among the organs in the human body (inner space) which is similar to the inter-relationships among the planets in the universe (outer space). This analogy of using the theory of relativity has been applied to in medicine to prove the inter-connectivity of internal organs. By utilizing the perturbation theory, he was able to obtain an approximate but accurate predicted glucose level along with the estimation for the associated energy of glucose. In addition, he conducted some investigations on glucose behaviors using elasticity theory and plasticity theory (both static and dynamic), which allowed him to write a few articles on his research findings. Recently, the author has received an email from Professor Norman Jones, his academic advisor at MIT. Professor Jones wrote that: "I have wondered if the use of viscoelastic/viscoplastic materials might be of some value to your studies. These phenomena embrace time-dependent behaviour and I know that you have emphasized the time-dependence of various behaviours in the body. Just a thought." His suggestion has triggered the author's strong interest and desire to research this subject of glucose behaviors further by using the viscosity theory. Nevertheless, the medical field is still quite different from the engineering field, where the engineering materials such as steel, copper, concrete, and aluminum are inorganic in most cases. These material properties do not change significantly over their expected lifespans. However, in medicine, the human body with its internal organs and cells are organic and go through many distinct stages over their natural lifespans, such as birth, splitting, growth, mutation, development, repair, sickness, and death. Therefore, the biomedical properties are "moving targets" which vary with the individual person, severity of diseases, and selected different time-windows. In other words, they are both time-dependent and specimen-dependent. Furthermore, some basic material characteristics, such as calculations for the cross-section of a subject, bending moment of resistance, or the shape factors in solid mechanics, are not applicable in this biomedical glucose analogy study of elasticity/plasticity or viscoelasticity/viscoplasticity. In the author's opinion, the most important part is that by applying the concept of elasticity/plasticity theory or viscoelasticity/viscoplasticity theory on understanding or illustrating the observed biomedical phenomena is extremely useful to explore deep insights or enable the prediction of glucoses, particularly for both hyperglycemic conditions (leading into various internal organ complications) and hypoglycemic conditions (insulin shock leading to possible sudden death). In this particular viscoelasticity study, he utilized a continuous glucose monitoring (CGM) device to collect his PPG values at each 15-minute time intervals during the 2 hours of PPG effective time span which is different from most of his studies thus far using the 3-hour time span, as shown in

his paper No. 611. In his previous published papers, the author has already explained one scenario in which the stomach sends messages to the brain regarding food arrival and food contents, either liquid or solid. Our brain then makes decisions and informs both the liver and pancreas via the nervous system to produce or release glucose and insulin. After observing his noticeable PPG differences between egg soups versus pan-fried or hard-boiled eggs, he has learned how to "trick" his brain to achieve his goal of lowering his PPG levels by consuming liquified meals. For diabetes control in clinical practice, most doctors advise their patients to measure their PPG at 2 hours after their first bite of meals. In the diabetes research field, there is no clear definition of a standard time duration of a PPG waveform. In the author's research, he selected a 3-hour duration to cover a wider time span. However, at times, he consumed certain fruits between 120-minutes and 180-minutes which would alter his PPG waveform. A standard PPG waveform looks like a "hill" which rises from 0-minute to 60-minutes due to the carbs/sugar intake (energy infusion), and drops from 60-minutes to 120-minutes due to post-meal exercise (energy consumption). After 120-minutes, the PPG moving direction of either upward or downward depends on the additional carbs/sugar intake and continuation of exercise activities. In this study, he has chosen to remove his collected PPG data and waveform after 120-minutes and conduct the time-domain (TD) analysis, spatial domain (SD) stress-strain analysis, along with the prediction of PPG by applying the viscoelastic perturbation model. Here, he uses PPG as the strain and the carbs/sugar intake amount as the influential factor or viscosity factor. In order to include time-dependent characteristics, he uses the PPG change rate multiplied by a viscosity factor (4.1 grams for 240 liquid egg meals and 3.5 grams for 191 solid egg meals) in his stress-strain analysis and viscoelastic perturbation analysis. To offer a simple explanation to readers who do not have a physics or engineering background, the author includes a brief excerpt from Wikipedia regarding the description of basic concepts for elasticity, plasticity, viscoelasticity, viscoplasticity, and perturbation theories from the disciplines of engineering and physics in the method section. In conclusion, the author has defined his stress-strain equations as follows: Strain = ϵ = (sensor PPG value) at each time interval. Viscosity factor = η = (average carbs/sugar intake grams) of each type of egg meals. However, he has utilized the PPG change rate multiplied with the above-described viscosity factor to obtain the stress: Stress = $\eta * (d\epsilon/dt) = \eta * (d\text{-strain}/d\text{-time}) = ((\text{viscosity factor of present month}) * (\text{PPG of present time interval} - \text{PPG of previous time interval}) / 15)$; where 15 indicates the 15-minute time intervals of his collected PPG data. Based on stress-strain analysis in both TD and SD by applying theory of viscoelasticity or viscoplasticity, and viscoelastic perturbation

model, the following 3 distinct observations are evident: (1) In the TD display of PPG waveforms, the PPG waveform of 191 solid egg meals has higher values of average PPG, initial PPG, peak PPG, and ending PPG, than the PPG waveforms of 240 liquid egg meals. This observed biophysical phenomenon can be interpreted using the brain neuro-scientific explanation. Interestingly, the correlation of the two PPG waveforms within the 2-hour time span is +83% which indicates high correlation (for the 3-hour PPG time span, the correlation is -23% due to the PPG segment between 120-minutes and 180-minutes). (2) Observing the two stress-strain diagrams in SD, the measured PPG using carbs/sugar grams as the viscosity factor have shown two similar hysteresis loops but still somewhat different looks in their curve shapes. For the 240 liquid egg meals, the viscoplastic stress-strain curve has 4 mg/dL strain gap (i.e., PPG difference) between the initial PPG at 0-minute and the ending PPG at 120-minutes. Whereas the 191 solid egg meals, the viscoelastic stress-strain curve looks more like a “standard”

hysteresis loop generated from his overall PPG curve with viscoelastic behavior (starting PPG at 0-minute and PPG at 120-minutes are remarkably close to each other) which has only 1 mg/dL strain gap. Interestingly, it has also demonstrated both the stress-creeping phenomenon (upper portion) and the strain-relaxation phenomenon (right portion). (3) The predicted PPG values using viscoelastic perturbation method have achieved extremely high prediction accuracy of 100% for both 240 liquid egg meals and 191 solid egg meals. Their correlation coefficients are 99% for both 240 liquid egg meals and 191 solid egg meals. This indicates that the predicted PPG values using a viscoelastic perturbation model have reached high prediction accuracy and high waveform similarity. In summary, while researching brain neuroscience, the author also utilized an average carbs/sugar intake amount as the viscosity factor and applied the viscoelastic perturbation model to analyze the 2-hour PPG data and waveform. As a result, he could produce a highly satisfactory prediction for PPG.

Keywords: Viscoelastic; Viscoplastic; Postprandial plasma glucose; Strain; Stress; Viscosity factor; Type 2 diabetes

Abbreviations: PPG: postprandial plasma glucose; FPG: fasting plasma glucose; CGM: continuous glucose monitoring; TD: time-domain; SD: spatial-domain; MPM: math-physical medicine

1. INTRODUCTION

The author has studied strength of materials and theory of elasticity through his undergraduate courses at the University of Iowa. He also conducted research work and earned a master's degree in Biomechanics under Professor James Andrews. In 1970-1971, he used a combined spring and dashpot model to simulate the behaviors of human joints, bones, muscles, and tendons in order to investigate the human-weapon interactions during the Vietnam war era. Later, he went to MIT to pursue his PhD study under Professor Norman Jones, who taught him theory of plasticity and dynamic plastic behaviors of various structure elements. To further his education, he took additional graduate courses in various fields of fluid dynamics, thermodynamics, bridge design using energy absorption pad, and soil mechanics under earthquake influences which have dealt with "time-dependency" issues.

Since then, many advancements have been made in the biomechanics branch, especially with human body live tissues that possess certain viscoelastic characteristics, such as bones, muscles, cartilages, tendons (connect bone to muscle), ligaments (connect bone to bone), fascia, and skin. For example, the author suffered plantar fasciitis for many years. He understood that the night splint dorsiflexes forefoot, at the back of the foot, increases plantar fascia tension to offer stress-relief for the pain. This model where muscles and tendons connect the lower leg and foot is a form of viscoelastic study for medical problem solving.

When dealing with human internal organs, it is not easy to conduct live experiments to obtain accurate measurements for the biomedical material properties. Blood itself is a viscous material (time-dependent) and its viscosity factor may fall between water, honey, syrup, or gel. But, the author's research focus is on "glucose" where the blood sugar amount is produced by the liver and carried by red blood cells, not the blood itself. The postprandial plasma glucose (PPG) is strongly influenced by both energy input via carbs/sugar intake amount (~60%) and energy output via post-meal exercise level (~40%). Fundamentally, the PPG level is also

dependent on the individual's health conditions in regard to liver cells and pancreatic beta cells, which produce glucose and release insulin to control the glucose level in blood. Therefore, it is nearly impossible to measure the material geometry or material properties to determine the viscosity of "glucose" like in engineering research work. As a result, the best the author could do is to apply the "concept" of viscoelasticity and/or viscoplasticity" to construct an analogy model of time-dependent glucose behaviors.

The author's background includes mathematics, physics, and various engineering disciplines, not including biology and chemistry. He can only investigate the observed biophysical phenomena in the medical field using his ready-learned math-physical tools. For example, he studied both modern physics and quantum mechanics during his school days; therefore, he applied the theory of relativity on interactions among the organs in the human body (inner space) which is similar to the inter-relationships among the planets in the universe (outer space). This analogy of using the theory of relativity has been applied to in medicine to prove the inter-connectivity of internal organs.

By utilizing the perturbation theory, he was able to obtain an approximate but accurate predicted glucose level along with the estimation for the associated energy of glucose. In addition, he conducted some investigations on glucose behaviors using elasticity theory and plasticity theory (both static and dynamic), which allowed him to write a few articles on his research findings.

Recently, the author has received an email from Professor Norman Jones, his academic advisor at MIT. Professor Jones wrote that: "I have wondered if the use of viscoelastic/viscoplastic materials might be of some value to your studies. These phenomena embrace time-dependent behaviour and I know that you have emphasized the time-dependence of various behaviours in the body. Just a thought." His suggestion has triggered the author's strong interest and desire to research this subject of glucose behaviors further by using the viscosity theory.

Nevertheless, the medical field is still quite different from the engineering field, where the engineering materials such as steel, copper, concrete, and aluminum are inorganic in most cases. These material properties do not change significantly over their expected lifespans. However, in medicine, the human body with its internal organs and cells are organic and go through many distinct stages over their natural lifespans, such as birth, splitting, growth, mutation, development, repair, sickness, and death. Therefore, the biomedical properties are “moving targets” which vary with the individual person, severity of diseases, and selected different time-windows. In other words, they are both time-dependent and specimen-dependent. Furthermore, some basic material characteristics, such as calculations for the cross-section of a subject, bending moment of resistance, or the shape factors in solid mechanics, are not applicable in this biomedical glucose analogy study of elasticity/plasticity or viscoelasticity/viscoplasticity. In the author’s opinion, the most important part is that by applying the concept of elasticity/plasticity theory or viscoelasticity/viscoplasticity theory on understanding or illustrating the observed biomedical phenomena is extremely useful to explore deep insights or enable the prediction of glucoses, particularly for both hyperglycemic conditions (leading into various internal organ complications) and hypoglycemic conditions (insulin shock leading to possible sudden death).

In this particular viscoelasticity study, he utilized a continuous glucose monitoring (CGM) device to collect his PPG values at 15-minute time intervals during the 2 hours of PPG effective time span. This is different from most of his studies to date using the 3-hour time span, as shown in paper No. 611.

In his published papers, the author has explained that the stomach sends messages to the brain regarding food arrival and food contents, either liquid or solid. Our brain then makes decisions and informs both the liver and pancreas via the nervous system to produce or release glucose and insulin. After observing his noticeable PPG differences between egg soups versus pan-fried or hard-boiled eggs, he has learned how to “trick” his brain to achieve his goal of lowering his PPG levels by consuming liquified meals.

For diabetes control in clinical practice, most doctors advise their patients to measure their PPG at 2 hours after their first bite of meals. In the diabetes research field, there is no clear definition of a standard time duration of a PPG waveform. In the author’s research, he selected a 3-hour duration to cover a wider time span. However, at times, he consumed certain fruits between 120-minutes and 180-minutes which would alter his PPG waveform. A standard PPG waveform looks like a “hill” which rises from 0-minute to 60-minutes due to the carbs/sugar intake (energy infusion), and drops from 60-minutes to 120-minutes due to post-meal exercise (energy consumption). After 120-minutes, the PPG moving direction of either upward or downward depends on the additional carbs/sugar intake and continuation of exercise activities. In this study, he has chosen to remove his collected PPG data and waveform after 120-minutes and conduct the time-domain (TD) analysis, spatial domain (SD) stress-strain analysis, along with the prediction of PPG by applying the viscoelastic perturbation model.

Here, he uses PPG as the strain and the carbs/sugar intake amount as the influential factor or viscosity factor. In order to include time-dependent characteristics, he uses the PPG change rate multiplied by a viscosity factor (4.1 grams for 240 liquid egg meals and 3.5 grams for 191 solid egg meals) in his stress-strain analysis and viscoelastic perturbation analysis.

To offer a simple explanation to readers who do not have a physics or engineering background, the author includes a brief excerpt from Wikipedia regarding the description of basic concepts for elasticity, plasticity, viscoelasticity, viscoplasticity, and perturbation theories from the disciplines of engineering and physics in the method section.

2. METHODS

2.1 Elasticity, plasticity, viscoelasticity and viscoplasticity

The difference between elastic materials and viscoelastic materials (from “Soborthans, innovating shock and vibration solutions”).

What are elastic materials?

Elasticity is the tendency of solid materials to return to their original shape after forces are applied on them. When the forces are removed, the object will return to its initial shape and size if the material is elastic.

What are viscous materials?

Viscosity is a measure of a fluid's resistance to flow. A fluid with large viscosity resists motion. A fluid with low viscosity flows. For example, water flows more easily than syrup because it has a lower viscosity. High viscosity materials might include honey, syrups, or gels – generally things that resist flow. Water is a low viscosity material, as it flows readily. Viscous materials are thick or sticky or adhesive. Since heating reduces viscosity, these materials don't flow easily. For example, warm syrup flows more easily than cold.

What is viscoelastic?

Viscoelasticity is the property of materials that exhibit both viscous and elastic characteristics when undergoing deformation. Synthetic polymers, wood, and human tissue, as well as metals at high temperature, display significant viscoelastic effects. In some applications, even a small viscoelastic response can be significant.

Elastic behavior versus viscoelastic behavior

The difference between elastic materials and viscoelastic materials is that viscoelastic materials have a viscosity factor and the elastic ones don't. Because viscoelastic materials have the viscosity factor, they have a strain rate dependent on time. Purely elastic materials do not dissipate energy (heat) when a load is applied, then removed; however, a viscoelastic substance does.

The following brief introductions are excerpts from Wikipedia:

“Elasticity (physics):

Physical property when materials or objects return to original shape after deformation.

In physics and materials science, elasticity is the ability of a body to resist a distorting influence and to return to its original size and shape when that influence or force is removed. Solid objects will deform when

adequate loads are applied to them; if the material is elastic, the object will return to its initial shape and size after removal. This is in contrast to plasticity, in which the object fails to do so and instead remains in its deformed state.

The physical reasons for elastic behavior can be quite different for different materials. In metals, the atomic lattice changes size and shape when forces are applied (energy is added to the system). When forces are removed, the lattice goes back to the original lower energy state. For rubbers and other polymers, elasticity is caused by the stretching of polymer chains when forces are applied.

Hooke's law states that the force required to deform elastic objects should be directly proportional to the distance of deformation, regardless of how large that distance becomes. This is known as perfect elasticity, in which a given object will return to its original shape no matter how strongly it is deformed. This is an ideal concept only; most materials which possess elasticity in practice remain purely elastic only up to very small deformations, after which plastic (permanent) deformation occurs.

In engineering, the elasticity of a material is quantified by the elastic modulus such as the Young's modulus, bulk modulus or shear modulus which measure the amount of stress needed to achieve a unit of strain; a higher modulus indicates that the material is harder to deform. The material's elastic limit or yield strength is the maximum stress that can arise before the onset of plastic deformation.

Plasticity (physics):

Deformation of a solid material undergoing non-reversible changes of shape in response to applied forces.

In physics and materials science, plasticity, also known as plastic deformation, is the ability of a solid material to undergo permanent deformation, a non-reversible change of shape in response to applied forces. For example, a solid piece of metal being bent or pounded into a new shape displays plasticity as permanent changes occur within the material itself. In engineering, the transition from elastic behavior to plastic behavior is known as yielding.

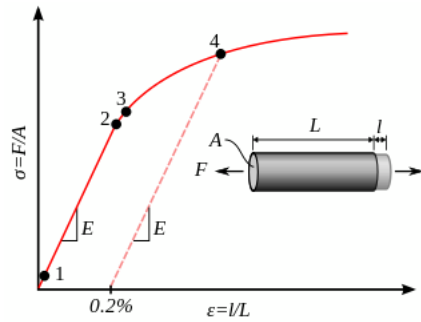

Stress–strain curve showing typical yield behavior for nonferrous alloys.

1. True elastic limit
2. Proportionality limit
3. Elastic limit
4. Offset yield strength

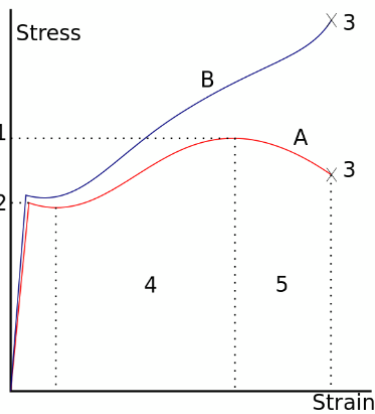

A stress–strain curve typical of structural steel.

- 1: Ultimate strength
- 2: Yield strength (yield point)
- 3: Rupture
- 4: Strain hardening region
- 5: Necking region
- A: Apparent stress (F/A_0)
- B: Actual stress (F/A)

Plastic deformation is observed in most materials, particularly metals, soils, rocks, concrete, and foams. However, the physical mechanisms that cause plastic deformation can vary widely. At a crystalline scale, plasticity in metals is usually a consequence of dislocations. Such defects are relatively rare in most crystalline materials, but are numerous in some and part of their crystal structure; in such cases, plastic crystallinity can result. In brittle materials such as rock, concrete and bone, plasticity is caused predominantly by slip at microcracks. In

cellular materials such as liquid foams or biological tissues, plasticity is mainly a consequence of bubble or cell rearrangements, notably T1 processes.

For many ductile metals, tensile loading applied to a sample will cause it to behave in an elastic manner. Each increment of load is accompanied by a proportional increment in extension. When the load is removed, the piece returns to its original size. However, once the load exceeds a threshold – the yield strength – the extension increases more rapidly than in the elastic region; now when the load is removed, some degree of extension will remain.

Elastic deformation, however, is an approximation and its quality depends on the time frame considered and loading speed. If, as indicated in the graph opposite, the deformation includes elastic deformation, it is also often referred to as "elasto-plastic deformation" or "elastic-plastic deformation".

Perfect plasticity is a property of materials to undergo irreversible deformation without any increase in stresses or loads. Plastic materials that have been hardened by prior deformation, such as cold forming, may need increasingly higher stresses to deform further. Generally, plastic deformation is also dependent on the deformation speed, i.e. higher stresses usually have to be applied to increase the rate of deformation. Such materials are said to deform viscoplastically.”

Viscoelasticity:

Property of materials with both viscous and elastic characteristics under deformation.

In materials science and continuum mechanics, viscoelasticity is the property of materials that exhibit both viscous and elastic characteristics when undergoing deformation. Viscous materials, like water, resist shear flow and strain linearly with time when a stress is applied. Elastic materials strain when stretched and immediately return to their original state once the stress is removed.

Viscoelastic materials have elements of both of these properties and, as such, exhibit time-dependent strain. Whereas elasticity is usually the result of bond stretching along

crystallographic planes in an ordered solid, viscosity is the result of the diffusion of atoms or molecules inside an amorphous material. In the nineteenth century, physicists such as Maxwell, Boltzmann, and Kelvin researched and experimented with creep and recovery of glasses, metals, and rubbers. Viscoelasticity was further examined in the late twentieth century when synthetic polymers were engineered and used in a variety of applications. Viscoelasticity calculations depend heavily on the viscosity variable, η . The inverse of η is also known as fluidity, ϕ . The value of either can be derived as a function of temperature or as a given value (i.e. for a dashpot).

Depending on the change of strain rate versus stress inside a material, the viscosity can be categorized as having a linear, non-linear, or plastic response. When a material exhibits a linear response it is categorized as a Newtonian material. In this case the stress is linearly proportional to the strain rate. If the material exhibits a non-linear response to the strain rate, it is categorized as Non-Newtonian fluid. There is also an interesting case where the viscosity decreases as the shear/strain rate remains constant. A material which exhibits this type of behavior is known as thixotropic. In addition, when the stress is independent of this strain rate, the material exhibits plastic deformation. Many viscoelastic materials exhibit rubber like behavior explained by the thermodynamic theory of polymer elasticity.

Cracking occurs when the strain is applied quickly and outside of the elastic limit. Ligaments and tendons are viscoelastic, so the extent of the potential damage to them depends both on the rate of the change of their length as well as on the force applied.

A viscoelastic material has the following properties:

- hysteresis is seen in the stress–strain curve
- stress relaxation occurs: step constant strain causes decreasing stress
- creep occurs: step constant stress causes increasing strain
- its stiffness depends on the strain rate or the stress rate.

Elastic versus viscoelastic behavior

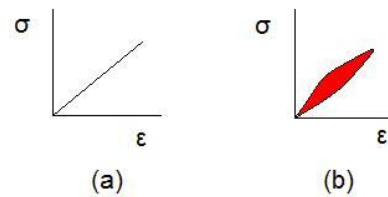

Stress–strain curves for a purely elastic material (a) and a viscoelastic material (b). The red area is a hysteresis loop and shows the amount of energy lost (as heat) in a loading and unloading cycle. It is equal to

$$\oint \sigma d\epsilon$$

where σ is stress and ϵ is strain.

Unlike purely elastic substances, a viscoelastic substance has an elastic component and a viscous component. The viscosity of a viscoelastic substance gives the substance a strain rate dependence on time. Purely elastic materials do not dissipate energy (heat) when a load is applied, then removed. However, a viscoelastic substance dissipates energy when a load is applied, then removed. Hysteresis is observed in the stress–strain curve, with the area of the loop being equal to the energy lost during the loading cycle. Since viscosity is the resistance to thermally activated plastic deformation, a viscous material will lose energy through a loading cycle. Plastic deformation results in lost energy, which is uncharacteristic of a purely elastic material's reaction to a loading cycle.

Specifically, viscoelasticity is a molecular rearrangement. When a stress is applied to a viscoelastic material such as a polymer, parts of the long polymer chain change positions. This movement or rearrangement is called “creep”. Polymers remain a solid material even when these parts of their chains are rearranging in order to accompany the stress, and as this occurs, it creates a back stress in the material. When the back stress is the same magnitude as the applied stress, the material no longer creeps. When the original stress is taken away, the accumulated back stresses will cause the polymer to return to its original form. The material creeps, which gives the prefix visco-, and the material fully recovers, which gives the suffix -elasticity.

Viscoplasticity:

Viscoplasticity is a theory in continuum mechanics that describes the rate-dependent inelastic behavior of solids. Rate-dependence in this context means that the deformation of the material depends on the rate at which loads are applied. The inelastic behavior that is the subject of viscoplasticity is plastic deformation which means that the material undergoes unrecoverable deformations when a load level is reached. Rate-dependent plasticity is important for transient plasticity calculations. The main difference between rate-independent plastic and viscoplastic material models is that the latter exhibit not only permanent deformations after the application of loads but continue to undergo a creep flow as a function of time under the influence of the applied load.

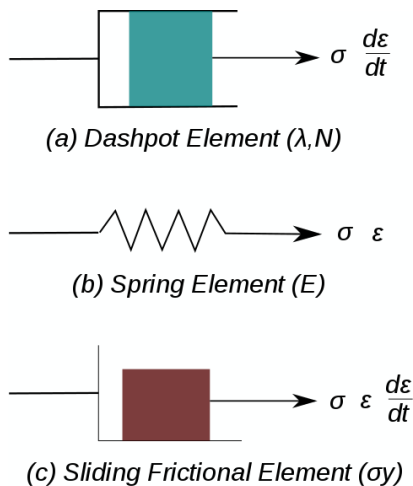

Figure 1. Elements used in one-dimensional models of viscoplastic materials.

The elastic response of viscoplastic materials can be represented in one-dimension by Hookean spring elements. Rate-dependence can be represented by nonlinear dashpot elements in a manner similar to viscoelasticity. Plasticity can be accounted for by adding sliding frictional elements as shown in Figure 1. In the figure E is the modulus of elasticity, λ is the viscosity parameter and N is a power-law type parameter that represents non-linear dashpot [$\sigma(d\epsilon/dt) = \sigma = \lambda(d\epsilon/dt)^{1/N}$]. The sliding element can have a yield stress (σ_y) that is strain rate dependent, or even constant, as shown in Figure 1c.

Viscoplasticity is usually modeled in three-dimensions using overstress models of the Perzyna or Duvaut-Lions types. In these models, the stress is allowed to increase beyond the rate-independent yield surface upon application of a load and then allowed to relax back to the yield surface over time. The yield surface is usually assumed not to be rate-dependent in such models. An alternative approach is to add a strain rate dependence to the yield stress and use the techniques of rate independent plasticity to calculate the response of a material.

For metals and alloys, viscoplasticity is the macroscopic behavior caused by a mechanism linked to the movement of dislocations in grains, with superposed effects of inter-crystalline gliding. The mechanism usually becomes dominant at temperatures greater than approximately one third of the absolute melting temperature. However, certain alloys exhibit viscoplasticity at room temperature (300K). For polymers, wood, and bitumen, the theory of viscoplasticity is required to describe behavior beyond the limit of elasticity or viscoelasticity.

In general, viscoplasticity theories are useful in areas such as

- the calculation of permanent deformations,
- the prediction of the plastic collapse of structures,
- the investigation of stability,
- crash simulations,
- systems exposed to high temperatures such as turbines in engines, e.g. a power plant,
- dynamic problems and systems exposed to high strain rates.

Phenomenology

For a qualitative analysis, several characteristic tests are performed to describe the phenomenology of viscoplastic materials. Some examples of these tests are

1. hardening tests at constant stress or strain rate,
2. creep tests at constant force, and
3. stress relaxation at constant elongation.

Strain hardening test

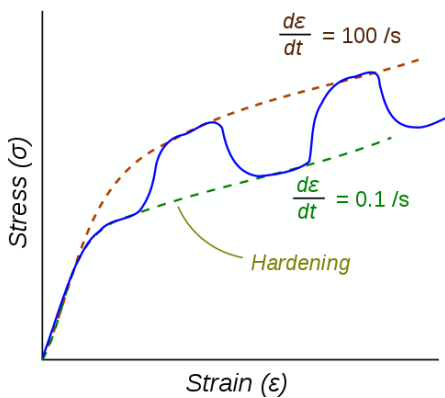

Figure 2. Stress–strain response of a viscoplastic material at different strain rates.

The dotted lines show the response if the strain-rate is held constant. The blue line shows the response when the strain rate is changed suddenly.

One consequence of yielding is that as plastic deformation proceeds, an increase in stress is required to produce additional strain. This phenomenon is known as Strain/Work hardening. For a viscoplastic material the hardening curves are not significantly different from those of rate-independent plastic material. Nevertheless, three essential differences can be observed.

1. At the same strain, the higher the rate of strain the higher the stress.
2. A change in the rate of strain during the test results in an immediate change in the stress–strain curve.
3. The concept of a plastic yield limit is no longer strictly applicable.

The hypothesis of partitioning the strains by decoupling the elastic and plastic parts is still applicable where the strains are small, i.e.,

$$\epsilon = \epsilon_e + \epsilon_{vp}$$

where ϵ_e is the elastic strain and ϵ_{vp} is the viscoplastic strain.

To obtain the stress–strain behavior shown in blue in the figure, the material is initially loaded at a strain rate of 0.1/s. The strain rate is then instantaneously raised to 100/s and held constant at that value for some time. At the end of that time period the strain rate is dropped instantaneously back to 0.1/s and

the cycle is continued for increasing values of strain. There is clearly a lag between the strain-rate change and the stress response. This lag is modeled quite accurately by overstress models (such as the Perzyna model) but not by models of rate-independent plasticity that have a rate-dependent yield stress.”

Perturbation theory:

This article is about perturbation theory as a general mathematical method. In mathematics and applied mathematics, perturbation theory comprises methods for finding an approximate solution to a problem, by starting from the exact solution of a related, simpler problem. A critical feature of the technique is a middle step that breaks the problem into "solvable" and "perturbative" parts. In perturbation theory, the solution is expressed as a power series in a small parameter ϵ . The first term is the known solution to the solvable problem. Successive terms in the series at higher powers of ϵ usually become smaller. An approximate 'perturbation solution' is obtained by truncating the series, usually by keeping only the first two terms, the solution to the known problem and the 'first order' perturbation correction.

Perturbation theory is used in a wide range of fields, and reaches its most sophisticated and advanced forms in quantum field theory. Perturbation theory (quantum mechanics) describes the use of this method in quantum mechanics. The field in general remains actively and heavily researched across multiple disciplines.

Description:

Perturbation theory develops an expression for the desired solution in terms of a formal power series known as a perturbation series in some "small" parameter, which quantifies the deviation from the exactly solvable problem. The leading term in this power series is the solution of the exactly solvable problem, while further terms describe the deviation in the solution, due to the deviation from the initial problem. Formally, we have for the approximation to the full solution A , a series in the small parameter (here called ϵ), like the following:

$$A = A_0 + \epsilon A_1 + \epsilon^2 A_2 + \dots$$

In this example, A_0 would be the known solution to the exactly solvable initial problem and A_1, A_2, \dots represent the first-order, second-order and higher-order terms, which may be found iteratively by a mechanistic procedure. For small ϵ these higher-order terms in the series generally (but not always) become successively smaller. An approximate "perturbative solution" is obtained by truncating the series, often by keeping only the first two terms, expressing the final solution as a sum of the initial (exact) solution and the "first-order" perturbative correction

$$A \approx A_0 + \epsilon A_1(\epsilon \rightarrow 0)$$

Some authors use big O notation to indicate the order of the error in the approximate solution:

$$A = A_0 + \epsilon A_1 + O(\epsilon^2).$$

If the power series in ϵ converges with a nonzero radius of convergence, the perturbation problem is called a regular perturbation problem. In regular perturbation problems, the asymptotic solution smoothly approaches the exact solution. However, the perturbation series can also diverge, and the truncated series can still be a good approximation to the true solution if it is truncated at a point at which its elements are minimum. This is called an asymptotic series. If the perturbation series is divergent or not a power series (e.g., the asymptotic expansion has non-integer powers $\epsilon^{1/2}$ or negative powers ϵ^{-2}) then the perturbation problem is called a singular perturbation problem. Many special techniques in perturbation theory have been developed to analyze singular perturbation problems."

Note: For a more detailed description, please refer to the "consolidated method" section which is given at the beginning of the special issue.

3. RESULTS

Figure 1 shows a data table of both input data and calculation results (upper table) and two types of egg meals (lower table): 2-hour time-span.

| 2/22/22 Liquid Egg Meals | | | | | | 2/22/22 Solid Egg Meals | | | | | |
|--------------------------|-----|--------|-------------|-----------|--|-------------------------|-----|--------|-------------|-----------|--|
| Strain | PPG | Stress | Carbs = 4.1 | Pred. PPG | | Strain | PPG | Stress | Carbs = 3.5 | Pred. PPG | |
| 0 min | 105 | 0.0 | 4.1 | 105 | | 0 min | 123 | 0.0 | 3.5 | 123 | |
| 15 min | 107 | 0.6 | 4.1 | 108 | | 15 min | 125 | 0.4 | 3.5 | 125 | |
| 30 min | 109 | 0.6 | 4.1 | 110 | | 30 min | 128 | 0.9 | 3.5 | 129 | |
| 45 min | 111 | 0.5 | 4.1 | 111 | | 45 min | 133 | 1.0 | 3.5 | 134 | |
| 60 min | 111 | 0.1 | 4.1 | 111 | | 60 min | 133 | 0.2 | 3.5 | 134 | |
| 75 min | 110 | -0.3 | 4.1 | 110 | | 75 min | 132 | -0.4 | 3.5 | 131 | |
| 90 min | 110 | -0.1 | 4.1 | 110 | | 90 min | 129 | -0.7 | 3.5 | 128 | |
| 105 min | 110 | -0.0 | 4.1 | 110 | | 105 min | 127 | -0.5 | 3.5 | 126 | |
| 120 min | 109 | -0.1 | 4.1 | 109 | | 120 min | 124 | -0.7 | 3.5 | 123 | |
| Average | 109 | 0.1 | 4.1 | 109 | | Average | 128 | 0.0 | 3.5 | 128 | |
| Correlation | | | | 99% | | Correlation | | | 100% | 99% | |

| Egg Meals | Liquid PPG | Solid PPG | Egg Meals | Liquid PPG | Pred. L. PPG | Solid PPG | Pred. S. PPG |
|-------------|------------|-----------|-------------|------------|--------------|-----------|--------------|
| 0 min | 105 | 123 | 0 min | 105 | 105 | 123 | 123 |
| 15 min | 107 | 125 | 15 min | 107 | 108 | 125 | 125 |
| 30 min | 109 | 128 | 30 min | 109 | 110 | 128 | 129 |
| 45 min | 111 | 133 | 45 min | 111 | 111 | 133 | 134 |
| 60 min | 111 | 133 | 60 min | 111 | 111 | 133 | 134 |
| 75 min | 110 | 132 | 75 min | 110 | 110 | 132 | 131 |
| 90 min | 110 | 129 | 90 min | 110 | 110 | 129 | 128 |
| 105 min | 110 | 127 | 105 min | 110 | 110 | 127 | 126 |
| 120 min | 109 | 124 | 120 min | 109 | 109 | 124 | 123 |
| Average | 109 | 128 | Average | 109 | 109 | 128 | 128 |
| Correlation | | 83% | Correlation | | 99% | | 99% |

| | | | | | | | | | | | |
|----------|---------------|------|------------|--------|----|----------|------------------------------|------|------------|--------|----|
| Date | 05/01/2018 | ~ | 02/21/2022 | Yes | No | Date | 05/01/2018 | ~ | 02/21/2022 | Yes | No |
| Glucose | | | | Yes | No | Glucose | | | | Yes | No |
| Meal(g) | | | | Yes | No | Meal(g) | | | | Yes | No |
| Keyword | Egg drop soup | | | Yes | No | Keyword | Pan-fried egg, hard broil... | | | Yes | No |
| Key(w/o) | | | | Yes | No | Key(w/o) | | | | Yes | No |
| Type | | | | Yes | No | Type | | | | Yes | No |
| Meal | All | Bkst | Lunch | Dinner | | Meal | All | Bkst | Lunch | Dinner | |

Figure 1: Data table of both input data and calculation results (upper table) and two types of egg meals (lower table): 2-hour time-span.

Figure 2 reflect the TD display (upper diagram) and Stress-strain diagrams (lower diagram) of measured PPG from 240 liquid egg meals and 191 solid egg meals: 2-hour time-span.

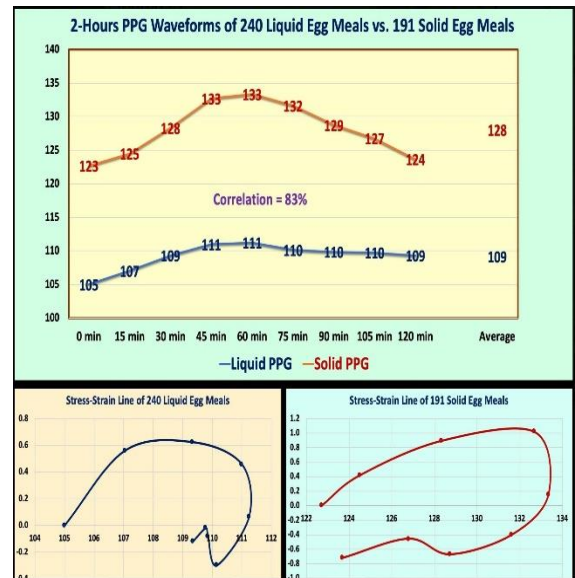

Figure 2: Time-domain display (upper diagram) and stress-strain diagrams (lower diagram) of measured PPG from 240 liquid egg meals and 191 solid egg meals: 2-hour time-span.

Figure 3 depicts two egg meals time-domain diagrams of both measured PPG and predicted PPG using viscoelastic perturbation model: 2-hour time-span.

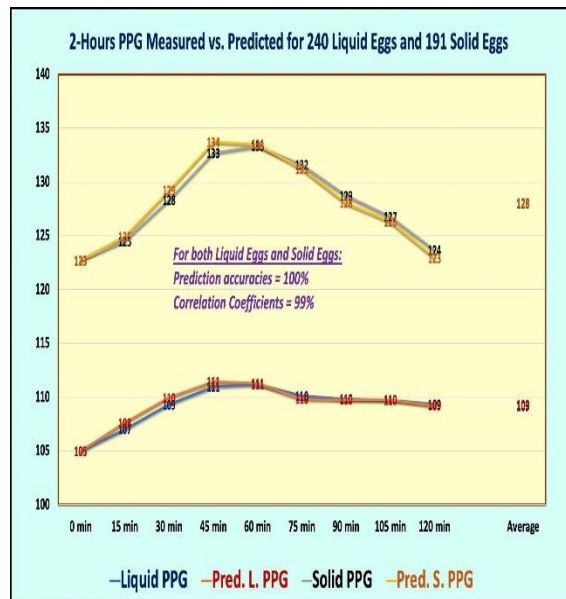

Figure 3: Time-domain diagrams of both measured PPG and predicted PPG using viscoelastic perturbation model: 2-hour time-span.

4. CONCLUSION

In conclusion, the author has defined his stress-strain equations as follows:

Strain

$$= \epsilon$$

= (sensor PPG value) at each time interval

Viscosity factor

$$= \eta$$

= (average carbs/sugar intake grams) of each type of egg meals

However, he has utilized the PPG change rate multiplied with the above-described viscosity factor to obtain the stress:

Stress

$$= \eta * (d\epsilon/dt)$$

$$= \eta * (d\text{-strain}/d\text{-time})$$

= ((viscosity factor of present month) * (PPG of present time interval - PPG of previous time interval) / 15)

Where 15 indicates the 15-minute time intervals of his collected PPG data.

Based on stress-strain analysis in both TD and SD by applying theory of viscoelasticity or viscoplasticity, and viscoelastic perturbation model, the following 3 distinct observations are evident:

(1) In the TD display of PPG waveforms, the PPG waveform of 191 solid egg meals has

higher values of average PPG, initial PPG, peak PPG, and ending PPG, than the PPG waveforms of 240 liquid egg meals. This observed biophysical phenomenon can be interpreted using the brain neuro-scientific explanation. Interestingly, the correlation of the two PPG waveforms within the 2-hour time span is +83% which indicates high correlation (for the 3-hour PPG time span, the correlation is -23% due to the PPG segment between 120-minutes and 180-minutes).

(2) Observing the two stress-strain diagrams in SD, the measured PPG using carbs/sugar grams as the viscosity factor have shown two similar hysteresis loops but still somewhat different looks in their curve shapes. For the 240 liquid egg meals, the viscoplastic stress-strain curve has 4 mg/dL strain gap (i.e. PPG difference) between the initial PPG at 0-minute and the ending PPG at 120-minutes. Whereas the 191 solid egg meals, the viscoelastic stress-strain curve looks more like a “standard” hysteresis loop generated from his overall PPG curve with viscoelastic behavior (starting PPG at 0-minute and PPG at 120-minutes are remarkably close to each other) which has only 1 mg/dL strain gap. Interestingly, it has also demonstrated both the stress-creeping phenomenon (upper portion) and the strain-relaxation phenomenon (right portion).

(3) The predicted PPG values using viscoelastic perturbation method have achieved extremely high prediction accuracy of 100% for both 240 liquid egg meals and 191 solid egg meals. Their correlation coefficients are 99% for both 240 liquid egg meals and 191 solid egg meals. This indicates that the predicted PPG values using a viscoelastic perturbation model have reached high prediction accuracy and high waveform similarity.

In summary, while researching brain neuroscience, the author also utilized an average carbs/sugar intake amount as the viscosity factor and applied the viscoelastic perturbation model to analyze the 2-hour PPG data and waveform. As a result, he could produce a highly satisfactory prediction for PPG.

5. REFERENCES

For editing purposes, the majority of the references in this paper, which are self-references, have been removed. Only references from other authors' published sources remain. The bibliography of the author's original self-references can be viewed at www.eclairemd.com.

Readers may use this article as long as the work is properly cited, and their use is educational and not for profit, and the author's original work is not altered.

6. ACKNOWLEDGEMENT

Without Professor Norman Jones at MIT as his academic advisor, the author would not be able to conduct his medical research project and also published 500+ research papers. The author has never forgotten his advice to him that he should always enhance his strength on foundations, such as mathematics and physics, in order to make further improvement and advancement. Professor Jones has also provided him with a personal example of doing outstanding teaching and research jobs with an excellent work attitude, extreme dedication, and ultimate commitment to advancing both science and engineering.

Viscoelastic and Viscoplastic Glucose Theory Application in Medicine

Gerald C. Hsu

