

The GH-Method

Viscoelastic or Viscoplastic Glucose Theory (VGT #41): Applying VGT to Study the Relationship of CVD Risk Probability % versus Sensor Daily Average Glucose (eAG) and its Calculated HbA1C, While Using the Viscoelastic Perturbation Model to Predict Two CVD Risk % Values Over a 15-Month Period from October of Y2020 to February of Y2022 Based on the GH-Method: Math-Physical Medicine (No. 622)

Gerald C. Hsu*

eclairMD Foundation, USA

Note: Readers who want to get a quick overview can read the abstract, results, and graphs.

Abstract

Since 2012, the author has been collecting his body weight (m1) and finger-piercing glucose values (m2) each day. In addition, he accumulates medical conditions data including a combination of data for blood pressure (BP) and heart rate (HR), and blood lipids along with lifestyle details of diet, exercise, sleep, stress, water intake and daily routine details. Based on the collected big data, he further organized them into two main groups. The first group is medical conditions (MC) with 4 categories: weight, glucose, BP, and blood lipids. The second group is lifestyle details (LD) with 6 categories: food & diet, exercise, water intake, sleep, stress, and daily routines. He collects his daily data and then calculates a unique combined score for each MC and LD with their 10 categories. The combined scores of the 2 groups, 10 categories, and 500+ elements constitute an overall "metabolism index (MI) model". This MI model includes the root causes of 6 lifestyle inputs and 4 symptoms of the disease including the rudimentary chronic diseases: obesity, diabetes, hypertension, and hyperlipidemia. As we know, lifestyle details cause rudimentary chronic diseases which further influence more complicated diseases, such as heart problems (CVD & CHD), chronic kidney disease (CKD), stroke, diabetic retinopathy (DR), neuropathy, hypothyroidism, and others. However, in addition to the lifestyle-induced chronic disease and complications, environmental factors, such as radiation, air and water pollution, food poison and pollution, toxic chemicals, and hormonal therapy, can contribute to the causes for a variety of cancer. Some genetic conditions and lifetime unhealthy habits, such as smoking, alcohol consumption, illicit drug use

would account for approximately 15% to 25% of the root cause for rudimentary chronic diseases, complications, and cancer. All of the above-described diseases fall into the "symptoms" category which are the "root-causes" due to poor and unhealthy lifestyles. In this article, the author applies the viscoelasticity and viscoplasticity theories to conduct his research to discover some hidden behavior or possible relationship among 3 key biomarkers, CVD risk % (a symptom disease), sensor daily average glucose (eAG), and its related sensor HbA1C (A1C). The hidden behaviors and possible inter-relationships among the three biomarkers are "time-dependent" which change from time to time. This is why he applies viscoelastic & viscoplastic theories (VGT) to conduct his recent research work. The author previously conducted similar analyses for this set of biomarkers but used a traditional statistical regression method. Generally speaking, statistical methods only deal with numerical characteristics of collected datasets and do not influence the internal physical characteristics. Incidentally, the accuracy and applicability of using any statistical analysis results are heavily dependent on characteristics of the data sample, data sample size, and the time-window of the dataset. Therefore, we must be careful in selecting appropriate statistical methods and treat their analysis conclusions cautiously. For example, in this analysis, the author has performed two basic correlation analyses of the same dataset for three biomarkers, CVD risk, eAG, and A1C, but chose two different time-windows. The following displayed results show the vast differences between the two statistical correlation analysis

Received: 13 June 2022, Accepted: 20 July 2022, Available online: 23 July 2022

*Corresponding author: Gerald C. Hsu, eclairMD Foundation, USA

results: (1) Correlations using 1,303 days from 8/8/2018 to 3/3/2022: CVD vs. eAG = 70%; CVD/A1C = 70%; eAG vs. A1C = 99%. (2) Correlations using 15 months (516 days) from 10/1/2020 to 2/28/2022: CVD vs. eAG = -31%; CVD/A1C = -29%; eAG vs. A1C = 70%. Obviously, the wider time-window which consists of more data provides a better understanding of the inner-characteristics and a more accurate result. The following defined equations are used to establish the stress-strain diagram in a space-domain (SD): Strain = ε (CVD risk %) = individual CVD risk at present time. Stress = σ (based on change rate of strain, CVD risk, multiplying with a viscosity factor, eAG or A1C) = $\eta * (d\varepsilon/dt) = \eta * (d\text{-strain}/d\text{-time})$ = (viscosity factor η using individual eAG or A1C at present time) * (CVD risk at present time - CVD risk at previous time). Next, he applies the viscoelastic perturbation model to calculate the following predicted CVD risk %. Perturbed or predicted CVD risk % = strain value (CVD risk) at present year + stress value at present year (i.e., CVD risk change rate * eAG or A1C) * amplification factor, where the selected amplification factor for A1C is 1.0 and for eAG is 0.05 which makes the two stress scales (Y-axis scales) on even ground. To offer a simple explanation to readers who do not have a physics or engineering background, the author includes a brief excerpt from Wikipedia regarding the description of basic concepts for elasticity and plasticity theories, viscoelasticity and viscoplasticity theories from the disciplines of engineering and physics in the method section. In conclusion, the following four observations outline the findings from this research work: (1) From the time-domain (TD) waveforms, over a 15-month period from 10/1/2020 to 2/28/2022, three

correlations among CVD risk, eAG, A1C are: CVD vs. eAG = -31%, CVD vs. A1C = -29%, eAG vs. A1C = 70%. These two lower negative correlations already provided a hint that this analysis would not be able to provide useful information. (2) However, as discussed in the Introduction section, if he selects a wider time-window of 1,303 days from 8/8/2018 to 3/3/2022, three different correlations among CVD risk, eAG, A1C are: CVD vs. eAG = 70%, CVD vs. A1C = 70%, eAG vs. A1C = 99%. If he conducts a similar analysis using this dataset, he estimates that the analysis results would be different. (3) In the SD stress-strain diagrams, due to his modified viscosity factor (η) of eAG by multiplying a modification factor of 0.05 (or dividing by 20) on eAG, his two stress scales (Y-axis scales) are extremely close to each other; therefore, the two stress-strain curves are almost identical. In addition, the two stress-strain curves have demonstrated viscoplastic behavior. (4) Using the viscoelastic perturbation model, a waveform comparison study of the metabolism calculated CVD risk % against two predicted CVD risks can be done. (a) Using the visco-perturbation model, the calculated CVD risk versus the predicted CVD risk based on eAG has a 42% correlation and 98% prediction accuracy. (b) Using the visco-perturbation model, the calculated CVD risk versus the predicted CVD risk based on A1C has a 41% correlation and 98% prediction accuracy. In summary, this analysis shows that his research based on this 15-month dataset (Figure 3) would result in unsatisfactory results. However, the CVD risk % has higher correlations with both eAG and A1C (see Figure 2). As a result, he will continue the same research work but using a different dataset with a wider time-window of collected data.

Keywords: Viscoelastic; Viscoplastic; Daily average glucose; Cardiovascular disease; HbA1C

Abbreviations: BP: blood pressure; HR: heart rate; CVD: cardiovascular disease; MC: medical conditions; LD: lifestyle details; MI: metabolism index; eAG: daily average glucose; SD: space-domain; TD: time-domain; MPM: math-physical medicine

1. INTRODUCTION

Since 2012, the author has been collecting his body weight (m1) and finger-piercing glucose values (m2) each day. In addition, he accumulates medical conditions data including a combination of data for blood pressure (BP) and heart rate (HR), and blood lipids along with lifestyle details of diet, exercise, sleep, stress, water intake and daily routine details. Based on the collected big data, he further organized them into two main groups. The first group is medical conditions (MC) with 4 categories: weight, glucose, BP, and blood lipids. The second group is lifestyle details (LD) with 6 categories: food & diet, exercise, water intake, sleep, stress, and daily routines. He collects his daily data and then calculates a unique combined score for each MC and LD with their 10 categories. The combined scores of the 2 groups, 10 categories, and 500+ elements constitute an overall “metabolism index (MI) model”. This MI model includes the root causes of 6 lifestyle inputs and 4 symptoms of the disease including the rudimentary chronic diseases: obesity, diabetes, hypertension, and hyperlipidemia.

As we know, lifestyle details cause rudimentary chronic diseases which further influence more complicated diseases, such as heart problems (CVD & CHD), chronic kidney disease (CKD), stroke, diabetic retinopathy (DR), neuropathy, hypothyroidism, and others. However, in addition to the lifestyle-induced chronic disease and complications, environmental factors, such as radiation, air and water pollution, food poison and pollution, toxic chemicals, and hormonal therapy, can contribute to the causes for a variety of cancer. Some genetic conditions and lifetime unhealthy habits, such as smoking, alcohol consumption, illicit drug use would account for approximately 15% to 25% of the root cause for rudimentary chronic diseases, complications, and cancer. All of the above-described diseases fall into the “symptoms” category which are the “root-causes” due to poor and unhealthy lifestyles.

In this article, the author applies the viscoelasticity and viscoplasticity theories to conduct his research to discover some hidden behavior or possible relationship among 3 key

biomarkers, CVD risk % (a symptom disease), daily average sensor glucose (eAG), and its related sensor HbA1C (A1C). The hidden behaviors and possible inter-relationships among the three biomarkers are “time-dependent” which change from time to time. This is why he applies viscoelastic & viscoplastic theories (VGT) to conduct his recent research work.

The author previously conducted similar analyses for this set of biomarkers but used a traditional statistical regression method. Generally speaking, statistical methods only deal with numerical characteristics of collected datasets and do not influence the internal physical characteristics. Incidentally, the accuracy and applicability of using any statistical analysis results are heavily dependent on characteristics of the data sample, data sample size, and the time-window of the dataset. Therefore, we must be careful in selecting appropriate statistical methods and treat their analysis conclusions cautiously.

For example, in this analysis, the author has performed two basic correlation analyses of the same dataset for three biomarkers, CVD risk, eAG, and A1C, but chose two different time-windows. The following displayed results show the vast differences between the two statistical correlation analysis results:

(1) Correlations using 1,303 days from 8/8/2018 to 3/3/2022: CVD vs. eAG = 70%; CVD/A1C = 70%; eAG vs. A1C = 99%

(2) Correlations using 15 months (516 days) from 10/1/2020 to 2/28/2022: CVD vs. eAG = -31%; CVD/A1C = -29%; eAG vs. A1C = 70%

Obviously, the wider time-window which consists of more data provides a better understanding of the inner-characteristics and a more accurate result.

The following defined equations are used to establish the stress-strain diagram in a space-domain (SD):

Strain
 = ϵ (CVD risk %)
 = individual CVD risk at present time

Stress

= σ (based on change rate of strain, CVD risk, multiplying with a viscosity factor, eAG or A1C)
 = $\eta * (d\epsilon/dt)$
 = $\eta * (d\text{-strain}/d\text{-time})$
 = (viscosity factor η using individual eAG or A1C at present time) * (CVD risk at present time - CVD risk at previous time)

Next, he applies the viscoelastic perturbation model to calculate the following predicted CVD risk %.

Perturbed or predicted CVD risk %

= strain value (CVD risk) at present year + stress value at present year (i.e., CVD risk change rate * eAG or A1C) * amplification factor

Where the selected amplification factor for A1C is 1.0 and for eAG is 0.05 which makes the two stress scales (Y-axis scales) on even ground.

To offer a simple explanation to readers who do not have a physics or engineering background, the author includes a brief excerpt from Wikipedia regarding the description of basic concepts for elasticity and plasticity theories, viscoelasticity and viscoplasticity theories from the disciplines of engineering and physics in the method section.

2. METHODS

2.1 Elasticity, plasticity, viscoelasticity and viscoplasticity

The difference between elastic materials and viscoelastic materials (from “Soborthans, innovating shock and vibration solutions”).

What are elastic materials?

Elasticity is the tendency of solid materials to return to their original shape after forces are applied on them. When the forces are removed, the object will return to its initial shape and size if the material is elastic.

What are viscous materials?

Viscosity is a measure of a fluid’s resistance to flow. A fluid with large viscosity resists motion. A fluid with low viscosity flows. For example, water flows more easily than syrup

because it has a lower viscosity. High viscosity materials might include honey, syrups, or gels – generally things that resist flow. Water is a low viscosity material, as it flows readily. Viscous materials are thick or sticky or adhesive. Since heating reduces viscosity, these materials don’t flow easily. For example, warm syrup flows more easily than cold.

What is viscoelastic?

Viscoelasticity is the property of materials that exhibit both viscous and elastic characteristics when undergoing deformation. Synthetic polymers, wood, and human tissue, as well as metals at high temperature, display significant viscoelastic effects. In some applications, even a small viscoelastic response can be significant.

Elastic behavior versus viscoelastic behavior

The difference between elastic materials and viscoelastic materials is that viscoelastic materials have a viscosity factor and the elastic ones don’t. Because viscoelastic materials have the viscosity factor, they have a strain rate dependent on time. Purely elastic materials do not dissipate energy (heat) when a load is applied, then removed; however, a viscoelastic substance does.

The following brief introductions are excerpts from Wikipedia:

“Elasticity (physics):

The physical property when materials or objects return to original shape after deformation.

In physics and materials science, elasticity is the ability of a body to resist a distorting influence and to return to its original size and shape when that influence or force is removed. Solid objects will deform when adequate loads are applied to them; if the material is elastic, the object will return to its initial shape and size after removal. This is in contrast to plasticity, in which the object fails to do so and instead remains in its deformed state.

The physical reasons for elastic behavior can be quite different for different materials. In metals, the atomic lattice changes size and shape when forces are applied (energy is

added to the system). When forces are removed, the lattice goes back to the original lower energy state. For rubbers and other polymers, elasticity is caused by the stretching of polymer chains when forces are applied.

Hooke's law states that the force required to deform elastic objects should be directly proportional to the distance of deformation, regardless of how large that distance becomes. This is known as perfect elasticity, in which a given object will return to its original shape no matter how strongly it is deformed. This is an ideal concept only; most materials which possess elasticity in practice remain purely elastic only up to very small deformations, after which plastic (permanent) deformation occurs.

In engineering, the elasticity of a material is quantified by the elastic modulus such as the Young's modulus, bulk modulus or shear modulus which measure the amount of stress needed to achieve a unit of strain; a higher modulus indicates that the material is harder to deform. The material's elastic limit or yield strength is the maximum stress that can arise before the onset of plastic deformation.

Plasticity (physics):

Deformation of a solid material undergoing non-reversible changes of shape in response to applied forces.

In physics and materials science, plasticity, also known as plastic deformation, is the ability of a solid material to undergo permanent deformation, a non-reversible change of shape in response to applied forces. For example, a solid piece of metal being bent or pounded into a new shape displays plasticity as permanent changes occur within the material itself. In engineering, the transition from elastic behavior to plastic behavior is known as yielding.

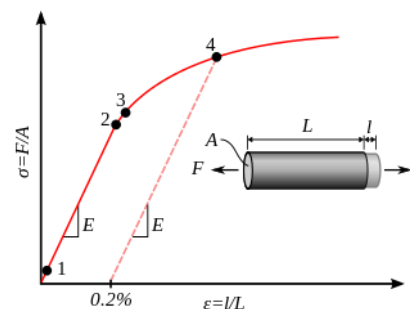

Stress–strain curve showing typical yield behavior for nonferrous alloys.

1. True elastic limit
2. Proportionality limit
3. Elastic limit
4. Offset yield strength

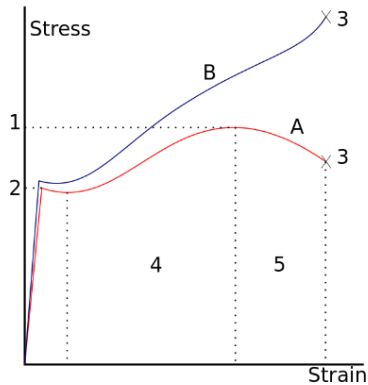

A stress–strain curve typical of structural steel.

- 1: Ultimate strength
- 2: Yield strength (yield point)
- 3: Rupture
- 4: Strain hardening region
- 5: Necking region
- A: Apparent stress (F/A0)
- B: Actual stress (F/A)

Plastic deformation is observed in most materials, particularly metals, soils, rocks, concrete, and foams. However, the physical mechanisms that cause plastic deformation can vary widely. At a crystalline scale, plasticity in metals is usually a consequence of dislocations. Such defects are relatively rare in most crystalline materials, but are numerous in some and part of their crystal structure; in such cases, plastic crystallinity can result. In brittle materials such as rock, concrete and bone, plasticity is caused predominantly by slip at microcracks. In cellular materials such as liquid foams or biological tissues, plasticity is mainly a consequence of bubble or cell rearrangements, notably T1 processes.

For many ductile metals, tensile loading applied to a sample will cause it to behave in an elastic manner. Each increment of load is accompanied by a proportional increment in extension. When the load is removed, the piece returns to its original size. However, once the load exceeds a threshold – the yield strength – the extension increases more

rapidly than in the elastic region; now when the load is removed, some degree of extension will remain.

Elastic deformation, however, is an approximation and its quality depends on the time frame considered and loading speed. If, as indicated in the graph opposite, the deformation includes elastic deformation, it is also often referred to as "elasto-plastic deformation" or "elastic-plastic deformation".

Perfect plasticity is a property of materials to undergo irreversible deformation without any increase in stresses or loads. Plastic materials that have been hardened by prior deformation, such as cold forming, may need increasingly higher stresses to deform further. Generally, plastic deformation is also dependent on the deformation speed, i.e. higher stresses usually have to be applied to increase the rate of deformation. Such materials are said to deform viscoplastically."

Viscoelasticity:

Property of materials with both viscous and elastic characteristics under deformation.

In materials science and continuum mechanics, viscoelasticity is the property of materials that exhibit both viscous and elastic characteristics when undergoing deformation. Viscous materials, like water, resist shear flow and strain linearly with time when a stress is applied. Elastic materials strain when stretched and immediately return to their original state once the stress is removed.

Viscoelastic materials have elements of both of these properties and, as such, exhibit time-dependent strain. Whereas elasticity is usually the result of bond stretching along crystallographic planes in an ordered solid, viscosity is the result of the diffusion of atoms or molecules inside an amorphous material.

In the nineteenth century, physicists such as Maxwell, Boltzmann, and Kelvin researched and experimented with creep and recovery of glasses, metals, and rubbers. Viscoelasticity was further examined in the late twentieth century when synthetic polymers were engineered and used in a variety of applications. Viscoelasticity calculations depend heavily on the viscosity variable, η .

The inverse of η is also known as fluidity, ϕ . The value of either can be derived as a function of temperature or as a given value (i.e., for a dashpot).

Depending on the change of strain rate versus stress inside a material, the viscosity can be categorized as having a linear, non-linear, or plastic response. When a material exhibits a linear response, it is categorized as a Newtonian material. In this case the stress is linearly proportional to the strain rate. If the material exhibits a non-linear response to the strain rate, it is categorized as non-Newtonian fluid. There is also an interesting case where the viscosity decreases as the shear/strain rate remains constant. A material which exhibits this type of behavior is known as thixotropic. In addition, when the stress is independent of this strain rate, the material exhibits plastic deformation. Many viscoelastic materials exhibit rubber like behavior explained by the thermodynamic theory of polymer elasticity.

Cracking occurs when the strain is applied quickly and outside of the elastic limit. Ligaments and tendons are viscoelastic, so the extent of the potential damage to them depends both on the rate of the change of their length as well as on the force applied.

A viscoelastic material has the following properties:

- hysteresis is seen in the stress–strain curve
- stress relaxation occurs: step constant strain causes decreasing stress
- creep occurs: step constant stress causes increasing strain
- its stiffness depends on the strain rate or the stress rate.

Elastic versus viscoelastic behavior

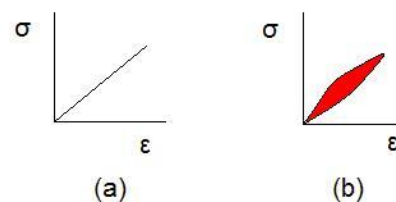

Stress–strain curves for a purely elastic material (a) and a viscoelastic material (b). The red area is a hysteresis loop and shows

the amount of energy lost (as heat) in a loading and unloading cycle. It is equal to

$$\oint \sigma d\varepsilon$$

where σ is stress and ε is strain.

Unlike purely elastic substances, a viscoelastic substance has an elastic component and a viscous component. The viscosity of a viscoelastic substance gives the substance a strain rate dependence on time. Purely elastic materials do not dissipate energy (heat) when a load is applied, then removed. However, a viscoelastic substance dissipates energy when a load is applied, then removed. Hysteresis is observed in the stress-strain curve, with the area of the loop being equal to the energy lost during the loading cycle. Since viscosity is the resistance to thermally activated plastic deformation, a viscous material will lose energy through a loading cycle. Plastic deformation results in lost energy, which is uncharacteristic of a purely elastic material's reaction to a loading cycle.

Specifically, viscoelasticity is a molecular rearrangement. When a stress is applied to a viscoelastic material such as a polymer, parts of the long polymer chain change positions. This movement or rearrangement is called "creep". Polymers remain a solid material even when these parts of their chains are rearranging in order to accompany the stress, and as this occurs, it creates a back stress in the material. When the back stress is the same magnitude as the applied stress, the material no longer creeps. When the original stress is taken away, the accumulated back stresses will cause the polymer to return to its original form. The material creeps, which gives the prefix visco-, and the material fully recovers, which gives the suffix -elasticity.

Viscoplasticity:

Viscoplasticity is a theory in continuum mechanics that describes the rate-dependent inelastic behavior of solids. Rate-dependence in this context means that the deformation of the material depends on the rate at which loads are applied. The inelastic behavior that is the subject of viscoplasticity is plastic deformation which means that the material undergoes unrecoverable deformations when a load level is reached. Rate-dependent plasticity is important for transient plasticity calculations. The main difference between

rate-independent plastic and viscoplastic material models is that the latter exhibit not only permanent deformations after the application of loads but continue to undergo a creep flow as a function of time under the influence of the applied load.

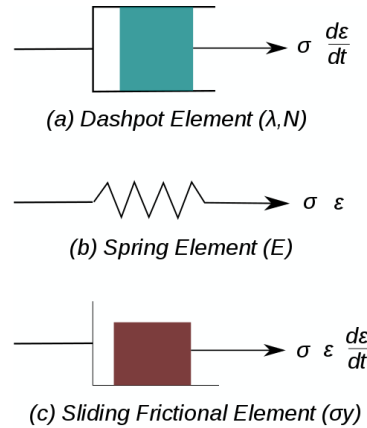

Figure 1. Elements used in one-dimensional models of viscoplastic materials.

The elastic response of viscoplastic materials can be represented in one-dimension by Hookean spring elements. Rate-dependence can be represented by nonlinear dashpot elements in a manner similar to viscoelasticity. Plasticity can be accounted for by adding sliding frictional elements as shown in Figure 1. In the figure E is the modulus of elasticity, λ is the viscosity parameter and N is a power-law type parameter that represents non-linear dashpot [$\sigma(d\varepsilon/dt) = \sigma = \lambda(d\varepsilon/dt)^{1/N}$]. The sliding element can have a yield stress (σ_y) that is strain rate dependent, or even constant, as shown in Figure 1c.

Viscoplasticity is usually modeled in three-dimensions using overstress models of the Perzyna or Duvaut-Lions types. In these models, the stress is allowed to increase beyond the rate-independent yield surface upon application of a load and then allowed to relax back to the yield surface over time. The yield surface is usually assumed not to be rate-dependent in such models. An alternative approach is to add a strain rate dependence to the yield stress and use the techniques of rate independent plasticity to calculate the response of a material.

For metals and alloys, viscoplasticity is the macroscopic behavior caused by a mechanism linked to the movement of dislocations in

grains, with superposed effects of inter-crystalline gliding. The mechanism usually becomes dominant at temperatures greater than approximately one third of the absolute melting temperature. However, certain alloys exhibit viscoplasticity at room temperature (300K). For polymers, wood, and bitumen, the theory of viscoplasticity is required to describe behavior beyond the limit of elasticity or viscoelasticity.

In general, viscoplasticity theories are useful in areas such as

- the calculation of permanent deformations,
- the prediction of the plastic collapse of structures,
- the investigation of stability,
- crash simulations,
- systems exposed to high temperatures such as turbines in engines, e.g. a power plant,
- dynamic problems and systems exposed to high strain rates.

Phenomenology

For a qualitative analysis, several characteristic tests are performed to describe the phenomenology of viscoplastic materials. Some examples of these tests are

1. hardening tests at constant stress or strain rate,
2. creep tests at constant force, and
3. stress relaxation at constant elongation.

Strain hardening test

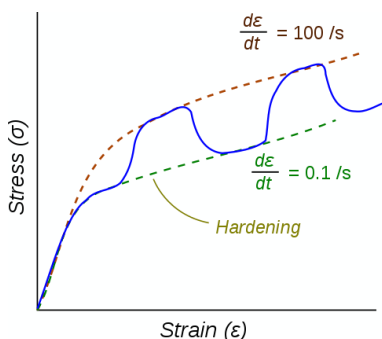

Figure 2. Stress–strain response of a viscoplastic material at different strain rates.

The dotted lines show the response if the strain-rate is held constant. The blue line

shows the response when the strain rate is changed suddenly.

One consequence of yielding is that as plastic deformation proceeds, an increase in stress is required to produce additional strain. This phenomenon is known as Strain/Work hardening. For a viscoplastic material the hardening curves are not significantly different from those of rate-independent plastic material. Nevertheless, three essential differences can be observed.

1. At the same strain, the higher the rate of strain the higher the stress.
2. A change in the rate of strain during the test results in an immediate change in the stress–strain curve.
3. The concept of a plastic yield limit is no longer strictly applicable.

The hypothesis of partitioning the strains by decoupling the elastic and plastic parts is still applicable where the strains are small, i.e.,

$$\varepsilon = \varepsilon_e + \varepsilon_{vp}$$

where ε_e is the elastic strain and ε_{vp} is the viscoplastic strain.

To obtain the stress–strain behavior shown in blue in the figure, the material is initially loaded at a strain rate of 0.1/s. The strain rate is then instantaneously raised to 100/s and held constant at that value for some time. At the end of that time period the strain rate is dropped instantaneously back to 0.1/s and the cycle is continued for increasing values of strain. There is clearly a lag between the strain-rate change and the stress response. This lag is modeled quite accurately by overstress models (such as the Perzyna model) but not by models of rate-independent plasticity that have a rate-dependent yield stress.”

Note: For a more detailed description, please refer to the “consolidated method” section which is given at the beginning of the special issue.

3. RESULTS

Figure 1 displays the data table and calculated results of this study.

11/25/21	Y	X1	X2	11/25/21	Strain	Stress 1	Stress 2	11/25/21	Strain (CVD)	Stress (CVD)	11/25/21	Strain (CVD)	Stress (CVD)	11/25/21
Period	CVD Risk %	Libre A1C	Libre eAG	Period	Strain (CVD)	Stress (A1C)	Stress (eAG/20)	Period	Calculated CVD	Pred. CVD (A1C)	Pred. CVD (eAG)	Period	Pred. CVD (eAG)	
Y2020M10	48	5.9	107	Y2020M10	48	0.0	0.0	Y2020M10	48	48	48	Y2020M10	48	
Y2020M11	48	5.8	106	Y2020M11	48	-1.7	-1.6	Y2020M11	48	46	46	Y2020M11	46	
Y2020M12	50	5.9	116	Y2020M12	50	11.1	12.8	Y2020M12	50	63	63	Y2020M12	63	
Y2021M01	52	6.0	119	Y2021M01	52	10.2	10.1	Y2021M01	52	62	62	Y2021M01	62	
Y2021M02	49	6.3	121	Y2021M02	49	-16.1	-18.3	Y2021M02	49	29	30	Y2021M02	30	
Y2021M03	50	6.4	120	Y2021M03	50	10.4	9.7	Y2021M03	50	61	60	Y2021M03	60	
Y2021M04	52	6.5	114	Y2021M04	52	11.1	11.0	Y2021M04	52	66	66	Y2021M04	66	
Y2021M05	53	6.2	109	Y2021M05	53	7.7	6.8	Y2021M05	53	61	60	Y2021M05	60	
Y2021M06	53	6.1	113	Y2021M06	53	-2.2	-2.1	Y2021M06	53	51	51	Y2021M06	51	
Y2021M07	53	6.0	107	Y2021M07	53	1.6	1.4	Y2021M07	53	55	55	Y2021M07	55	
Y2021M08	53	5.8	101	Y2021M08	53	-0.7	-0.6	Y2021M08	53	52	53	Y2021M08	53	
Y2021M09	54	5.6	107	Y2021M09	54	3.4	3.3	Y2021M09	54	57	57	Y2021M09	57	
Y2021M10	54	5.7	108	Y2021M10	54	1.1	1.0	Y2021M10	54	55	55	Y2021M10	55	
Y2021M11	54	5.8	107	Y2021M11	54	1.6	1.5	Y2021M11	54	56	56	Y2021M11	56	
Y2021M12	53	5.7	105	Y2021M12	53	-8.3	-7.6	Y2021M12	53	44	45	Y2021M12	45	
Y2022M01	53	5.8	112	Y2022M01	53	-1.3	-1.2	Y2022M01	53	51	51	Y2022M01	51	
Y2022M02	51	5.9	105	Y2022M02	51	-8.8	-8.8	Y2022M02	51	41	42	Y2022M02	42	
Average	52	6.0	110	Average	52	1.1	1.0	Average	52	52	52	Average	52	
Correlation	100%	29%	70%	Correlation	100%	41%	42%	Correlation	100%	41%	42%	Correlation	100%	
Accuracy				Accuracy				Accuracy		98%	98%	Accuracy		

Figure 1: Data table and calculation results of this study.

Figure 2 shows the correlations in TD among CVD risk %, eAG, and A1C over 1,303 days (from 8/8/2018 to 3/3/2022).

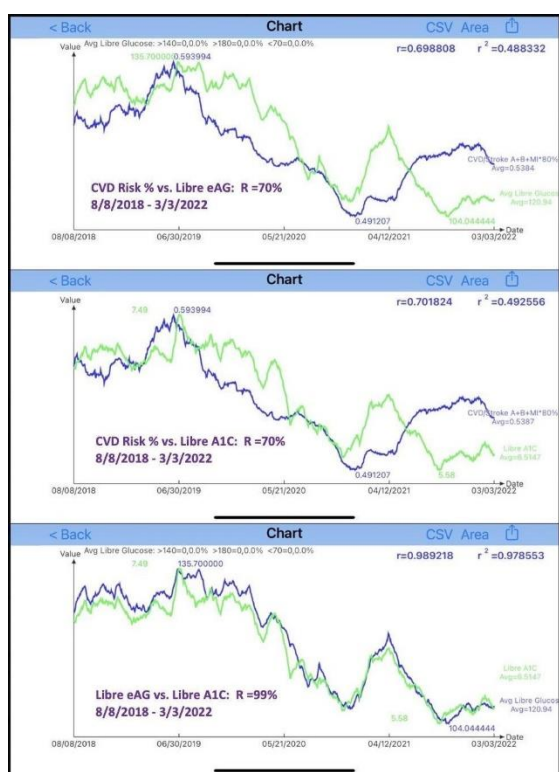

Figure 2: Correlations among CVD risk %, eAG, and A1C over 1,303 days (from 8/8/2018 to 3/3/2022).

Figure 3 depicts the correlations in TD among CVD risk %, eAG, and A1C over 15 months (516 days: from 10/1/2020 to 2/28/2022).

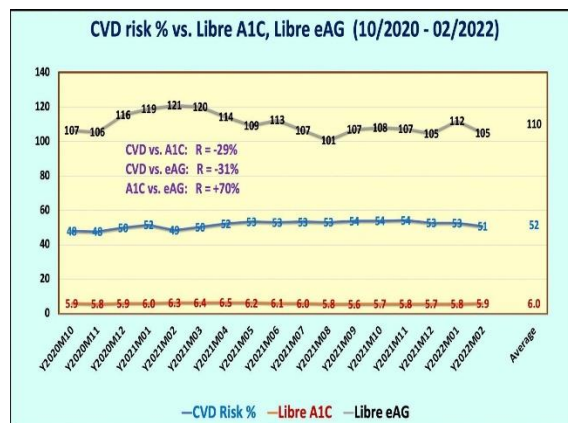

Figure 3: Correlations among CVD risk %, eAG, and A1C over 15 months (516 days: from 10/1/2020 to 2/28/2022).

Figure 4 illustrates the results of SD stress-strain diagrams of CVD risk % using eAG and A1C as its viscosity factors (η).

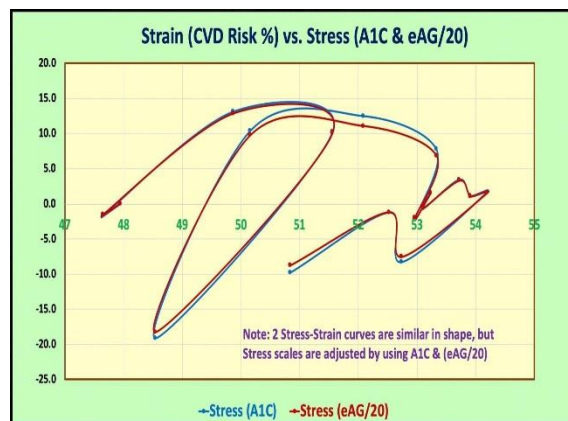

Figure 4: Viscoplastic stress-strain diagrams.

Figure 5 reflects a comparison chart between the calculated CVD risk % versus two predicted CVD risks using the viscoelastic perturbation model.

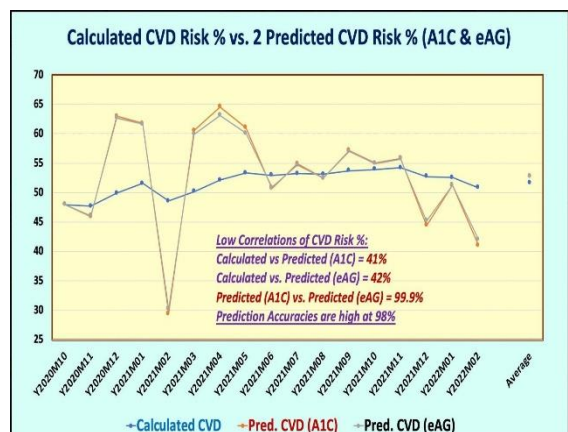

Figure 5: 2 Predicted CVD risk % versus calculated CVD risk % using visco-perturbation model.

4. CONCLUSION

In conclusion, the following four observations outline the findings from this research work:

- (1) From the time-domain (TD) waveforms, over a 15-month period from 10/1/2020 to 2/28/2022, three correlations among CVD risk, eAG, A1C are: CVD vs. eAG = -31%, CVD vs. A1C = -29%, eAG vs. A1C = 70%. These two lower negative correlations already provided a hint that this analysis

would not be able to provide useful information.

(2) However, as discussed in the Introduction section, if he selects a wider time-window of 1,303 days from 8/8/2018 to 3/3/2022, three different correlations among CVD risk, eAG, A1C are: CVD vs. eAG = 70%, CVD vs. A1C = 70%, eAG vs. A1C = 99%. If he conducts a similar analysis using this dataset, he estimates that the analysis results would be different.

(3) In the SD stress-strain diagrams, due to his modified viscosity factor (η) of eAG by multiplying a modification factor of 0.05 (or dividing by 20) on eAG, his two stress scales (Y-axis scales) are extremely close to each other; therefore, the two stress-strain curves are almost identical. In addition, the two stress-strain curves have demonstrated viscoplastic behavior.

(4) Using the viscoelastic perturbation model, a waveform comparison study of the metabolism calculated CVD risk % against two predicted CVD risks can be done. (a) Using the visco-perturbation model, the calculated CVD risk versus the predicted CVD risk based on eAG has a 42% correlation and 98% prediction accuracy. (b) Using the

visco-perturbation model, the calculated CVD risk versus the predicted CVD risk based on eAG has a 41% correlation and 98% prediction accuracy.

In summary, this analysis shows that his research based on this 15-month dataset (Figure 3) would result in unsatisfactory results. However, the CVD risk % has higher correlations with both eAG and A1C (see Figure 2). As a result, he will continue the same research work but using a different dataset with a wider time-window of collected data.

5. REFERENCES

For editing purposes, the majority of the references in this paper, which are self-references, have been removed. Only references from other authors' published sources remain. The bibliography of the author's original self-references can be viewed at www.eclairemd.com.

Readers may use this article as long as the work is properly cited, their use is educational and not for profit, and the author's original work is not altered.

Viscoelastic and Viscoplastic Glucose Theory Application in Medicine

Gerald C. Hsu

