

# The GH-Method

---

## **Viscoelastic or Viscoplastic Glucose Theory (VGT #44): Applying VGT to Study the Relationship of CGM Sensor Fasting Plasma Glucose (FPG) versus Body Temperature in Early Morning, While Using a Viscoelastic Perturbation Model to Predict FPG Values Over a 18-Month Period from 10/1/2020 to 3/7/2022 Based on the GH-Method: Math-Physical Medicine (No. 625)**

Gerald C. Hsu\*

eclairMD Foundation, USA

**Note:** Readers who want to get a quick overview can read the abstract, results, and graphs.

### **Abstract**

Since 2012, the author has been collecting his body weight (BW) and finger-piercing glucose values each day. In addition, he accumulates medical conditions data including a combination of data for blood pressure (BP) and heart rate (HR), and blood lipids along with lifestyle details of diet, exercise, sleep, stress, water intake, and daily routine details. Based on the collected big data, he further organized them into two main groups. The first group is medical conditions (MC) with 4 categories: weight, glucose, BP, and blood lipids. The second group is lifestyle details (LD) with 6 categories: food & diet, exercise, water intake, sleep, stress, and daily routines. He gathers his daily data and then calculates a unique combined score for each MC and LD with their 10 categories. The combined scores of the 2 groups, 10 categories, and 500+ elements constitute an overall “metabolism index (MI) model”. This MI model includes the root causes of 6 lifestyle inputs and 4 symptoms of the disease including the rudimentary chronic diseases: obesity, diabetes, hypertension, and hyperlipidemia. As we know, lifestyle details cause rudimentary chronic diseases which further influence more complicated diseases, such as heart problems (CVD & CHD), chronic kidney disease (CKD), stroke, diabetic retinopathy (DR), neuropathy, hypothyroidism, and others. In addition to the lifestyle-induced chronic disease and complications, environmental factors, such as radiation, air and water pollution, food poison and pollution, toxic chemicals, and hormonal therapy, can contribute to the causes for a variety of cancers. Some genetic conditions and lifetime unhealthy habits, such as smoking, alcohol consumption, illicit drug use would account for approximately 15% to 25% of the root

cause for rudimentary chronic diseases along with their complications, and cancers. All of the above-described diseases fall into the “symptoms” category which are the “root-causes” of poor and unhealthy lifestyles. In this article, the author applies the viscoelasticity and viscoplasticity theories to conduct his research to discover some hidden behavior or possible relationship among 3 key biomarkers, CVD risk (a symptom disease) probability, sensor daily average glucose (eAG), and its related sensor HbA1C (A1C). The hidden behaviors and possible inter-relationships among these three biomarkers are “time-dependent” which change from time to time. This is why he applies viscoelastic & viscoplastic theories (VGT) to conduct his recent research work. The author previously conducted similar analyses for the same sets of biomarkers using a traditional statistical regression method. Generally speaking, statistical methods only deal with numerical characteristics of collected datasets and do not connect with the internal physical characteristics of biomarkers of organs. Incidentally, the accuracy and applicability of results using any statistical method are heavily dependent on internal characteristics of the data sample, data size, and the time-window of the chosen dataset. Therefore, we must be careful in selecting appropriate statistical methods and treat their analysis conclusions cautiously. For example, in this analysis, the author has performed two basic correlation analyses of the same dataset for three biomarkers, CVD risk, eAG, and A1C, but chose two different time-windows. The following displayed results show the vast differences between the two statistical correlation analysis results: (1) Correlations using 46 months (1,303 days) from 8/8/2018 to 3/3/2022: CVD vs. eAG =

---

Received: 13 June 2022, Accepted: 23 July 2022, Available online: 26 July 2022

\*Corresponding author: Gerald C. Hsu, eclairMD Foundation, USA

70%; CVD/A1C = 70%; eAG vs. A1C = 99%. (2) Correlations using 15 months (516 days) from 10/1/2020 to 2/28/2022: CVD vs. eAG = -31%; CVD/A1C = -29%; eAG vs. A1C = 70%. One crucial point is that, in the beginning of an analysis, a quick correlation examination of two selected datasets will provide hints regarding the usefulness of the results. Obviously, a wider selected time-window usually consisting of more data elements will offer better understanding for the inner-characteristics of datasets and achieve more accurate or useful results. The following defined equations are used to establish the stress-strain diagram in a space-domain (SD): Strain =  $\epsilon$  (CVD risk %) = individual CVD risk at present time. Stress =  $\sigma$  (based on change rate of strain, CVD risk, multiplying with a viscosity factor, eAG or A1C) =  $\eta * (d\epsilon/dt) = \eta * (d\text{-strain}/d\text{-time}) =$  (viscosity factor  $\eta$  using individual eAG or A1C at present time) \* (CVD risk at present time - CVD risk at previous time). Next, he applies the viscoelastic perturbation model to calculate the following predicted CVD risk %. Perturbed or predicted CVD risk % = strain value (CVD risk) at present year + stress value at present year (i.e., CVD risk change rate \* eAG or A1C) \* amplification factor, where the selected amplification factor for A1C is 1.0 and for eAG is 0.05 (or divided by 20) which makes the two stress scales (Y-axis scales) on a more even ground. To offer a simple explanation to readers who do not have a physics or engineering background, the author includes a brief excerpt from Wikipedia regarding the description of basic concepts for elasticity and plasticity theories, viscoelasticity and viscoplasticity theories from the disciplines of engineering and physics in the method section. In conclusion, the following four observations outline the findings from this research work: (1) From the time-domain (TD) waveforms, over a 15-month

period from 10/1/2020 to 2/28/2022, three correlations among CVD risk, eAG, A1C are: CVD vs. eAG = -31%, CVD vs. A1C = -29%, eAG vs. A1C = 70%. These two lower negative correlations already provided a strong hint that this analysis would not be able to provide useful results. (2) However, as discussed in the Introduction section, if he selects a wider time-window of 1,303 days from 8/8/2018 to 3/3/2022, three different correlations among CVD risk, eAG, A1C are: CVD vs. eAG = 70%, CVD vs. A1C = 70%, eAG vs. A1C = 99%. If he conducts a similar analysis using this selected dataset, he thinks that the analysis results will be different. (3) In the SD stress-strain diagrams, due to his modified viscosity factor ( $\eta$ ) of eAG by multiplying a modification factor of 0.05 (or dividing by 20) on eAG, his two stress scales (Y-axis scales) are extremely close to each other; therefore, the two stress-strain curves are almost identical. In addition, the two stress-strain curves have demonstrated a viscoplastic behavior. (4) Using the viscoelastic perturbation model, a waveform comparison study of the metabolism calculated CVD risk % against two predicted CVD risks can be done. (a) Using the visco-perturbation model, the calculated CVD risk versus the predicted CVD risk based on eAG has a 42% correlation and 98% prediction accuracy. (b) Using the visco-perturbation model, the calculated CVD risk versus the predicted CVD risk based on A1C has a 41% correlation and 98% prediction accuracy. In summary, this analysis shows that his research using a shorter 15-month dataset (Figure 3) will result in unsatisfactory results. However, if using a longer 46-month dataset, the CVD risk % will have higher correlations with both eAG and A1C (see Figure 2). As a result, he will continue the same research work but using a different dataset with a wider time-window for the data collection.

**Keywords:** Viscoelastic; Viscoplastic; Fasting plasma glucose; Daily average glucose; HbA1C

**Abbreviations:** FPG: fasting plasma glucose; MC: medical conditions; LD: lifestyle details; MI: metabolism index; eAG: daily average glucose; SD: space-domain; TD: time-domain; MPM: math-physical medicine

## 1. INTRODUCTION

Since 2012, the author has been collecting his body weight (BW) and finger-piercing glucose values each day. In addition, he accumulates medical conditions data including a combination of data for blood pressure (BP) and heart rate (HR), and blood lipids along with lifestyle details of diet, exercise, sleep, stress, water intake, and daily routine details. Based on the collected big data, he further organized them into two main groups. The first group is medical conditions (MC) with 4 categories: weight, glucose, BP, and blood lipids. The second group is lifestyle details (LD) with 6 categories: food & diet, exercise, water intake, sleep, stress, and daily routines. He gathers his daily data and then calculates a unique combined score for each MC and LD with their 10 categories. The combined scores of the 2 groups, 10 categories, and 500+ elements constitute an overall “metabolism index (MI) model”. This MI model includes the root causes of 6 lifestyle inputs and 4 symptoms of the disease including the rudimentary chronic diseases: obesity, diabetes, hypertension, and hyperlipidemia.

As we know, lifestyle details cause rudimentary chronic diseases which further influence more complicated diseases, such as heart problems (CVD & CHD), chronic kidney disease (CKD), stroke, diabetic retinopathy (DR), neuropathy, hypothyroidism, and others. In addition to the lifestyle-induced chronic disease and complications, environmental factors, such as radiation, air and water pollution, food poison and pollution, toxic chemicals, and hormonal therapy, can contribute to the causes for a variety of cancers. Some genetic conditions and lifetime unhealthy habits, such as smoking, alcohol consumption, illicit drug use would account for approximately 15% to 25% of the root cause for rudimentary chronic diseases along with their complications, and cancers. All of the above-described diseases fall into the “symptoms” category which are the “root-causes” of poor and unhealthy lifestyles.

In this article, the author applies the viscoelasticity and viscoplasticity theories to conduct his research to discover some hidden behavior or possible relationship among 3 key

biomarkers, CVD risk (a symptom disease) probability, daily average sensor glucose (eAG), and its related sensor HbA1C (A1C). The hidden behaviors and possible inter-relationships among these three biomarkers are “time-dependent” which change from time to time. This is why he applies viscoelastic & viscoplastic theories (VGT) to conduct his recent research work.

The author previously conducted similar analyses for the same sets of biomarkers using a traditional statistical regression method. Generally speaking, statistical methods only deal with numerical characteristics of collected datasets and do not connect with the internal physical characteristics of biomarkers of organs. Incidentally, the accuracy and applicability of results using any statistical method are heavily dependent on internal characteristics of the data sample, data size, and the time-window of the chosen dataset. Therefore, we must be careful in selecting appropriate statistical methods and treat their analysis conclusions cautiously.

For example, in this analysis, the author has performed two basic correlation analyses of the same dataset for three biomarkers, CVD risk, eAG, and A1C, but chose two different time-windows. The following displayed results show the vast differences between the two statistical correlation analysis results:

(1) Correlations using 46 months (1,303 days) from 8/8/2018 to 3/3/2022: CVD vs. eAG = 70%; CVD/A1C = 70%; eAG vs. A1C = 99%

(2) Correlations using 15 months (516 days) from 10/1/2020 to 2/28/2022: CVD vs. eAG = -31%; CVD/A1C = -29%; eAG vs. A1C = 70%

One crucial point is that, in the beginning of an analysis, a quick correlation examination of two selected datasets will provide hints regarding the usefulness of the results. Obviously, a wider selected time-window usually consisting of more data elements will offer better understanding for the inner-characteristics of datasets and achieve more accurate or useful results.

The following defined equations are used to establish the stress-strain diagram in a space-domain (SD):

**Strain**

=  $\epsilon$  (CVD risk %)  
 = individual CVD risk at present time

**Stress**

=  $\sigma$  (based on change rate of strain, CVD risk, multiplying with a viscosity factor, eAG or A1C)  
 =  $\eta * (d\epsilon/dt)$   
 =  $\eta * (d\text{-strain}/d\text{-time})$   
 = (viscosity factor  $\eta$  using individual eAG or A1C at present time) \* (CVD risk at present time - CVD risk at previous time)

Next, he applies the viscoelastic perturbation model to calculate the following predicted CVD risk %.

**Perturbed or predicted CVD risk %**

= strain value (CVD risk) at present year + stress value at present year (i.e., CVD risk change rate \* eAG or A1C) \* amplification factor

Where the selected amplification factor for A1C is 1.0 and for eAG is 0.05 (or divided by 20) which makes the two stress scales (Y-axis scales) on a more even ground.

To offer a simple explanation to readers who do not have a physics or engineering background, the author includes a brief excerpt from Wikipedia regarding the description of basic concepts for elasticity and plasticity theories, viscoelasticity and viscoplasticity theories from the disciplines of engineering and physics in the method section.

**2. METHODS**

**2.1 Elasticity, plasticity, viscoelasticity and viscoplasticity**

The difference between elastic materials and viscoelastic materials (from “Soborthans, innovating shock and vibration solutions”).

**What are elastic materials?**

Elasticity is the tendency of solid materials to return to their original shape after forces are applied on them. When the forces are removed, the object will return to its initial shape and size if the material is elastic.

**What are viscous materials?**

Viscosity is a measure of a fluid’s resistance to flow. A fluid with large viscosity resists motion. A fluid with low viscosity flows. For example, water flows more easily than syrup because it has a lower viscosity. High viscosity materials might include honey, syrups, or gels – generally things that resist flow. Water is a low viscosity material, as it flows readily. Viscous materials are thick or sticky or adhesive. Since heating reduces viscosity, these materials don’t flow easily. For example, warm syrup flows more easily than cold.

**What is viscoelastic?**

Viscoelasticity is the property of materials that exhibit both viscous and elastic characteristics when undergoing deformation. Synthetic polymers, wood, and human tissue, as well as metals at high temperature, display significant viscoelastic effects. In some applications, even a small viscoelastic response can be significant.

**Elastic behavior versus viscoelastic behavior**

The difference between elastic materials and viscoelastic materials is that viscoelastic materials have a viscosity factor and the elastic ones don’t. Because viscoelastic materials have the viscosity factor, they have a strain rate dependent on time. Purely elastic materials do not dissipate energy (heat) when a load is applied, then removed; however, a viscoelastic substance does.

The following brief introductions are excerpts from Wikipedia:

**“Elasticity (physics):**

The physical property when materials or objects return to original shape after deformation.

In physics and materials science, elasticity is the ability of a body to resist a distorting influence and to return to its original size and shape when that influence or force is removed. Solid objects will deform when adequate loads are applied to them; if the material is elastic, the object will return to its initial shape and size after removal. This is in contrast to plasticity, in which the object

fails to do so and instead remains in its deformed state.

The physical reasons for elastic behavior can be quite different for different materials. In metals, the atomic lattice changes size and shape when forces are applied (energy is added to the system). When forces are removed, the lattice goes back to the original lower energy state. For rubbers and other polymers, elasticity is caused by the stretching of polymer chains when forces are applied.

Hooke's law states that the force required to deform elastic objects should be directly proportional to the distance of deformation, regardless of how large that distance becomes. This is known as perfect elasticity, in which a given object will return to its original shape no matter how strongly it is deformed. This is an ideal concept only; most materials which possess elasticity in practice remain purely elastic only up to very small deformations, after which plastic (permanent) deformation occurs.

In engineering, the elasticity of a material is quantified by the elastic modulus such as the Young's modulus, bulk modulus or shear modulus which measure the amount of stress needed to achieve a unit of strain; a higher modulus indicates that the material is harder to deform. The material's elastic limit or yield strength is the maximum stress that can arise before the onset of plastic deformation.

Plasticity (physics):

Deformation of a solid material undergoing non-reversible changes of shape in response to applied forces.

In physics and materials science, plasticity, also known as plastic deformation, is the ability of a solid material to undergo permanent deformation, a non-reversible change of shape in response to applied forces. For example, a solid piece of metal being bent or pounded into a new shape displays plasticity as permanent changes occur within the material itself. In engineering, the transition from elastic behavior to plastic behavior is known as yielding.

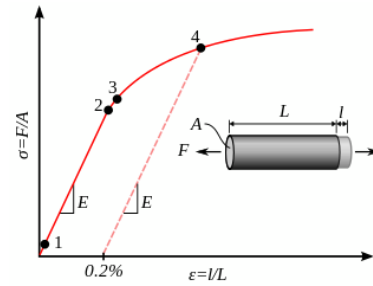

Stress–strain curve showing typical yield behavior for nonferrous alloys.

1. True elastic limit
2. Proportionality limit
3. Elastic limit
4. Offset yield strength

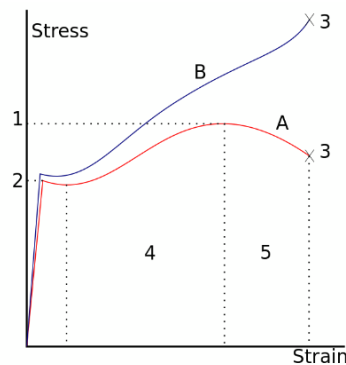

A stress–strain curve typical of structural steel.

- 1: Ultimate strength
- 2: Yield strength (yield point)
- 3: Rupture
- 4: Strain hardening region
- 5: Necking region
- A: Apparent stress ( $F/A_0$ )
- B: Actual stress ( $F/A$ )

Plastic deformation is observed in most materials, particularly metals, soils, rocks, concrete, and foams. However, the physical mechanisms that cause plastic deformation can vary widely. At a crystalline scale, plasticity in metals is usually a consequence of dislocations. Such defects are relatively rare in most crystalline materials, but are numerous in some and part of their crystal structure; in such cases, plastic crystallinity can result. In brittle materials such as rock, concrete and bone, plasticity is caused predominantly by slip at microcracks. In cellular materials such as liquid foams or biological tissues, plasticity is mainly a

consequence of bubble or cell rearrangements, notably T1 processes.

For many ductile metals, tensile loading applied to a sample will cause it to behave in an elastic manner. Each increment of load is accompanied by a proportional increment in extension. When the load is removed, the piece returns to its original size. However, once the load exceeds a threshold – the yield strength – the extension increases more rapidly than in the elastic region; now when the load is removed, some degree of extension will remain.

Elastic deformation, however, is an approximation and its quality depends on the time frame considered and loading speed. If, as indicated in the graph opposite, the deformation includes elastic deformation, it is also often referred to as "elasto-plastic deformation" or "elastic-plastic deformation".

Perfect plasticity is a property of materials to undergo irreversible deformation without any increase in stresses or loads. Plastic materials that have been hardened by prior deformation, such as cold forming, may need increasingly higher stresses to deform further. Generally, plastic deformation is also dependent on the deformation speed, i.e. higher stresses usually have to be applied to increase the rate of deformation. Such materials are said to deform viscoplastically.”

Viscoelasticity:

Property of materials with both viscous and elastic characteristics under deformation.

In materials science and continuum mechanics, viscoelasticity is the property of materials that exhibit both viscous and elastic characteristics when undergoing deformation. Viscous materials, like water, resist shear flow and strain linearly with time when a stress is applied. Elastic materials strain when stretched and immediately return to their original state once the stress is removed.

Viscoelastic materials have elements of both of these properties and, as such, exhibit time-dependent strain. Whereas elasticity is usually the result of bond stretching along crystallographic planes in an ordered solid,

viscosity is the result of the diffusion of atoms or molecules inside an amorphous material.

In the nineteenth century, physicists such as Maxwell, Boltzmann, and Kelvin researched and experimented with creep and recovery of glasses, metals, and rubbers. Viscoelasticity was further examined in the late twentieth century when synthetic polymers were engineered and used in a variety of applications. Viscoelasticity calculations depend heavily on the viscosity variable,  $\eta$ . The inverse of  $\eta$  is also known as fluidity,  $\phi$ . The value of either can be derived as a function of temperature or as a given value (i.e., for a dashpot).

Depending on the change of strain rate versus stress inside a material, the viscosity can be categorized as having a linear, non-linear, or plastic response. When a material exhibits a linear response, it is categorized as a Newtonian material. In this case the stress is linearly proportional to the strain rate. If the material exhibits a non-linear response to the strain rate, it is categorized as non-Newtonian fluid. There is also an interesting case where the viscosity decreases as the shear/strain rate remains constant. A material which exhibits this type of behavior is known as thixotropic. In addition, when the stress is independent of this strain rate, the material exhibits plastic deformation. Many viscoelastic materials exhibit rubber like behavior explained by the thermodynamic theory of polymer elasticity.

Cracking occurs when the strain is applied quickly and outside of the elastic limit. Ligaments and tendons are viscoelastic, so the extent of the potential damage to them depends both on the rate of the change of their length as well as on the force applied.

A viscoelastic material has the following properties:

- hysteresis is seen in the stress–strain curve
- stress relaxation occurs: step constant strain causes decreasing stress
- creep occurs: step constant stress causes increasing strain
- its stiffness depends on the strain rate or the stress rate.

Elastic versus viscoelastic behavior

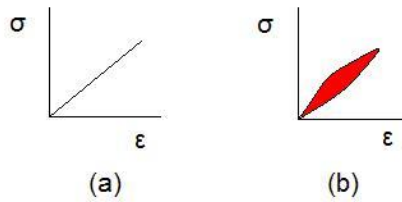

Stress–strain curves for a purely elastic material (a) and a viscoelastic material (b). The red area is a hysteresis loop and shows the amount of energy lost (as heat) in a loading and unloading cycle. It is equal to

$$\oint \sigma d\epsilon$$

where  $\sigma$  is stress and  $\epsilon$  is strain.

Unlike purely elastic substances, a viscoelastic substance has an elastic component and a viscous component. The viscosity of a viscoelastic substance gives the substance a strain rate dependence on time. Purely elastic materials do not dissipate energy (heat) when a load is applied, then removed. However, a viscoelastic substance dissipates energy when a load is applied, then removed. Hysteresis is observed in the stress–strain curve, with the area of the loop being equal to the energy lost during the loading cycle. Since viscosity is the resistance to thermally activated plastic deformation, a viscous material will lose energy through a loading cycle. Plastic deformation results in lost energy, which is uncharacteristic of a purely elastic material's reaction to a loading cycle.

Specifically, viscoelasticity is a molecular rearrangement. When a stress is applied to a viscoelastic material such as a polymer, parts of the long polymer chain change positions. This movement or rearrangement is called “creep”. Polymers remain a solid material even when these parts of their chains are rearranging in order to accompany the stress, and as this occurs, it creates a back stress in the material. When the back stress is the same magnitude as the applied stress, the material no longer creeps. When the original stress is taken away, the accumulated back stresses will cause the polymer to return to its original form. The material creeps, which gives the prefix visco-, and the material fully recovers, which gives the suffix -elasticity.

Viscoplasticity:

Viscoplasticity is a theory in continuum mechanics that describes the rate-dependent inelastic behavior of solids. Rate-dependence in this context means that the deformation of the material depends on the rate at which loads are applied. The inelastic behavior that is the subject of viscoplasticity is plastic deformation which means that the material undergoes unrecoverable deformations when a load level is reached. Rate-dependent plasticity is important for transient plasticity calculations. The main difference between rate-independent plastic and viscoplastic material models is that the latter exhibit not only permanent deformations after the application of loads but continue to undergo a creep flow as a function of time under the influence of the applied load.

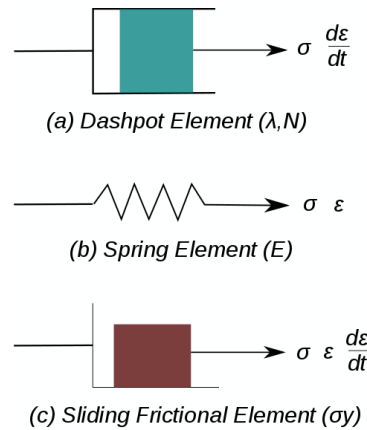

Figure 1. Elements used in one-dimensional models of viscoplastic materials.

The elastic response of viscoplastic materials can be represented in one-dimension by Hookean spring elements. Rate-dependence can be represented by nonlinear dashpot elements in a manner similar to viscoelasticity. Plasticity can be accounted for by adding sliding frictional elements as shown in Figure 1. In the figure E is the modulus of elasticity,  $\lambda$  is the viscosity parameter and N is a power-law type parameter that represents non-linear dashpot [ $\sigma(d\epsilon/dt) = \sigma = \lambda(d\epsilon/dt)^{1/N}$ ]. The sliding element can have a yield stress ( $\sigma_y$ ) that is strain rate dependent, or even constant, as shown in Figure 1c.

Viscoplasticity is usually modeled in three-dimensions using overstress models of the Perzyna or Duvaut-Lions types. In these

models, the stress is allowed to increase beyond the rate-independent yield surface upon application of a load and then allowed to relax back to the yield surface over time. The yield surface is usually assumed not to be rate-dependent in such models. An alternative approach is to add a strain rate dependence to the yield stress and use the techniques of rate independent plasticity to calculate the response of a material.

For metals and alloys, viscoplasticity is the macroscopic behavior caused by a mechanism linked to the movement of dislocations in grains, with superposed effects of inter-crystalline gliding. The mechanism usually becomes dominant at temperatures greater than approximately one third of the absolute melting temperature. However, certain alloys exhibit viscoplasticity at room temperature (300K). For polymers, wood, and bitumen, the theory of viscoplasticity is required to describe behavior beyond the limit of elasticity or viscoelasticity.

In general, viscoplasticity theories are useful in areas such as

- the calculation of permanent deformations,
- the prediction of the plastic collapse of structures,
- the investigation of stability,
- crash simulations,
- systems exposed to high temperatures such as turbines in engines, e.g. a power plant,
- dynamic problems and systems exposed to high strain rates.

### Phenomenology

For a qualitative analysis, several characteristic tests are performed to describe the phenomenology of viscoplastic materials. Some examples of these tests are

1. hardening tests at constant stress or strain rate,
2. creep tests at constant force, and
3. stress relaxation at constant elongation.

### Strain hardening test

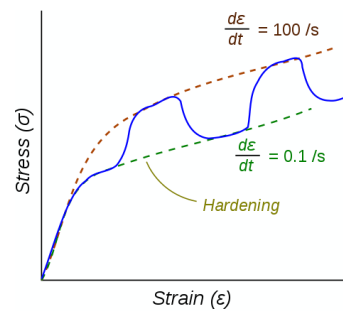

Figure 2. Stress–strain response of a viscoplastic material at different strain rates.

The dotted lines show the response if the strain-rate is held constant. The blue line shows the response when the strain rate is changed suddenly.

One consequence of yielding is that as plastic deformation proceeds, an increase in stress is required to produce additional strain. This phenomenon is known as Strain/Work hardening. For a viscoplastic material the hardening curves are not significantly different from those of rate-independent plastic material. Nevertheless, three essential differences can be observed.

1. At the same strain, the higher the rate of strain the higher the stress.
2. A change in the rate of strain during the test results in an immediate change in the stress–strain curve.
3. The concept of a plastic yield limit is no longer strictly applicable.

The hypothesis of partitioning the strains by decoupling the elastic and plastic parts is still applicable where the strains are small, i.e.,

$$\varepsilon = \varepsilon_e + \varepsilon_{vp}$$

where  $\varepsilon_e$  is the elastic strain and  $\varepsilon_{vp}$  is the viscoplastic strain.

To obtain the stress–strain behavior shown in blue in the figure, the material is initially loaded at a strain rate of 0.1/s. The strain rate is then instantaneously raised to 100/s and held constant at that value for some time. At the end of that time period the strain rate is dropped instantaneously back to 0.1/s and the cycle is continued for increasing values of strain. There is clearly a lag between the strain-rate change and the stress response.

This lag is modeled quite accurately by overstress models (such as the Perzyna model) but not by models of rate-independent plasticity that have a rate-dependent yield stress.”

**Note:** For a more detailed description, please refer to the “consolidated method” section which is given at the beginning of the special issue.

### 3. RESULTS

Figure 1 displays the data table and calculated results of this study.

11/20/20	7	11	12	11/25/21	Strain	Stress 1	Stress 2	11/25/21	Strain (C/D)	Strain (C/D)	Strain (C/D)
Period	CVD Risk %	Libre A1C	Libre eAG	Period	Strain (A/G)	Stress (A/G)	Stress (A/G/20)	Period	Calculated CVD	Pred. CVD (A1C)	Pred. CVD (eAG)
11/20/20	48	5.9	107	11/20/20	48	6.0	3.0	11/20/20	48	48	48
11/20/21	48	5.8	106	11/20/21	48	-1.7	-1.6	11/20/21	48	46	46
11/20/22	50	5.9	116	11/20/22	50	13.1	12.8	11/20/22	50	62	62
11/21/01	52	6.0	119	11/21/01	52	18.2	18.1	11/21/01	52	62	62
11/21/02	48	6.3	121	11/21/02	48	-18.1	-18.3	11/21/02	48	29	30
11/21/03	50	6.4	120	11/21/03	50	18.4	17	11/21/03	50	61	60
11/21/04	52	6.5	114	11/21/04	52	12.4	11.8	11/21/04	52	65	62
11/21/05	53	6.2	109	11/21/05	53	7.7	6.8	11/21/05	53	61	60
11/21/06	53	6.1	113	11/21/06	53	-2.2	-2.1	11/21/06	53	51	51
11/21/07	53	6.0	107	11/21/07	53	1.6	1.4	11/21/07	53	55	55
11/21/08	53	5.8	101	11/21/08	53	-0.7	-0.6	11/21/08	53	52	52
11/21/09	54	5.6	107	11/21/09	54	3.4	3.3	11/21/09	54	57	57
11/21/10	54	5.7	106	11/21/10	54	1.1	1.0	11/21/10	54	55	55
11/21/11	54	5.8	107	11/21/11	54	1.6	1.5	11/21/11	54	56	56
11/21/12	53	5.7	105	11/21/12	53	-4.3	-3.6	11/21/12	53	44	45
11/22/01	53	5.8	112	11/22/01	53	-1.3	-1.2	11/22/01	53	51	51
11/22/02	51	5.9	105	11/22/02	51	-4.8	-4.8	11/22/02	51	41	42
Average	52	6.0	110	Average	52	1.1	1.0	Average	52.7	51.7	52.7
Correlation	100%	-29%	-31%					Correlation	100%	41%	42%
Correlation			70%					Accuracy		98%	98%

Figure 1: Data table and calculation results of this study.

Figure 2 shows the correlations in TD among CVD risk %, eAG, and A1C over 1,303 days (from 8/8/2018 to 3/3/2022).

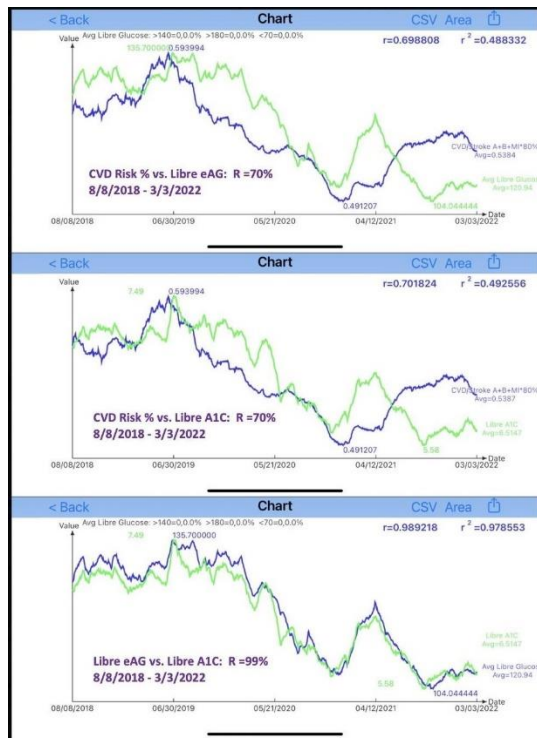

Figure 2: Correlations among CVD risk %, eAG, and A1C over 1,303 days (from 8/8/2018 to 3/3/2022).

Figure 3 depicts the correlations in TD among CVD risk %, eAG, and A1C over 15 months (516 days: from 10/1/2020 to 2/28/2022).

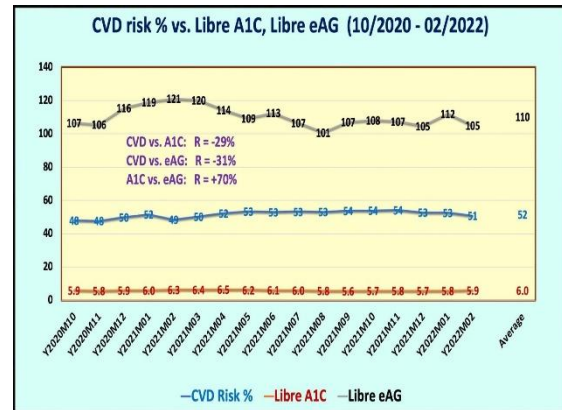

Figure 3: Correlations among CVD risk %, eAG, and A1C over 15 months (516 days: from 10/1/2020 to 2/28/2022).

Figure 4 reflects the results of SD stress-strain diagrams of CVD risk % using eAG and A1C as its viscosity factors ( $\eta$ ).

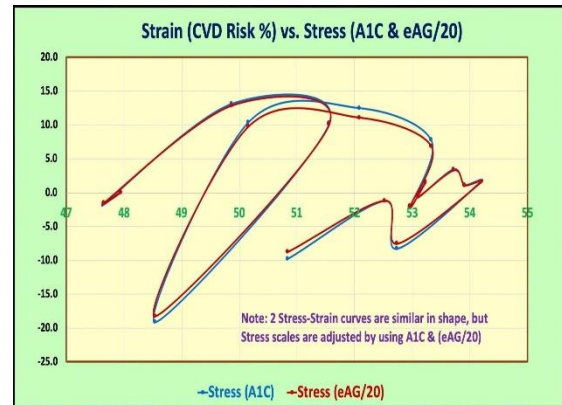

Figure 4: Viscoplastic stress-strain diagrams.

Figure 5 illustrates a comparison chart between the calculated CVD risk % versus two predicted CVD risks using a viscoelastic perturbation model.

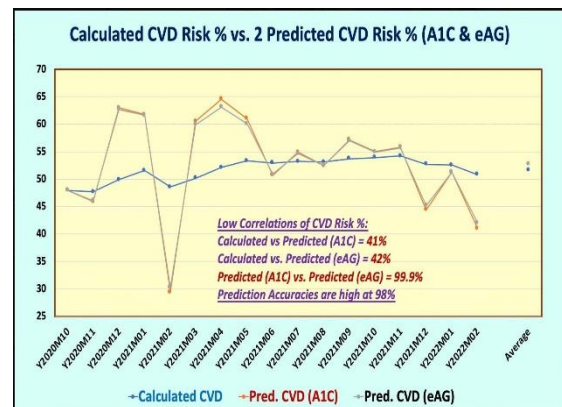

Figure 5: 2 Predicted CVD risk % versus calculated CVD risk % using a visco-perturbation model.

## 4. CONCLUSION

In conclusion, the following four observations outline the findings from this research work:

(1) From the time-domain (TD) waveforms, over a 15-month period from 10/1/2020 to 2/28/2022, three correlations among CVD risk, eAG, A1C are: CVD vs. eAG = -31%, CVD vs. A1C = -29%, eAG vs. A1C = 70%. These two lower negative correlations already provided a strong hint that this analysis would not be able to provide useful results.

(2) However, as discussed in the Introduction section, if he selects a wider time-window of 1,303 days from 8/8/2018 to 3/3/2022, three different correlations among CVD risk, eAG, A1C are: CVD vs. eAG = 70%, CVD vs. A1C = 70%, eAG vs. A1C = 99%. If he conducts a similar analysis using this selected dataset, he thinks that the analysis results will be different.

(3) In the SD stress-strain diagrams, due to his modified viscosity factor ( $\eta$ ) of eAG by multiplying a modification factor of 0.05 (or dividing by 20) on eAG, his two stress scales (Y-axis scales) are extremely close to each other; therefore, the two stress-strain curves are almost identical. In addition, the two stress-strain curves have demonstrated a viscoplastic behavior.

(4) Using the viscoelastic perturbation model, a waveform comparison study of the

metabolism calculated CVD risk % against two predicted CVD risks can be done. (a) Using the visco-perturbation model, the calculated CVD risk versus the predicted CVD risk based on eAG has a 42% correlation and 98% prediction accuracy. (b) Using the visco-perturbation model, the calculated CVD risk versus the predicted CVD risk based on A1C has a 41% correlation and 98% prediction accuracy.

In summary, this analysis shows that his research using a shorter 15-month dataset (Figure 3) will result in unsatisfactory results. However, if using a longer 46-month dataset, the CVD risk % will have higher correlations with both eAG and A1C (see Figure 2). As a result, he will continue the same research work but using a different dataset with a wider time-window for the data collection.

## 5. REFERENCES

For editing purposes, the majority of the references in this paper, which are self-references, have been removed. Only references from other authors' published sources remain. The bibliography of the author's original self-references can be viewed at [www.eclaircmd.com](http://www.eclaircmd.com).

Readers may use this article as long as the work is properly cited, their use is educational and not for profit, and the author's original work is not altered.

# Viscoelastic and Viscoplastic Glucose Theory Application in Medicine

Gerald C. Hsu

