

The GH-Method

Viscoelastic or Viscoplastic Glucose Theory (VGT #54): Estimating Relative Energy Carried by Glucose Under the Influence of Body Weight While Using the Collected Data from the Daily Estimated Average Glucose and Body Weight in the Early Morning Over Three Triple-Year Periods, Y2013-Y2015, Y2016-Y2018, and Y2019-Y2021, Along with the Application of a VGT Tool and Frequency Domain Energy Method Based on GH-Method: Math-Physical Medicine (No. 642)

Gerald C. Hsu*

eclaireMD Foundation, USA

Note: Readers who want to get a quick overview can read the abstract, results, and graphs.

Abstract

The author was a professional engineer working in the fields of the space shuttle, naval battleships, nuclear power plants, computer hardware and software, artificial intelligence, and semiconductor chips. After retiring from his work, he started to self-study and research internal medicine with an emphasis on the exploration of various biomarker relationships and the prevention of metabolic disorder-induced chronic diseases. Since 2010, he utilized the disciplines learned from 7 different universities along with various work experiences to formulate his current medical research work during the past 13 years. One thing he discovered in engineering and medicine, we frequently seek answers, illustrations, or explanations for the relationships between the input variable (force applied on a structure or cause of a disease) and output variable (deformation of a structure or symptom of a disease). However, the multiple relationships between input and output could be expressed with many different matrix formats of 1×1 , $1 \times n$, $m \times 1$, or $m \times n$ (m or n means different multiple variables). In addition to these described mathematical complications, the output resulting from one or more inputs can also become an input of another output, i.e. a symptom of certain causes can become a cause of another different symptom. This phenomenon is a complex scenario with "chain effects". Engineering and biomedical complications are fundamentally mathematical problems that correlate or conform with many inherent physical laws or principles. Over the past 13 years, in his medical research work, he has

encountered more than 100 different sets of biomarkers with almost equal amounts of cause/input variables versus symptom/output variables. For example, food and exercise influence both body weight and glucose level, where persistent high glucose can result in diabetes. When diabetes combines with hypertension (high blood pressure) and hyperlipidemia (high blood lipids), it can cause cardiovascular diseases. Furthermore, obesity and diabetes are also linked with various kinds of cancers. These multiple sets of biomedical input versus output have been researched by the author using different tools he has learned from academic fields of mathematics, physics, computer science, and engineering. For example, he has applied a signal processing technique to separate 19 components from the combined postprandial plasma glucose (PPG) wave. He identified the carbs/sugar intake amount and post-meal exercise as the two most important contributing factors to PPG formation. Based on these findings, he then applied the theory of elasticity to develop a linear elastic glucose theory (LEGT) to predict PPG value with high prediction accuracy, using fasting plasma glucose (FPG), carbs/sugar grams, and post-meal walking k -steps as three major input components of predicted PPG formation. Furthermore, he selected a specific PPG waveform in the time domain (TD) and applied Fourier transform technique to convert it into a waveform in the frequency domain (FD). The y -axis value in the frequency diagram indicates the magnitude of energy corresponding to a certain frequency component on the x -axis, while the total area

underneath the frequency-energy curve is the total relative energy associated with the specific PPG wave. He calls this relative energy the “frequency energy”. Recently, he has applied theories of viscoelasticity and viscoplasticity (VGT) in physics and engineering to various biomedical problems and has written more than 50 biomedical research papers. This VGT technique emphasizes the time-dependency characteristics of certain variables. In the medical field, most biomarkers are time-dependent since body organ cells are organic in nature and change all of the time. Incidentally, VGT can generate a stress-strain curve or cause-symptom curve (in physics, it is called the “hysteresis loop”), in which area size can be used to estimate the relative energy created during the uploading (digesting carbs/sugar) and unloading (walking exercise) process over the timespan of a PPG wave. He calls this relative energy the “VGT energy”. In this article, he selects 9-years of the collected data and groups them into 3 triple-year periods: Y2013-Y2015, Y2016-Y2018, and Y2019-Y2021. Within each period, he further assembles them into 36 months. This selected dataset contains 2 key biomarkers, daily estimated average glucose (eAG) as the symptom (output) and body weight (BW) in the early morning as the causes (inputs) to conduct his VGT analysis. Now, he can apply VGT specifically to construct a stress-strain diagram with a hysteresis loop area that corresponds to the energy status from the input variable of BW. In this study, he has chosen 170 lbs. (BMI 25 for his case) to normalize all of the collected BW data. The purpose is to determine the amount of relative energy level for his eAG in each period via both frequency energy and VGT energy. The following defined stress and strain equations are used to establish the VGT stress-strain diagram in a space domain (SD): VGT strain = ε (symptom) = individual symptom at the present time. VGT stress = σ (based on the change rate of strain, symptom, multiplying with one or more viscosity factors or causes) = $\eta * (d\varepsilon/dt) = \eta * (d\text{-strain}/d\text{-time}) = (\text{viscosity factor } \eta \text{ using normalized cause at present time}) * (\text{symptom at present time} - \text{symptom at a previous time})$, where the strain is his eAG value and the stress is the eAG change rate multiplied by his normalized body weight (BW/170) as the viscosity factor. To offer a simple explanation to readers who do not have a physics or engineering background, the author includes a brief excerpt from Wikipedia regarding the description of basic concepts for elasticity and plasticity theories, viscoelasticity, and viscoplasticity theories from the disciplines of engineering and physics in the method section. In conclusion, the following five described biophysical observations have demonstrated the main characteristics and behaviors of both

viscoelasticity and viscoplasticity, VGT energy, and frequency energy estimation via fast Fourier transformation: (1) When body weight drops continuously over the 3 triple-year periods, his eAG also decreases accordingly. This eAG reduction can be seen clearly from the three scales of strain, i.e. x-axis scales. See the data of (BW, eAG): Y13-15 = (178 lbs., 132 mg/dL); Y16-18 = (173 lbs., 118 mg/dL); Y19-21 = (170 lbs., 108 mg/dL). (2) From the 3 eAG waveforms in TD, the 180-days moving average curve shapes are different from one another which indicates that the 3 strain rates or eAG change rates of the 3 triple-year periods vary as well. (3) The three-body weights over the 3 triple-year periods are continuously dropping when time moves forward. This phenomenon provides a clue that the viscosity factor, i.e. η or body weight, is decreasing as time moves forward. Therefore, the stress magnitude is declining from the earlier period to the recent period since stress is the strain rate multiplied by the viscosity factor of body weight. Please note that the body weights used as the viscosity factors are divided by 170 lbs. (BMI of 25.0). See the continuously decreasing stress range or x-axis scale: Y13-15 = (-25 to 25); Y16-18 = (-15 to 15); Y19-21 = (-8 to 8). (4) The calculated hysteresis loop area is continuously reducing from earlier period to recent period since the loop area is the summation of all trapezoid sub-areas of the stress-strain curve for each triple-year period. From a mathematical viewpoint, this makes perfect sense when the strain and stress are on a downward sliding scale, their loop areas follow the same path. The three-loop areas represent the associated relative energy of eAG under the influence of body weight within each period. See the relative energy associated with three different hysteresis loop areas: Y13-15 = 662; Y16-18 = 330; Y19-21 = 138. (5) Using the Fourier Transform technique to convert the eAG wave from a time domain into a frequency domain, the total area underneath the frequency curve of each period also indicates the associated relative energy of the corresponding eAG in each period. See the frequency energy areas: Y13-15 = 306,281; Y16-18 = 112,798; Y19-21 = 104,486. In summary, body weight influences glucose. The energy in glucose circulates with the blood flow inside the body. If we have excessive energy within the blood flow, it can damage internal organs and cause various types of complications. From this study, the 9-year biomarker data are further grouped into three identical triple-year sub-periods. Here is the energy ratio for every 3 periods as follows: (1) Energy ratio using VGT method: 100%, 50%, and 21%; (2) Energy ratio using Frequency method: 100%, 37%, and 34%. These two energy ratios have similar patterns of continuous reduction when his body weight and glucose conditions improve.

Keywords: Viscoelastic; Viscoplastic; Body weight; Fasting plasma glucose; Postprandial plasma glucose

Abbreviations: LEGT: linear elastic glucose theory; PPG: postprandial plasma glucose; FPG: fasting plasma glucose; TD: time domain; FD: frequency domain; SD: space domain; MPM: math-physical medicine

1. INTRODUCTION

The author was a professional engineer working in the fields of the space shuttle, naval battleships, nuclear power plants, computer hardware and software, artificial intelligence, and semiconductor chips. After retiring from his work, he started to self-study and research internal medicine with an emphasis on the exploration of various biomarker relationships and the prevention of metabolic disorder-induced chronic diseases. Since 2010, he utilized the disciplines learned from 7 different universities along with various work experiences to formulate his current medical research work during the past 13 years.

One thing he discovered in engineering and medicine, we frequently seek answers, illustrations, or explanations for the relationships between the input variable (force applied on a structure or cause of a disease) and output variable (deformation of a structure or symptom of a disease). However, the multiple relationships between input and output could be expressed with many different matrix formats of 1×1 , $1 \times n$, $m \times 1$, or $m \times n$ (m or n means different multiple variables). In addition to these described mathematical complications, the output resulting from one or more inputs can also become an input of another output, i.e. a symptom of certain causes can become a cause of another different symptom. This phenomenon is a complex scenario with “chain effects”. Engineering and biomedical complications are fundamentally mathematical problems that correlate or conform with many inherent physical laws or principles.

Over the past 13 years, in his medical research work, he has encountered more than 100 different sets of biomarkers with almost equal amounts of cause/input variables versus symptom/output variables. For example, food and exercise influence both body weight and glucose level, where persistent high glucose can result in diabetes. When diabetes combines with hypertension (high blood pressure) and hyperlipidemia (high blood lipids), it can cause cardiovascular diseases. Furthermore, obesity and diabetes are also linked with various kinds of cancers. These multiple sets

of biomedical input versus output have been researched by the author using different tools he has learned from academic fields of mathematics, physics, computer science, and engineering.

For example, he has applied a signal processing technique to separate 19 components from the combined postprandial plasma glucose (PPG) wave. He identified the carbs/sugar intake amount and post-meal exercise as the two most important contributing factors to PPG formation. Based on these findings, he then applied the theory of elasticity to develop a linear elastic glucose theory (LEGT) to predict PPG value with high prediction accuracy, using fasting plasma glucose (FPG), carbs/sugar grams, and post-meal walking k -steps as three major input components of predicted PPG formation.

Furthermore, he selected a specific PPG waveform in the time domain (TD) and applied Fourier transform technique to convert it into a waveform in the frequency domain (FD). The y -axis value in the frequency diagram indicates the magnitude of energy corresponding to a certain frequency component on the x -axis, while the total area underneath the frequency-energy curve is the total relative energy associated with the specific PPG wave. He calls this relative energy the “frequency energy”.

Recently, he has applied theories of viscoelasticity and viscoplasticity (VGT) in physics and engineering to various biomedical problems and has written more than 50 biomedical research papers. This VGT technique emphasizes the time-dependency characteristics of certain variables. In the medical field, most biomarkers are time-dependent since body organ cells are organic in nature and change all of the time. Incidentally, VGT can generate a stress-strain curve or cause-symptom curve (in physics, it is called the “hysteresis loop”), in which area size can be used to estimate the relative energy created during the uploading (digesting carbs/sugar) and unloading (walking exercise) process over the timespan of a PPG wave. He calls this relative energy the “VGT energy”.

In this article, he selects 9-years of the collected data and groups them into 3 triple-

year periods: Y2013-Y2015, Y2016-Y2018, and Y2019-Y2021. Within each period, he further assembles them into 36 months. This selected dataset contains 2 key biomarkers, daily estimated average glucose (eAG) as the symptom (output) and body weight (BW) in the early morning as the causes (inputs) to conduct his VGT analysis. Now, he can apply VGT specifically to construct a stress-strain diagram with a hysteresis loop area that corresponds to the energy status from the input variable of BW. In this study, he has chosen 170 lbs. (BMI 25 for his case) to normalize all of the collected BW data. The purpose is to determine the amount of relative energy level for his eAG in each period via both frequency energy and VGT energy.

The following defined stress and strain equations are used to establish the VGT stress-strain diagram in a space domain (SD):

VGT strain
 = ϵ (symptom)
 = individual symptom at the present time

VGT stress
 = σ (based on the change rate of strain, symptom, multiplying with one or more viscosity factors or causes)
 = $\eta * (de/dt)$
 = $\eta * (d\text{-strain}/d\text{-time})$
 = (viscosity factor η using normalized cause at present time) * (symptom at present time - symptom at a previous time)

Where the strain is his eAG value and the stress is the eAG change rate multiplied by his normalized body weight (BW/170) as the viscosity factor.

To offer a simple explanation to readers who do not have a physics or engineering background, the author includes a brief excerpt from Wikipedia regarding the description of basic concepts for elasticity and plasticity theories, viscoelasticity, and viscoplasticity theories from the disciplines of engineering and physics in the method section.

2. METHODS

2.1 Elasticity, plasticity, viscoelasticity, and viscoplasticity

The difference between elastic materials and viscoelastic materials (from “Soborthans, innovating shock and vibration solutions”).

What are elastic materials?

Elasticity is the tendency of solid materials to return to their original shape after forces are applied on them. When the forces are removed, the object will return to its initial shape and size if the material is elastic.

What are viscous materials?

Viscosity is a measure of a fluid’s resistance to flow. A fluid with large viscosity resists motion. A fluid with low viscosity flows. For example, water flows more easily than syrup because it has a lower viscosity. High viscosity materials might include honey, syrups, or gels – generally things that resist flow. Water is a low viscosity material, as it flows readily. Viscous materials are thick or sticky or adhesive. Since heating reduces viscosity, these materials don’t flow easily. For example, warm syrup flows more easily than cold.

What is viscoelastic?

Viscoelasticity is the property of materials that exhibit both viscous and elastic characteristics when undergoing deformation. Synthetic polymers, wood, and human tissue, as well as metals at high temperature, display significant viscoelastic effects. In some applications, even a small viscoelastic response can be significant.

Elastic behavior versus viscoelastic behavior

The difference between elastic materials and viscoelastic materials is that viscoelastic materials have a viscosity factor and the elastic ones don’t. Because viscoelastic materials have the viscosity factor, they have a strain rate dependent on time. Purely elastic materials do not dissipate energy (heat) when a load is applied, then removed; however, a viscoelastic substance does.

The following brief introductions are excerpts from Wikipedia:

“Elasticity (physics):

The physical property when materials or objects return to original shape after deformation.

In physics and materials science, elasticity is the ability of a body to resist a distorting influence and to return to its original size and shape when that influence or force is removed. Solid objects will deform when adequate loads are applied to them; if the material is elastic, the object will return to its initial shape and size after removal. This is in contrast to plasticity, in which the object fails to do so and instead remains in its deformed state.

The physical reasons for elastic behavior can be quite different for different materials. In metals, the atomic lattice changes size and shape when forces are applied (energy is added to the system). When forces are removed, the lattice goes back to the original lower energy state. For rubbers and other polymers, elasticity is caused by the stretching of polymer chains when forces are applied.

Hooke's law states that the force required to deform elastic objects should be directly proportional to the distance of deformation, regardless of how large that distance becomes. This is known as perfect elasticity, in which a given object will return to its original shape no matter how strongly it is deformed. This is an ideal concept only; most materials which possess elasticity in practice remain purely elastic only up to very small deformations, after which plastic (permanent) deformation occurs.

In engineering, the elasticity of a material is quantified by the elastic modulus such as the Young's modulus, bulk modulus or shear modulus which measure the amount of stress needed to achieve a unit of strain; a higher modulus indicates that the material is harder to deform. The material's elastic limit or yield strength is the maximum stress that can arise before the onset of plastic deformation.

Plasticity (physics):

Deformation of a solid material undergoing non-reversible changes of shape in response to applied forces.

In physics and materials science, plasticity, also known as plastic deformation, is the

ability of a solid material to undergo permanent deformation, a non-reversible change of shape in response to applied forces. For example, a solid piece of metal being bent or pounded into a new shape displays plasticity as permanent changes occur within the material itself. In engineering, the transition from elastic behavior to plastic behavior is known as yielding.

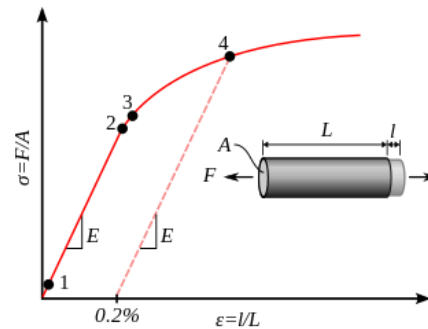

Stress–strain curve showing typical yield behavior for nonferrous alloys.

1. True elastic limit
2. Proportionality limit
3. Elastic limit
4. Offset yield strength

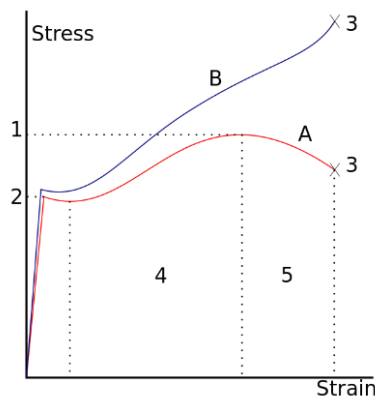

A stress–strain curve typical of structural steel.

- 1: Ultimate strength
- 2: Yield strength (yield point)
- 3: Rupture
- 4: Strain hardening region
- 5: Necking region
- A: Apparent stress (F/A_0)
- B: Actual stress (F/A)

Plastic deformation is observed in most materials, particularly metals, soils, rocks, concrete, and foams. However, the physical

mechanisms that cause plastic deformation can vary widely. At a crystalline scale, plasticity in metals is usually a consequence of dislocations. Such defects are relatively rare in most crystalline materials, but are numerous in some and part of their crystal structure; in such cases, plastic crystallinity can result. In brittle materials such as rock, concrete and bone, plasticity is caused predominantly by slip at microcracks. In cellular materials such as liquid foams or biological tissues, plasticity is mainly a consequence of bubble or cell rearrangements, notably T1 processes.

For many ductile metals, tensile loading applied to a sample will cause it to behave in an elastic manner. Each increment of load is accompanied by a proportional increment in extension. When the load is removed, the piece returns to its original size. However, once the load exceeds a threshold – the yield strength – the extension increases more rapidly than in the elastic region; now when the load is removed, some degree of extension will remain.

Elastic deformation, however, is an approximation and its quality depends on the time frame considered and loading speed. If, as indicated in the graph opposite, the deformation includes elastic deformation, it is also often referred to as "elasto-plastic deformation" or "elastic-plastic deformation".

Perfect plasticity is a property of materials to undergo irreversible deformation without any increase in stresses or loads. Plastic materials that have been hardened by prior deformation, such as cold forming, may need increasingly higher stresses to deform further. Generally, plastic deformation is also dependent on the deformation speed, i.e. higher stresses usually have to be applied to increase the rate of deformation. Such materials are said to deform viscoplastically.”

Viscoelasticity:

Property of materials with both viscous and elastic characteristics under deformation.

In materials science and continuum mechanics, viscoelasticity is the property of materials that exhibit both viscous and elastic characteristics when undergoing deformation. Viscous materials, like water,

resist shear flow and strain linearly with time when a stress is applied. Elastic materials strain when stretched and immediately return to their original state once the stress is removed.

Viscoelastic materials have elements of both of these properties and, as such, exhibit time-dependent strain. Whereas elasticity is usually the result of bond stretching along crystallographic planes in an ordered solid, viscosity is the result of the diffusion of atoms or molecules inside an amorphous material.

In the nineteenth century, physicists such as Maxwell, Boltzmann, and Kelvin researched and experimented with creep and recovery of glasses, metals, and rubbers. Viscoelasticity was further examined in the late twentieth century when synthetic polymers were engineered and used in a variety of applications. Viscoelasticity calculations depend heavily on the viscosity variable, η . The inverse of η is also known as fluidity, ϕ . The value of either can be derived as a function of temperature or as a given value (i.e., for a dashpot).

Depending on the change of strain rate versus stress inside a material, the viscosity can be categorized as having a linear, non-linear, or plastic response. When a material exhibits a linear response, it is categorized as a Newtonian material. In this case the stress is linearly proportional to the strain rate. If the material exhibits a non-linear response to the strain rate, it is categorized as non-Newtonian fluid. There is also an interesting case where the viscosity decreases as the shear/strain rate remains constant. A material which exhibits this type of behavior is known as thixotropic. In addition, when the stress is independent of this strain rate, the material exhibits plastic deformation. Many viscoelastic materials exhibit rubber like behavior explained by the thermodynamic theory of polymer elasticity.

Cracking occurs when the strain is applied quickly and outside of the elastic limit. Ligaments and tendons are viscoelastic, so the extent of the potential damage to them depends both on the rate of the change of their length as well as on the force applied.

A viscoelastic material has the following properties:

- hysteresis is seen in the stress–strain curve
- stress relaxation occurs: step constant strain causes decreasing stress
- creep occurs: step constant stress causes increasing strain
- its stiffness depends on the strain rate or the stress rate.

Elastic versus viscoelastic behavior

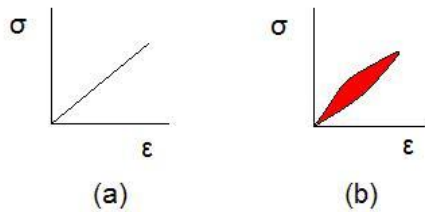

Stress–strain curves for a purely elastic material (a) and a viscoelastic material (b). The red area is a hysteresis loop and shows the amount of energy lost (as heat) in a loading and unloading cycle. It is equal to

$$\oint \sigma d\epsilon$$

where σ is stress and ϵ is strain.

Unlike purely elastic substances, a viscoelastic substance has an elastic component and a viscous component. The viscosity of a viscoelastic substance gives the substance a strain rate dependence on time. Purely elastic materials do not dissipate energy (heat) when a load is applied, then removed. However, a viscoelastic substance dissipates energy when a load is applied, then removed. Hysteresis is observed in the stress–strain curve, with the area of the loop being equal to the energy lost during the loading cycle. Since viscosity is the resistance to thermally activated plastic deformation, a viscous material will lose energy through a loading cycle. Plastic deformation results in lost energy, which is uncharacteristic of a purely elastic material's reaction to a loading cycle.

Specifically, viscoelasticity is a molecular rearrangement. When a stress is applied to a viscoelastic material such as a polymer, parts of the long polymer chain change positions. This movement or rearrangement is called “creep”. Polymers remain a solid material even when these parts of their chains are rearranging in order to accompany the stress,

and as this occurs, it creates a back stress in the material. When the back stress is the same magnitude as the applied stress, the material no longer creeps. When the original stress is taken away, the accumulated back stresses will cause the polymer to return to its original form. The material creeps, which gives the prefix visco-, and the material fully recovers, which gives the suffix -elasticity.

Viscoplasticity:

Viscoplasticity is a theory in continuum mechanics that describes the rate-dependent inelastic behavior of solids. Rate-dependence in this context means that the deformation of the material depends on the rate at which loads are applied. The inelastic behavior that is the subject of viscoplasticity is plastic deformation which means that the material undergoes unrecoverable deformations when a load level is reached. Rate-dependent plasticity is important for transient plasticity calculations. The main difference between rate-independent plastic and viscoplastic material models is that the latter exhibit not only permanent deformations after the application of loads but continue to undergo a creep flow as a function of time under the influence of the applied load.

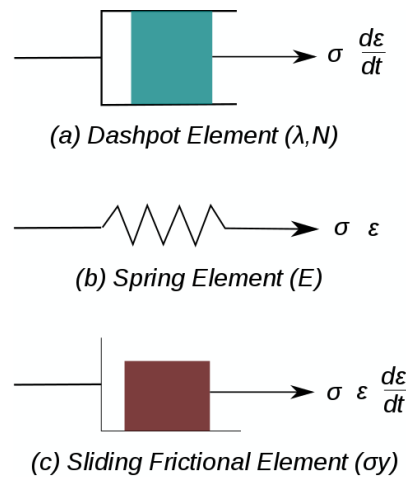

Figure 1. Elements used in one-dimensional models of viscoplastic materials.

The elastic response of viscoplastic materials can be represented in one-dimension by Hookean spring elements. Rate-dependence can be represented by nonlinear dashpot elements in a manner similar to viscoelasticity. Plasticity can be accounted for by adding sliding frictional elements as shown in Figure 1. In the figure E is the

modulus of elasticity, λ is the viscosity parameter and N is a power-law type parameter that represents non-linear dashpot [$\sigma(d\varepsilon/dt) = \sigma = \lambda(d\varepsilon/dt)^{1/N}$]. The sliding element can have a yield stress (σ_y) that is strain rate dependent, or even constant, as shown in Figure 1c.

Viscoplasticity is usually modeled in three-dimensions using overstress models of the Perzyna or Duvaut-Lions types. In these models, the stress is allowed to increase beyond the rate-independent yield surface upon application of a load and then allowed to relax back to the yield surface over time. The yield surface is usually assumed not to be rate-dependent in such models. An alternative approach is to add a strain rate dependence to the yield stress and use the techniques of rate independent plasticity to calculate the response of a material.

For metals and alloys, viscoplasticity is the macroscopic behavior caused by a mechanism linked to the movement of dislocations in grains, with superposed effects of inter-crystalline gliding. The mechanism usually becomes dominant at temperatures greater than approximately one third of the absolute melting temperature. However, certain alloys exhibit viscoplasticity at room temperature (300K). For polymers, wood, and bitumen, the theory of viscoplasticity is required to describe behavior beyond the limit of elasticity or viscoelasticity.

In general, viscoplasticity theories are useful in areas such as

- the calculation of permanent deformations,
- the prediction of the plastic collapse of structures,
- the investigation of stability,
- crash simulations,
- systems exposed to high temperatures such as turbines in engines, e.g. a power plant,
- dynamic problems and systems exposed to high strain rates.

Phenomenology

For a qualitative analysis, several characteristic tests are performed to describe the phenomenology of viscoplastic materials. Some examples of these tests are

1. hardening tests at constant stress or strain rate,
2. creep tests at constant force, and
3. stress relaxation at constant elongation.

Strain hardening test

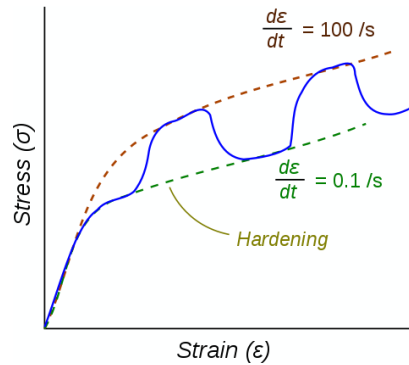

Figure 2. Stress–strain response of a viscoplastic material at different strain rates.

The dotted lines show the response if the strain-rate is held constant. The blue line shows the response when the strain rate is changed suddenly.

One consequence of yielding is that as plastic deformation proceeds, an increase in stress is required to produce additional strain. This phenomenon is known as Strain/Work hardening. For a viscoplastic material the hardening curves are not significantly different from those of rate-independent plastic material. Nevertheless, three essential differences can be observed.

1. At the same strain, the higher the rate of strain the higher the stress.
2. A change in the rate of strain during the test results in an immediate change in the stress–strain curve.
3. The concept of a plastic yield limit is no longer strictly applicable.

The hypothesis of partitioning the strains by decoupling the elastic and plastic parts is still applicable where the strains are small, i.e.,

$$\varepsilon = \varepsilon_e + \varepsilon_{vp}$$

where ε_e is the elastic strain and ε_{vp} is the viscoplastic strain.

To obtain the stress–strain behavior shown in blue in the figure, the material is initially

loaded at a strain rate of 0.1/s. The strain rate is then instantaneously raised to 100/s and held constant at that value for some time. At the end of that time period the strain rate is dropped instantaneously back to 0.1/s and the cycle is continued for increasing values of strain. There is clearly a lag between the strain-rate change and the stress response. This lag is modeled quite accurately by overstress models (such as the Perzyna model) but not by models of rate-independent plasticity that have a rate-dependent yield stress.”

2.2 Hysteresis and avalanches

(From Professor James Sethna, Physical Science Department of Cornell University)

Physicists in the US usually hear about hysteresis first in their sophomore or junior year. You likely won’t hear about hysteresis again in your courses. It was an unpopular subject for decades.

Experimentalists generally tried to get rid of it, so they could get publishable equilibrium, data. Theorists cringed from thinking about non-equilibrium, dirty materials with long-range elastic or magnetic forces. But styles change: dirt and non-equilibrium are now a major focus of research in physics.

What’s gotten us excited is the noise found in hysteresis loops. Even though they look smooth, hysteresis loops often consist of many small jumps. These jumps can be thought of as the jerk motion of a domain boundary, or as an avalanche of many local spins or domains.

Note: For a more detailed description, please refer to the “consolidated method” section which is given at the beginning of the special issue.

3. RESULTS

Figure 1 displays three stress-strain diagrams in SD for three periods.

Figure 2 shows eAG waveforms in TD and their associated frequency curves in the frequency domain along with the summary of energy results.

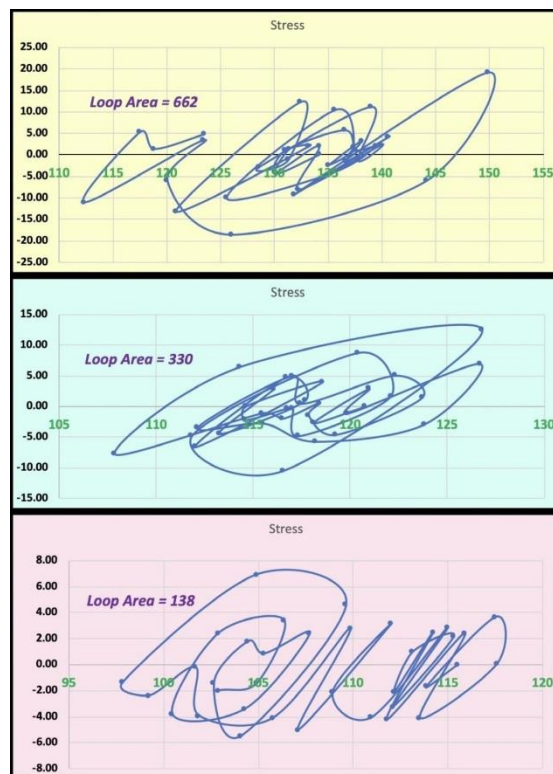

Figure 1: Three stress-strain diagrams in space domain for three periods.

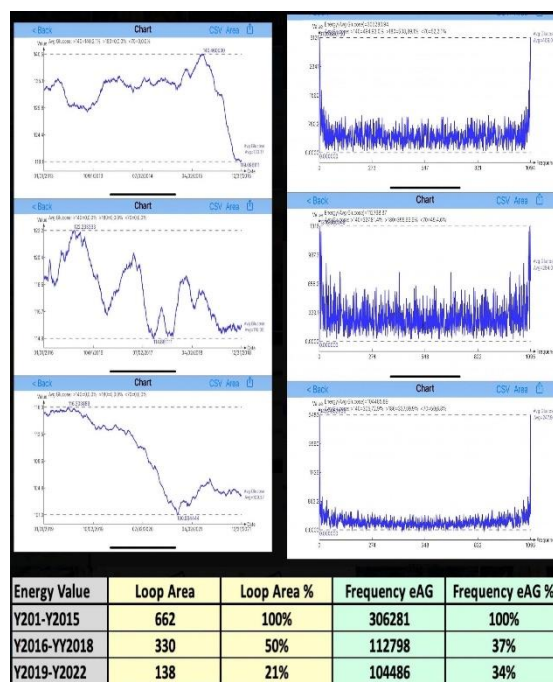

Figure 2: eAG waveforms in the time domain and their associated frequency curves in the frequency domain along with the summary of energy results.

4. CONCLUSION

In conclusion, the following five described biophysical observations have demonstrated the main characteristics and behaviors of both viscoelasticity and viscoplasticity, VGT

energy, and frequency energy estimation via fast Fourier transformation:

(1) When body weight drops continuously over the 3 triple-year periods, his eAG also decreases accordingly. This eAG reduction can be seen clearly from the three scales of strain, i.e. x-axis scales. See the data of (BW, eAG): Y13-15 = (178 lbs., 132 mg/dL); Y16-18 = (173 lbs., 118 mg/dL); Y19-21 = (170 lbs., 108 mg/dL).

(2) From the 3 eAG waveforms in TD, the 180-days moving average curve shapes are different from one another which indicates that the 3 strain rates or eAG change rates of the 3 triple-year periods vary as well.

(3) The three-body weights over the 3 triple-year periods are continuously dropping when time moves forward. This phenomenon provides a clue that the viscosity factor, i.e. η or body weight, is decreasing as time moves forward. Therefore, the stress magnitude is declining from the earlier period to the recent period since stress is the strain rate multiplied by the viscosity factor of body weight. Please note that the body weights used as the viscosity factors are divided by 170 lbs. (BMI of 25.0). See the continuously decreasing stress range or x-axis scale: Y13-15 = (-25 to 25); Y16-18 = (-15 to 15); Y16-18 = (-8 to 8).

(4) The calculated hysteresis loop area is continuously reducing from earlier period to recent period since the loop area is the summation of all trapezoid sub-areas of the stress-strain curve for each triple-year period. From a mathematical viewpoint, this makes perfect sense when the strain and stress are on a downward sliding scale, their loop areas follow the same path. The three-loop areas represent the associated relative energy of eAG under the influence of body weight within each period. See the relative energy associated with three different hysteresis loop areas: Y13-15 = 662; Y16-18 = 330; Y16-18 = 138.

(5) Using the Fourier Transform technique to convert the eAG wave from a time domain into a frequency domain, the total area underneath the frequency curve of each period also indicates the associated relative energy of the corresponding eAG in each period. See the frequency energy areas: Y13-15 = 306,281; Y16-18 = 112,798; Y16-18 = 104,486.

In summary, body weight influences glucose. The energy in glucose circulates with the blood flow inside the body. If we have excessive energy within the blood flow, it can damage internal organs and cause various types of complications. From this study, the 9-year biomarker data are further grouped into three identical triple-year sub-periods. Here is the energy ratio for every 3 periods as follows:

(1) Energy ratio using VGT method: 100%, 50%, and 21%

(2) Energy ratio using Frequency method: 100%, 37%, and 34%

These two energy ratios have similar patterns of continuous reduction when his body weight and glucose conditions improve.

5. REFERENCES

For editing purposes, the majority of the references in this paper, which are self-references, have been removed. Only references from other authors' published sources remain. The bibliography of the author's original self-references can be viewed at www.eclaircmd.com.

Readers may use this article as long as the work is properly cited, their use is educational and not for profit, and the author's original work is not altered.

Viscoelastic and Viscoplastic Glucose Theory Application in Medicine

Gerald C. Hsu

