

# The GH-Method

---

## **Viscoelastic or Viscoplastic Glucose Theory (VGT #62): A Simplified Mathematical Model to Estimate Liver Cancer Risk Probability Percentages and its Moving Trend Over 12+ Years from 1/1/2010 to 4/14/2022 Using Type 2 Diabetes HbA1C, Obesity, Blood Lipids, and Metabolism Index as the Liver Cancer Risk's 4 Influential Factors Based on GH-Method: Math-Physical Medicine (No. 650)**

Gerald C. Hsu\*

eclairMD Foundation, USA

**Note:** Readers who want to get a quick overview can read the abstract, results, and graphs.

### **Abstract**

Recently, the author read a few published medical articles regarding liver cancer and outlines some key information in the Introduction section. The selected information sources have been referenced within this section of the article and will not list again in the Reference section.

“Liver Cancer:

<https://www.cdc.gov/dpcp/research>

An Update on Cancer Deaths in the United States | CDC

Feb 28, 2022

What were the leading causes of cancer death in 2020? Lung cancer was the leading cause of cancer death, accounting for 23% of all cancer deaths. Other common causes of cancer death were cancers of the colon and rectum (9%), pancreas (8%), female breast (7%), prostate (5%), and liver and intrahepatic bile duct (5%).

<https://www.webmd.com/news>

Type 2 Diabetes Might Raise Risk of Liver Cancer – WebMD

Dec 8, 2013

Can diabetes cause liver cancer?

The research suggests that those with type 2 diabetes have about two to three times greater risk of developing hepatocellular carcinoma (HCC) -- the most common type of liver cancer -- compared to those without diabetes. Still, the risk of developing liver cancer remains low, experts said. <https://www.riversideonline.com> > d...

Can diabetes cause liver cancer? - Riverside Health System

Jan 27, 2022

Can diabetes cause liver cancer?

Worldwide, liver cancer is the fifth most common cancer in men, while it is the seventh most commonly diagnosed cancer in women. Type 2

diabetes is a significant risk factor for this lethal type of cancer. There's not enough research to say that type 2 diabetes directly causes liver cancer, but scientists have identified a strong connection. While type 2 diabetes and related chronic health conditions like being overweight or obese are common, they are also preventable and manageable. With some healthy lifestyle changes and support, you can protect your liver and reduce your risk for cancer.

The diabetes liver connection

Like the first domino in a chain reaction, the lack of blood sugar regulation in type 2 diabetes can wreak havoc on the body, and the liver is no exception.

Obesity, type 2 diabetes, and dyslipidemia (an imbalance of lipids or fats in the blood) are the most common metabolic risk factors associated with non-alcoholic fatty liver disease (NAFLD), where too much fat accumulates in the liver. In type 2 diabetes, the liver cannot keep up with the demands of constantly managing high blood sugar, so excess fat is created. Having NAFLD places you at a higher risk of developing liver cancer.

Without lifestyle change, NAFLD can irreparably inflame and scar the liver, causing what is known as cirrhosis. Most people with liver cancer have cirrhosis, a well-known risk factor for the disease. Liver cancer risk with diabetes

Type 2 diabetes starts a progression of challenging health problems that damage the liver, increasing the likelihood of liver cancer. “Individuals with type 2 diabetes are two to four times more likely to develop liver cancer compared with non-diabetics,” says Michael Ney, M.D., a board-certified, fellowship-trained gastroenterologist with Riverside Gastroenterology Specialists. Researchers have not teased out all the factors

that connect type 2 diabetes to liver cancer. However, insulin resistance, liver damage, and even diabetes medications may play a role.

Protect the liver —and prevent liver cancer — with lifestyle change

Not all risk factors for liver cancer are controllable, but preventing and managing your diabetes is one thing you can do to reduce your risk.

Take the following steps to keep your blood sugar in a healthy range:

- Work toward achieving a healthy body weight
- Eat a low glycemic diet filled with vegetables, fruits, beans, and whole grains
- Avoid added sugars, particularly in beverages
- Drink alcohol in moderation or not at all
- Stay physically active

In addition to lifestyle changes, you should work with your doctor to manage your blood sugar. They may recommend routine labs like fasting blood sugar or hemoglobin A1C. You may also need additional support with medications that lower blood sugar.

People with type 2 diabetes often develop a condition called "fatty liver," D'Olimpio said. In these cases, the liver has trouble handling the abundance of fat in its cells and gradually becomes inflamed. That situation can trigger a cascade of problems, including cirrhosis (a chronic disease of the liver), fibrosis (thickening and scarring of tissue), and, ultimately, cancer, he said.

D'Olimpio said fatty liver disease is the No. 1 cause of Hepatocellular carcinoma (HCC). "Type 2 diabetics have twice the chance of having a fatty liver, at least," he said. "If you're an African-American or Latino, that may make you even more susceptible."

People with type 1 diabetes, however, do not have an increased risk of liver cancer, he said.

Information about risk factors -- such as age, whether they had type 2 diabetes, alcohol intake, body-mass index (a measure of body fat), and cigarette smoking -- was analyzed, and blood tests for hepatitis B and hepatitis C were performed on about 700 of the participants, with and without liver cancer.

Whether people smoked or drank alcohol did not appear to change the relationship between having diabetes and getting liver cancer, the researchers said.

Although the study found an association between having type 2 diabetes and developing liver cancer, it did not prove a cause-and-effect relationship.

North Shore's Bernstein urged caution in interpreting the results. "It's a single study that talks about a large number of people with a common disease like diabetes and links it to liver cancer," he said. "We have a lot more learning to do and more work is needed to prove an association and define what the risk is."

A study this month by the American Diabetes Association showed that many Americans are unaware that they are at risk for type 2 diabetes. D'Olimpio urged people to get a simple blood test,

called fasting blood sugar, to test for diabetes.

The next step is to learn what role genetics may play in whether an individual with type 2 diabetes will develop liver cancer, study author Setiawan said.

The Ohio State Comprehensive Cancer Center – Arthur G. James Cancer Hospital and Richard J. Solove Research Institute (OSUCCC – James). JULY 30, 2012

Contact: Darrell E. Ward, Medical Center Public Affairs and Media Relations, 614-293-3737, or Darrell.Ward@osumc.edu

Liver Cancer Cells Stop Making Glucose As They Become Cancerous

- Liver cells normally produce glucose to help maintain healthy blood sugar levels, but they lose that ability when they become cancerous, this study shows.
- This change might benefit tumor cells by helping them grow and proliferate.
- The study tracks how this loss happens and suggests that reversing it might offer a new way to treat this often-deadly disease.

COLUMBUS, Ohio – As liver cancer develops, tumor cells lose the ability to produce and release glucose into the bloodstream, a key function of healthy liver cells for maintaining needed blood-sugar levels.

The loss of this type of glucose production, a process called gluconeogenesis, is caused by the over-expression of a molecule called microRNA-23a. The change might aid cancer-cell growth and proliferation by helping to maintain high levels of glycolysis under conditions of drastically reduced mitochondrial respiration, also known as the Warburg effect.

The findings suggest that suppressing miR-23a might reverse this process and offer a new treatment for hepatocellular carcinoma (HCC), the most common form of liver cancer.

The following research is published in *Hepatology*. "This study identifies an important mechanism that severely blocks glucose production and its release from the liver as liver cells transform into cancer cells," says principal investigator Dr. Samson Jacob, professor of molecular and cellular biochemistry, and William and Joan Davis Professor in Cancer Research, Division of Hematology and Oncology at Ohio State and co-leader of the OSUCCC – James Experimental Therapeutics Program. "It is conceivable that delivery of an anti-miR23a to the tumor site could reverse this."

For this study, Jacob and his colleagues used an animal model that develops diet-induced HCC, along with primary-tumor samples from patients and HCC cell lines. The mouse model mimics different stages of human hepatocarcinogenesis. Key findings include:

- Levels of enzymes in the gluconeogenesis pathway were drastically reduced, along with transcription factors involved in the expression of the genes encoding those enzymes.
- miR-23a expression was significantly up-regulated in the animal model and primary human HCC.
- miR-

23a suppresses the enzyme glucose-6-phosphatase and the transcription factor PGC-1a, two important components of the gluconeogenesis pathway. • Interleukin-6 and Stat-3 signaling cause the upregulation of miR-23a.

"Based on our data," Jacob says, "We conclude that gluconeogenesis is severely compromised in HCC by IL6-Stat3-mediated activation of miR-23a, which directly targets and suppresses glucose-6-phosphatase and PGC-1a, leading to decreased glucose production in HCC."

Jacob notes that since glucose-6-phosphatase is also essential for liver cells to convert glycogen (the storage form of glucose) to glucose, suppression of this enzyme can block all pathways leading to glucose production by the liver.

#### Review

Is type 2 diabetes mellitus a predisposal cause for developing hepatocellular carcinoma?

Biswajit Mukherjee et al.

Curr Diabetes Rev. 2015

#### Abstract

Hepatic cancer stands as one of the frontier causes of cancer-related mortality worldwide. Among the several risk factors already established, type 2 diabetes is now considered one of the important risks in the progression of liver cancer. Studies have shown that likelihood of occurrence of liver cancer is many folds higher in patients diagnosed with type II diabetes compared to patients without diabetes. The liver plays an important role in the metabolism of glucose in our body, so maybe type II diabetes as it is an important epiphenomenon of hepatic diseases such as liver cirrhosis, liver failure, fatty liver, chronic hepatitis, and hepatocellular carcinoma. Some reports suggested that extensive changes in enzyme structures in the molecular level in diabetic patients may lead to liver function damage and hence accelerate hepatic cancer. Other strong links between these two diseases are "non-alcoholic fatty liver diseases" and "nonalcoholic steatohepatitis" which are metabolic disorders caused by type II diabetes and eventually develop hepatocellular carcinoma. However, it remains unanswered whether the prevention of diabetes would effectively lower the chances of developing liver cancer or whether eliminating diabetes from the population would effectively reduce the liver cancer incidence. In this review, we will primarily focus on the molecular link between type2 diabetes and hepatic cancer and investigate the underlying mechanism to establish type II diabetes as a predisposed cause of hepatic cancer.

#### BRITISH DIABETES COMPLICATIONS

##### Liver Cancer

Written by Editor on January 15, 2019 · Last reviewed January 7, 2022

Liver cancer is a rare type of cancer that affects one of the most complex organs in the human body. Cases of liver cancer in the UK are far and few between but certain people, including those diagnosed with diabetes, face a higher risk of developing cancer than the general population.

As with other forms of cancer, however, many cases of liver cancer can be prevented by keeping healthy lifestyle habits such as eating healthily, keeping fit, and quitting or avoiding smoking. What is liver cancer?

Liver cancer is a general term that refers to either:

- Primary liver cancer – cancer that originates in the liver
- Secondary liver cancer – cancer that spreads to the liver from another part of the body, such as the bowel. Located below the right lung, your liver is the largest internal organ of the human body and one that performs hundreds of important functions, including producing and releasing glucose when the body needs it, converting fats to energy when needed, and removing toxins from the body.

Damage to the liver, which is a common problem for people with diabetes, can disrupt these functions and cause them to fail altogether (liver failure) if left untreated.

How common is liver cancer?

In the UK, nearly 4,000 people are diagnosed with a form of liver cancer each year. The majority of these are secondary liver cancer – primary liver cancer is rare in the UK, but a common problem in other parts of the world. More men are affected than women (60% versus 40%) and cases tend to develop in older adults over the age of 65.

What causes liver cancer?

The exact cause of liver cancer is unclear, but the disease is strongly linked to damage, inflammation, and scarring of the liver, a condition known as cirrhosis. Common causes of cirrhosis include alcohol misuse, viral infections such as hepatitis B or hepatitis C, and non-fatty alcoholic liver disease (NAFLD).

Can diabetes increase my risk?

Type 2 diabetes, the most common form of diabetes mellitus, is considered a risk factor for liver cancer due to its strong association with obesity. Obesity can lead to the build-up of excess fat inside the tissue of your liver (NAFLD), which not only raises the risk of cirrhosis but also heart disease and type 2 diabetes.

But as well as being a type 2 diabetes risk factor, non-alcoholic fatty liver disease is also one of the many health conditions (or complications) that can develop as a result of long-term type 2 diabetes, due largely to the fact that type 2 diabetes tends to develop in people who are overweight or obese. Latest research In December 2013, scientists from the University of Southern California found an association between type 2 diabetes and increased risk of hepatocellular carcinoma or HCC – a rare form of liver cancer linked with having fatty liver disease.

Analysis of more than 150,000 medical records revealed that the likelihood of developing HCC was 2 to 3 times higher in patients diagnosed with type 2 diabetes compared to patients without diabetes.

- Type 2 diabetes is linked with up to 3 times increased liver cancer risk

Screening and diagnosis

For people deemed to be at high risk for developing liver cancer, such as those who have had cirrhosis, regular check-ups are important for identifying any early signs of cancer. Screening tests are usually carried out every six months and involve a blood test followed by an ultrasound examination. If you show any of the signs of liver cancer, your GP may use one of the following tests to confirm a diagnosis of liver cancer:

- CT (computerised tomography) scan
- MRI (magnetic resonance imaging) scan
- Biopsy – a small sample of liver tissue is removed and tested for cancerous cells
- Laparoscopy – a small, flexible camera is slipped into your abdomen and used to examine your liver.

The earlier liver cancer is diagnosed, the higher the chances of it being successfully treated and cured.

Treatment - If diagnosed early, there are a number of ways in which liver cancer can be treated, including:

- Resection – surgery to remove a section of the liver where the cancer is contained
- Liver transplant – replacing the liver with a healthy, donor liver
- Radiofrequency ablation – using heat in the form of an electric charge to destroy the cancerous cells or tumour.

Chemotherapy is also an option for treating late stages of liver cancer where a cure is not usually possible. A combination of powerful cancer-killing medicines is used to delay the progression of cancer and prolong the patient's life. However, in most cases, cancer has advanced too far to be controlled or cured by the time a diagnosis is made. At this stage, the only option doctors have is to relieve pain and any other symptoms of liver cancer the patient may be experiencing.

Learn more

Treating diabetes in patients who also have cancer is often complicated by cancer, cancer therapies such as chemotherapy, and the adverse effects of these treatments. Chemotherapy, for example, can destabilise blood glucose control which will need to be closely monitored by your diabetes care team. In addition, cancer treatment can be delayed by the development of any short-term diabetes complications, such as severe hypoglycemia."

Based on above-quoted information, there are a few important factors that are strongly related to liver cancer (not necessarily in a form of a cause-symptom relationship). In the author's case, they are type 2 diabetes (T2D) conditions expressed by HbA1C values (A1C 6.0 is used as the dividing line), obesity or being overweight expressed by body weight (170 lbs. for BMI 25.0), lipids expressed by m3 value (using an averaged combination of LDL, HDL, TG, and total cholesterol), metabolism index express by MI value (a combined score of 4 medical conditions and 6 lifestyle details with 0.735 as the dividing line). In addition to these 4 important factors, i.e. A1C, weight, m3, and MI, some other components are connected to liver cancer as well, such as alcohol drinking, hepatitis B and C, chronic

inflammation, and certain diabetes medications. However, these factors do not apply to the author since he does not have any lifetime unhealthy habits or those mentioned medical conditions. In fact, he has also ceased taking any diabetes medications as of 12/8/2015. Since he is conducting a study to estimate his liver risk probability percentage over 12+ years from 1/1/2010 to 4/14/2022 by utilizing the collected data of his own body; therefore, it is necessary to provide a brief description of his health history. The author was diagnosed with type two diabetes (T2D) in 1997 with a random glucose check at a 300 mg/dL level; however, his T2D condition most likely began earlier. He suffered his first two chest pain episodes in 1993-1994, along with three more heart episodes until 2007. His primary physician informed him that he had diabetic kidney issues in 2010. He then consulted with two more clinical doctors who advised him to start insulin injections and kidney dialysis immediately. This was his wake-up call. He then decided to save his life by conducting his study and research on food nutrition and chronic diseases that same year. His health profile in 2010 was: body weight at 220 lbs. (BMI 32), average glucose at 280 mg/dL, fasting plasma glucose (FPG) in the early morning at 180 mg/dL, lab-tested HbA1C at 10%, triglycerides at 1160, and his ACR at 116. During the past 13 years, he has made significant lifestyle changes. For example, he consumes less than 20 grams of carbohydrates and sugar per meal, stops eating processed food, reduces his food quantity by 50%, walks 6-7 miles or 10-11 kilometers daily, sleeps 7-8 hours each night, and avoids stress as much as possible. As a matter of fact, he has never drunk alcohol, smoked cigarettes, or used any illicit drugs in his life. As of April 10, 2022, his health profile for the first 3 months of 2022 is a body weight of 169 lbs. BMI 24.95), daily average glucose at 106 mg/dL, FPG in the early morning at 94 mg/dL, lab-tested A1C at 5.8%, triglycerides at 108, and ACR at 16. A significant accomplishment is that he discontinued taking 3 different kinds of diabetes medications since 12/8/2015. Fortunately, he has not detected any sign of cancer to date. Relationships between biomedical causes and biomedical symptoms: As a mathematician/engineer over r0 years and then conducting his medical research work during the past 13 years, the author has discovered that people frequently seek answers, illustrations, or explanations for the relationships between the input variable (force applied on a structure or cause of a disease) and output variable (deformation of a structure or symptom of a disease). However, the multiple relationships between input and output could be expressed with many different matrix formats of  $1 \times 1$ ,  $1 \times n$ ,  $m \times 1$ , or  $m \times n$  ( $m$  or  $n$  means different multiple variables). In addition to these described mathematical complications, the output resulting from one or more inputs can also become an input of another output, which is a symptom of certain

causes that can become a cause of another different symptom. This phenomenon is indeed a complex scenario with “chain effects”. In fact, both engineering and biomedical complications are fundamentally mathematical problems that correlate or conform with many inherent physical laws or principles. Over the past 13 years, in his medical research work, he has encountered more than 100 different sets of biomarkers with almost equal or more amounts of causes (or input variables) and symptoms (or output variables). Since December of 2021, the author applied theories of viscoelasticity and viscoplasticity (VGT) from physics and engineering disciplines to investigate more than 60 sets of input/output biomarkers. The purpose is to identify certain hidden relationships between certain output biomarkers, such as liver cancer risk, and its corresponding multiple inputs, such as HbA1C (including both hyperglycemia and insulin resistance), blood lipids (LDL, HDL, Triglycerides, total cholesterol), obesity or overweight, and metabolism index of 6 lifestyle details and 4 chronic diseases. In this study, the hidden biophysical behaviors and possible inter-relationships among the output symptom and multiple input causes are “time-dependent” and change from time to time. These important time-dependency characteristics provide insight into the liver cancer risk’s moving pattern. It also controls the liver cancer curve shape, the associated energy created, stored, or burned inside during the process of stress up-loading (moving upward or increasing) and stress down-loading (moving downward or decreasing) of the input biomarkers with the output biomarker of liver cancer risk %. This VGT application emphasizes the time-dependency characteristics of involved variables. In the medical field, most biomarkers are time-dependent since body organ cells are organic in nature and change all of the time. Incidentally, VGT can generate a stress-strain curve or cause-symptom curve, known as a “hysteresis loop” in physics, in which area size can also be used to estimate the relative energy created, stored, or burned during the process of uploading (e.g. increasing glucose) and unloading (e.g. decreasing body weight) over the timespan of the Liver cancer risk %. He calls this relative energy the “VGT energy”. It should be emphasized here that both Liver cancer risk % and its associated VGT energy are estimated relative values, not “absolute” values. The following defined stress and strain equations are used to establish the VGT stress-strain diagram in a space domain (SD): VGT strain =  $\varepsilon$  (symptom) = individual symptom at the present time. VGT stress =  $\sigma$  (based on the change rate of strain, symptom, multiplying with one or more viscosity factors or influential factors) =  $\eta * (d\varepsilon/dt) = \eta * (d\text{-strain}/d\text{-time}) = (\text{viscosity factor } \eta \text{ using normalized factor at present time}) * (\text{symptom at present time} - \text{symptom at a previous time})$ , where the strain is the Liver cancer risk percentage and

the stress is his Liver cancer risk change rate multiplied by four preferred input biomarkers as the four viscosity factors. In his VGT studies, sometimes, he carefully selects certain normalization factors for individual input biomarkers, respectively. The normalization factors are the dividing lines between a healthy state and an unhealthy state. For example, 170 lbs. for body weight, 6.0 for HbA1C, 120 mg/dL for glucose, 180 mg/dL for hyperglycemia, and 73.5% for both lipids m3 and overall MI. To offer a simple explanation to readers who do not have a physics or engineering background, the author includes a brief excerpt from Wikipedia regarding the description of basic concepts for elasticity and plasticity theories, viscoelasticity, and viscoplasticity theories from the disciplines of engineering and physics in the method section. In summary, the following five described biophysical characteristics have demonstrated certain key behaviors of his liver cancer risk study using the VGT approach: (1) From the display of 4 influential factors in a time-domain (TD), his A1C has decreased from a severe diabetes condition of 10% to around 5.8% in 2022 (pre-diabetes and near-normal condition without any medication intervention after 2016). His body weight has reduced from an obese condition of 220 lbs. (BMI 32) to 169 lbs. in 2022 (BMI 24.95, a normal weight condition). His lipids (m3) condition has dropped from hyperlipidemia of 1.80 in 2010 and 0.85 in 2011 to below 0.735 after 2012, and 0.83 in 2022 (fluctuating borderline lipid conditions). His overall metabolism index (MI) value started at 1.40 in 2010 and has been gradually lowered to below 0.735 after 2015 and now reach 0.53 in 2022. This shows the results of his stringent lifestyle management program are working to improve his chronic conditions control. As mentioned before, he has not had any chronic inflammation, or hepatitis B and C infections, and he does not drink alcohol at all. (2) From the stress-strain hysteresis loops of VGT analysis in a space-domain, the right half of the first 4-year curves (Y2010-Y2013) have larger differences among these 4 influential curves which can also be observed from the corresponding time-domain curves. However, the left half of the following 8+ year curves (Y2014-Y2022) have close proximity among these 4 influential curves that can be seen from the corresponding time-domain curves. However, in general, the visual check of the y-axis scale ranking is in the order of “A1C, Weight, MI, and lipids”. This ranking order is also similar to the stress value and the hysteresis loop area size rankings. (3) The hysteresis loop areas are 405 for A1C, 338 for weight, 287 for MI, and 224 for lipid m3. The data provides an area ratio of 1.0 : 0.83 : 0.71 : 0.55 for A1C : Weight : MI : lipids m3; or 32% : 27% : 23% : 18% if using 100% as the base. It shows that the control effort on his HbA1C (T2D), weight (obesity or overweight), and MI (management of 6 lifestyles and 4 chronic diseases) has been successful, but he needs to put more effort into his lipids management to get a

better result. (4) His liver cancers risk (strain) equation is:  $0.3 * \text{normalized A1C (A1C / 6.0)} + 0.15 * \text{normalized body weight (weight / 170)} + 0.15 * \text{normalized lipids} + 0.4 * \text{normalized MI}$ ". His calculated liver cancer risk % was at a relative level of 76% in Y2010 and continuously dropped to 40% in Y2022 (only 3+ months of data available). It should be emphasized that all of the risk percentages are relative numbers, not absolute numbers. This observation proves that his Liver cancer risk % is being reduced by almost half (~50%) from a relatively higher level of 76% in 2010 down to a relatively lower level of 40% in 2022 through his stringent lifestyle management program. (5) In order to understand his liver

cancer risk deeper, he conducted a sensitivity analysis by using another defined equation for his liver cancer risk %:  $0.25 * \text{normalized A1C (A1C / 6.0)} + 0.25 * \text{normalized body weight (weight / 170)} + 0.25 * \text{normalized lipids} + 0.25 * \text{normalized MI}$ ". The ending results from this evenly distributed weighting factors case are very close to the results from the original unevenly distributed weighting factors. This article has demonstrated how the author utilizes the physics and engineering, VGT methodology, to construct and display his research result findings of liver cancer risk % via time-domain waves and space-domain stress-strain curves.

**Keywords:** Viscoelastic; Viscoplastic; Liver cancer; Type 2 diabetes HbA1C; Obesity, Blood lipids; Metabolism index; Fasting plasma glucose; Postprandial plasma glucose

**Abbreviations:** T2D: type 2 diabetes; SD: space domain; TD: time domain; MI: metabolism index; PPG: postprandial plasma glucose; FPG: fasting plasma glucose; MPM: math-physical medicine

## 1. INTRODUCTION

Recently, the author read a few published medical articles regarding liver cancer and outlines some key information in the Introduction section. The selected information sources have been referenced within this section of the article and will not list again in the Reference section.

Based on above-quoted information, there are a few important factors that are strongly related to liver cancer (not necessarily in a form of a cause-symptom relationship). In the author's case, they are type 2 diabetes (T2D) conditions expressed by HbA1C values (A1C 6.0 is used as the dividing line), obesity or being overweight expressed by body weight (170 lbs. for BMI 25.0), lipids expressed by m3 value (using an averaged combination of LDL, HDL, TG, and total cholesterol), metabolism index expressed by MI value (a combined score of 4 medical conditions and 6 lifestyle details with 0.735 as the dividing line). In addition to these 4 important factors, i.e. A1C, weight, m3, and MI, some other components are connected to liver cancer as well, such as alcohol drinking, hepatitis B and C, chronic inflammation, and certain diabetes medications. However, these factors do not apply to the author since he does not have any lifetime unhealthy habits or those mentioned medical conditions. In fact, he has also ceased taking any diabetes medications as of 12/8/2015.

Since he is conducting a study to estimate his liver risk probability percentage over 12+ years from 1/1/2010 to 4/14/2022 by utilizing the collected data of his own body; therefore, it is necessary to provide a brief description of his health history.

The author was diagnosed with type two diabetes (T2D) in 1997 with a random glucose check at a 300 mg/dL level; however, his T2D condition most likely began earlier. He suffered his first two chest pain episodes in 1993-1994, along with three more heart episodes until 2007. His primary physician informed him that he had diabetic kidney issues in 2010. He then consulted with two more clinical doctors who advised him to start insulin injections and kidney dialysis immediately. This was his wake-up call. He then decided to save his life by conducting his

study and research on food nutrition and chronic diseases that same year. His health profile in 2010 was: body weight at 220 lbs. (BMI 32), average glucose at 280 mg/dL, fasting plasma glucose (FPG) in the early morning at 180 mg/dL, lab-tested HbA1C at 10%, triglycerides at 1160, and his ACR at 116.

During the past 13 years, he has made significant lifestyle changes. For example, he consumes less than 20 grams of carbohydrates and sugar per meal, stops eating processed food, reduces his food quantity by 50%, walks 6-7 miles or 10-11 kilometers daily, sleeps 7-8 hours each night, and avoids stress as much as possible. As a matter of fact, he has never drunk alcohol, smoked cigarettes, or used any illicit drugs in his life.

As of April 10, 2022, his health profile for the first 3 months of 2022 is a body weight of 169 lbs. BMI 24.95), daily average glucose at 106 mg/dL, FPG in the early morning at 94 mg/dL, lab-tested A1C at 5.8%, triglycerides at 108, and ACR at 16. A significant accomplishment is that he discontinued taking 3 different kinds of diabetes medications since 12/8/2015. Fortunately, he has not detected any sign of cancer to date.

Relationships between biomedical causes and biomedical symptoms:

As a mathematician/engineer over 40 years and then conducting his medical research work during the past 13 years, the author has discovered that people frequently seek answers, illustrations, or explanations for the relationships between the input variable (force applied on a structure or cause of a disease) and output variable (deformation of a structure or symptom of a disease). However, the multiple relationships between input and output could be expressed with many different matrix formats of  $1 \times 1$ ,  $1 \times n$ ,  $m \times 1$ , or  $m \times n$  ( $m$  or  $n$  means different multiple variables). In addition to these described mathematical complications, the output resulting from one or more inputs can also become an input of another output, which is a symptom of certain causes that can become a cause of another different symptom. This phenomenon is indeed a complex scenario with "chain effects". In fact, both engineering and biomedical complications

are fundamentally mathematical problems that correlate or conform with many inherent physical laws or principles. Over the past 13 years, in his medical research work, he has encountered more than 100 different sets of biomarkers with almost equal or more amounts of causes (or input variables) and symptoms (or output variables).

Since December of 2021, the author applied theories of viscoelasticity and viscoplasticity (VGT) from physics and engineering disciplines to investigate more than 60 sets of input/output biomarkers. The purpose is to identify certain hidden relationships between certain output biomarkers, such as liver cancer risk, and its corresponding multiple inputs, such as HbA1C (including both hyperglycemia and insulin resistance), blood lipids (LDL, HDL, Triglycerides, total cholesterol), obesity or overweight, and metabolism index of 6 lifestyle details and 4 chronic diseases. In this study, the hidden biophysical behaviors and possible inter-relationships among the output symptom and multiple input causes are “time-dependent” and change from time to time. These important time-dependency characteristics provide insight into the liver risk’s moving pattern. It also controls the liver cancer curve shape, the associated energy created, stored, or burned inside during the process of stress up-loading (moving upward or increasing) and stress down-loading (moving downward or decreasing) of the input biomarkers with the output biomarker of liver cancer risk %. This VGT application emphasizes the time-dependency characteristics of involved variables. In the medical field, most biomarkers are time-dependent since body organ cells are organic in nature and change all of the time. Incidentally, VGT can generate a stress-strain curve or cause-symptom curve, known as a “hysteresis loop” in physics, in which area size can also be used to estimate the relative energy created, stored, or burned during the process of uploading (e.b. increasing glucose) and unloading (e.g. decreasing body weight) over the timespan of the Liver cancer risk %. He calls this relative energy the “VGT energy”.

It should be emphasized here that both Liver cancer risk % and its associated VGT energy are estimated relative values, not “absolute” values.

The following defined stress and strain equations are used to establish the VGT stress-strain diagram in a space domain (SD):

VGT strain  
 $= \varepsilon$  (symptom)  
 $=$  individual symptom at the present time

VGT stress  
 $= \sigma$  (based on the change rate of strain, symptom, multiplying with one or more viscosity factors or influential factors)  
 $= \eta * (d\varepsilon/dt)$   
 $= \eta * (d\text{-strain}/d\text{-time})$   
 $=$  (viscosity factor  $\eta$  using normalized factor at present time) \* (symptom at present time - symptom at a previous time)

Where the strain is the Liver cancer risk percentage and the stress is his Liver cancer risk change rate multiplied by four preferred input biomarkers as the four viscosity factors. In his VGT studies, sometimes, he carefully selects certain normalization factors for individual input biomarkers, respectively. The normalization factors are the dividing lines between a healthy state and an unhealthy state. For example, 170 lbs. for body weight, 6.0 for HbA1C, 120 mg/dL for glucose, 180 mg/dL for hyperglycemia, and 73.5% for both lipids m3 and overall MI.

To offer a simple explanation to readers who do not have a physics or engineering background, the author includes a brief excerpt from Wikipedia regarding the description of basic concepts for elasticity and plasticity theories, viscoelasticity, and viscoplasticity theories from the disciplines of engineering and physics in the method section.

## 2. METHODS

### 2.1 Metabolism index (MI) model

This model was developed in Y2014 by the author using the topology concept, nonlinear algebra, geometric algebra, and engineering finite element method. In summary, the human body metabolism is a complex mathematical problem with a matrix format of  $m$  causes by  $n$  symptoms.

During 2010 and 2011, the author collected sparse biomarker data, but from the beginning of 2012, he has been gathering

body weight and finger-piercing glucose values each day. More complete data collection started in Y2015. That is why this PC risk % study's initial year is 2015. In addition, he accumulates medical conditions data including blood pressure (BP), heart rate (HR), and blood lipids along with lifestyle details (LD). Since 2020, he has added the daily body temperature and blood oxygen level due to his concerns about being exposed to COVID-19. Based on the collected big data of biomarkers, he further organized them into two main groups. The first is the medical conditions group (MC) with 4 categories: weight, glucose, BP, and blood lipids. The second is the lifestyle details group (LD) with 6 categories: food & diet, exercise, water intake, sleep, stress, and daily routines. At first, he calculated a unique combined daily score for each of the 10 categories within the MC and LD groups. The combined scores of the 2 groups, 10 categories, and 500+ detailed elements constitute an overall “metabolism index (MI) model”. It includes the root causes of 6 major lifestyle inputs and symptoms from 4 rudimentary chronic diseases: obesity, diabetes, hypertension, and hyperlipidemia. Therefore, the MI model, especially its 4 chronic disease conditions, can be used as the foundation and building block for his additional research work that can expand into various complications associated with different organs, such as this article’s scope of CVD, CKD, DR, and various cancers (Cancer). Of course, the same methodology can be extended to the study of many other complications, such as various heart problems (CVD & CHD), stroke, neuropathy, hypothyroidism, diabetic constipation, diabetic skin fungal infection, cancers, and dementia.

Some genetic conditions and lifetime unhealthy habits, which include smoking, alcohol consumption, and illicit drug use, account for approximately 15% to 25% of the root cause of chronic diseases and their complications, as well as cancers and dementia. His calculated risk probability % for CKD, CVD, DR, stroke, and various cancers have some differences in their individual root-cause variables, their associated weighting factors for each key cause, and certain biomedical assumptions. Specifically, the CVD/Stroke risk includes two major scenarios that combine emphasized weighting factors, blood vessel

blockage due to blood glucose and blood lipids, and blood vessel rupture caused by blood glucose and blood pressure. Some recent research work has identified the relationship between pancreatic cancer with hyperglycemia and insulin resistance phenomena of T2D, and inflammation. There is also evidence of a relationship between BP and DR (Reference: BP control and DR, by R. Klein and BEK Klein from British Journal of Ophthalmology). The CKD risks include hyperglycemic damage to micro-blood vessels and nerves which causes protein leakage found in urine and waste deposit within the kidneys; therefore, it requires dialysis to remove waste products and excess fluids from the body. However, the cancer risk also consists of additional influences from environmental conditions, such as improper medications, viral infections, food pollution or poison, toxic chemical, radiation, air and water pollution, hormonal treatment, etc.

All of the above-mentioned diseases fall into the category of “symptoms” which are the outcomes of “root causes” of poor living environments and unhealthy lifestyles.

## **2.2 Elasticity, plasticity, viscoelasticity, and viscoplasticity**

The difference between elastic materials and viscoelastic materials (from “Soborthans, innovating shock and vibration solutions”).

What are elastic materials?

Elasticity is the tendency of solid materials to return to their original shape after forces are applied on them. When the forces are removed, the object will return to its initial shape and size if the material is elastic.

What are viscous materials?

Viscosity is a measure of a fluid’s resistance to flow. A fluid with large viscosity resists motion. A fluid with low viscosity flows. For example, water flows more easily than syrup because it has a lower viscosity. High viscosity materials might include honey, syrups, or gels – generally things that resist flow. Water is a low viscosity material, as it flows readily. Viscous materials are thick or sticky or adhesive. Since heating reduces viscosity, these materials don’t flow easily. For example, warm syrup flows more easily than cold.

What is viscoelastic?

Viscoelasticity is the property of materials that exhibit both viscous and elastic characteristics when undergoing deformation. Synthetic polymers, wood, and human tissue, as well as metals at high temperature, display significant viscoelastic effects. In some applications, even a small viscoelastic response can be significant.

Elastic behavior versus viscoelastic behavior

The difference between elastic materials and viscoelastic materials is that viscoelastic materials have a viscosity factor and the elastic ones don't. Because viscoelastic materials have the viscosity factor, they have a strain rate dependent on time. Purely elastic materials do not dissipate energy (heat) when a load is applied, then removed; however, a viscoelastic substance does.

The following brief introductions are excerpts from Wikipedia:

“Elasticity (physics):

The physical property when materials or objects return to original shape after deformation.

In physics and materials science, elasticity is the ability of a body to resist a distorting influence and to return to its original size and shape when that influence or force is removed. Solid objects will deform when adequate loads are applied to them; if the material is elastic, the object will return to its initial shape and size after removal. This is in contrast to plasticity, in which the object fails to do so and instead remains in its deformed state.

The physical reasons for elastic behavior can be quite different for different materials. In metals, the atomic lattice changes size and shape when forces are applied (energy is added to the system). When forces are removed, the lattice goes back to the original lower energy state. For rubbers and other polymers, elasticity is caused by the stretching of polymer chains when forces are applied.

Hooke's law states that the force required to deform elastic objects should be directly proportional to the distance of deformation,

regardless of how large that distance becomes. This is known as perfect elasticity, in which a given object will return to its original shape no matter how strongly it is deformed. This is an ideal concept only; most materials which possess elasticity in practice remain purely elastic only up to very small deformations, after which plastic (permanent) deformation occurs.

In engineering, the elasticity of a material is quantified by the elastic modulus such as the Young's modulus, bulk modulus or shear modulus which measure the amount of stress needed to achieve a unit of strain; a higher modulus indicates that the material is harder to deform. The material's elastic limit or yield strength is the maximum stress that can arise before the onset of plastic deformation.

Plasticity (physics):

Deformation of a solid material undergoing non-reversible changes of shape in response to applied forces.

In physics and materials science, plasticity, also known as plastic deformation, is the ability of a solid material to undergo permanent deformation, a non-reversible change of shape in response to applied forces. For example, a solid piece of metal being bent or pounded into a new shape displays plasticity as permanent changes occur within the material itself. In engineering, the transition from elastic behavior to plastic behavior is known as yielding.

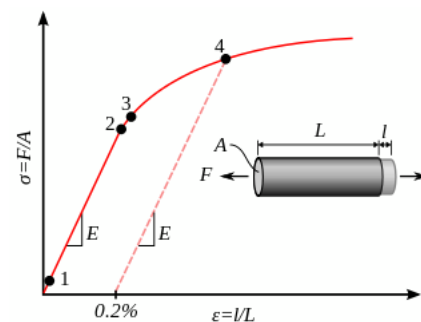

Stress–strain curve showing typical yield behavior for nonferrous alloys.

1. True elastic limit
2. Proportionality limit
3. Elastic limit
4. Offset yield strength

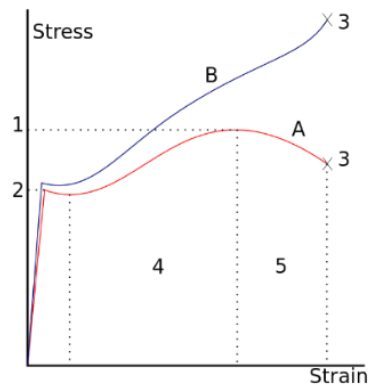

A stress–strain curve typical of structural steel.

- 1: Ultimate strength
- 2: Yield strength (yield point)
- 3: Rupture
- 4: Strain hardening region
- 5: Necking region
- A: Apparent stress ( $F/A_0$ )
- B: Actual stress ( $F/A$ )

Plastic deformation is observed in most materials, particularly metals, soils, rocks, concrete, and foams. However, the physical mechanisms that cause plastic deformation can vary widely. At a crystalline scale, plasticity in metals is usually a consequence of dislocations. Such defects are relatively rare in most crystalline materials, but are numerous in some and part of their crystal structure; in such cases, plastic crystallinity can result. In brittle materials such as rock, concrete and bone, plasticity is caused predominantly by slip at microcracks. In cellular materials such as liquid foams or biological tissues, plasticity is mainly a consequence of bubble or cell rearrangements, notably T1 processes.

For many ductile metals, tensile loading applied to a sample will cause it to behave in an elastic manner. Each increment of load is accompanied by a proportional increment in extension. When the load is removed, the piece returns to its original size. However, once the load exceeds a threshold – the yield strength – the extension increases more rapidly than in the elastic region; now when the load is removed, some degree of extension will remain.

Elastic deformation, however, is an approximation and its quality depends on the time frame considered and loading speed. If,

as indicated in the graph opposite, the deformation includes elastic deformation, it is also often referred to as "elasto-plastic deformation" or "elastic-plastic deformation".

Perfect plasticity is a property of materials to undergo irreversible deformation without any increase in stresses or loads. Plastic materials that have been hardened by prior deformation, such as cold forming, may need increasingly higher stresses to deform further. Generally, plastic deformation is also dependent on the deformation speed, i.e. higher stresses usually have to be applied to increase the rate of deformation. Such materials are said to deform viscoplastically.”

Viscoelasticity:

Property of materials with both viscous and elastic characteristics under deformation. In materials science and continuum mechanics, viscoelasticity is the property of materials that exhibit both viscous and elastic characteristics when undergoing deformation. Viscous materials, like water, resist shear flow and strain linearly with time when a stress is applied. Elastic materials strain when stretched and immediately return to their original state once the stress is removed.

Viscoelastic materials have elements of both of these properties and, as such, exhibit time-dependent strain. Whereas elasticity is usually the result of bond stretching along crystallographic planes in an ordered solid, viscosity is the result of the diffusion of atoms or molecules inside an amorphous material.

In the nineteenth century, physicists such as Maxwell, Boltzmann, and Kelvin researched and experimented with creep and recovery of glasses, metals, and rubbers. Viscoelasticity was further examined in the late twentieth century when synthetic polymers were engineered and used in a variety of applications. Viscoelasticity calculations depend heavily on the viscosity variable,  $\eta$ . The inverse of  $\eta$  is also known as fluidity,  $\phi$ . The value of either can be derived as a function of temperature or as a given value (i.e., for a dashpot).

Depending on the change of strain rate versus stress inside a material, the viscosity can be categorized as having a linear, non-

linear, or plastic response. When a material exhibits a linear response, it is categorized as a Newtonian material. In this case the stress is linearly proportional to the strain rate. If the material exhibits a non-linear response to the strain rate, it is categorized as non-Newtonian fluid. There is also an interesting case where the viscosity decreases as the shear/strain rate remains constant. A material which exhibits this type of behavior is known as thixotropic. In addition, when the stress is independent of this strain rate, the material exhibits plastic deformation. Many viscoelastic materials exhibit rubber like behavior explained by the thermodynamic theory of polymer elasticity.

Cracking occurs when the strain is applied quickly and outside of the elastic limit. Ligaments and tendons are viscoelastic, so the extent of the potential damage to them depends both on the rate of the change of their length as well as on the force applied.

A viscoelastic material has the following properties:

- hysteresis is seen in the stress–strain curve
- stress relaxation occurs: step constant strain causes decreasing stress
- creep occurs: step constant stress causes increasing strain
- its stiffness depends on the strain rate or the stress rate.

Elastic versus viscoelastic behavior

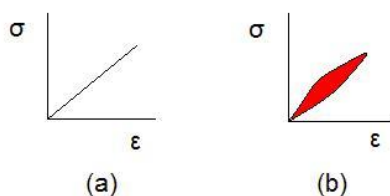

Stress–strain curves for a purely elastic material (a) and a viscoelastic material (b). The red area is a hysteresis loop and shows the amount of energy lost (as heat) in a loading and unloading cycle. It is equal to

$$\oint \sigma d\epsilon$$

where  $\sigma$  is stress and  $\epsilon$  is strain.

Unlike purely elastic substances, a viscoelastic substance has an elastic

component and a viscous component. The viscosity of a viscoelastic substance gives the substance a strain rate dependence on time. Purely elastic materials do not dissipate energy (heat) when a load is applied, then removed. However, a viscoelastic substance dissipates energy when a load is applied, then removed. Hysteresis is observed in the stress–strain curve, with the area of the loop being equal to the energy lost during the loading cycle. Since viscosity is the resistance to thermally activated plastic deformation, a viscous material will lose energy through a loading cycle. Plastic deformation results in lost energy, which is uncharacteristic of a purely elastic material's reaction to a loading cycle.

Specifically, viscoelasticity is a molecular rearrangement. When a stress is applied to a viscoelastic material such as a polymer, parts of the long polymer chain change positions. This movement or rearrangement is called “creep”. Polymers remain a solid material even when these parts of their chains are rearranging in order to accompany the stress, and as this occurs, it creates a back stress in the material. When the back stress is the same magnitude as the applied stress, the material no longer creeps. When the original stress is taken away, the accumulated back stresses will cause the polymer to return to its original form. The material creeps, which gives the prefix visco-, and the material fully recovers, which gives the suffix -elasticity.

Viscoplasticity:

Viscoplasticity is a theory in continuum mechanics that describes the rate-dependent inelastic behavior of solids. Rate-dependence in this context means that the deformation of the material depends on the rate at which loads are applied. The inelastic behavior that is the subject of viscoplasticity is plastic deformation which means that the material undergoes unrecoverable deformations when a load level is reached. Rate-dependent plasticity is important for transient plasticity calculations. The main difference between rate-independent plastic and viscoplastic material models is that the latter exhibit not only permanent deformations after the application of loads but continue to undergo a creep flow as a function of time under the influence of the applied load.

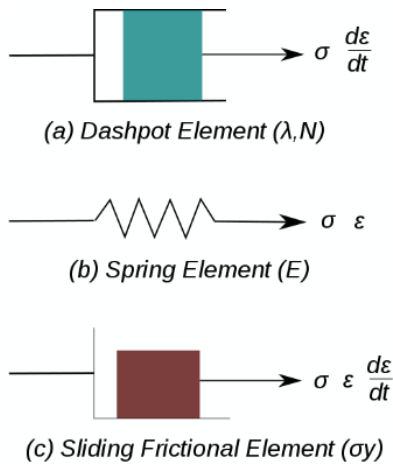

Figure 1. Elements used in one-dimensional models of viscoplastic materials.

The elastic response of viscoplastic materials can be represented in one-dimension by Hookean spring elements. Rate-dependence can be represented by nonlinear dashpot elements in a manner similar to viscoelasticity. Plasticity can be accounted for by adding sliding frictional elements as shown in Figure 1. In the figure  $E$  is the modulus of elasticity,  $\lambda$  is the viscosity parameter and  $N$  is a power-law type dashpot [ $\sigma(d\epsilon/dt) = \sigma = \lambda(d\epsilon/dt)^{1/N}$ ]. The sliding element can have a yield stress ( $\sigma_y$ ) that is strain rate dependent, or even constant, as shown in Figure 1c.

Viscoplasticity is usually modeled in three-dimensions using overstress models of the Perzyna or Duvaut-Lions types. In these models, the stress is allowed to increase beyond the rate-independent yield surface upon application of a load and then allowed to relax back to the yield surface over time. The yield surface is usually assumed not to be rate-dependent in such models. An alternative approach is to add a strain rate dependence to the yield stress and use the techniques of rate independent plasticity to calculate the response of a material.

For metals and alloys, viscoplasticity is the macroscopic behavior caused by a mechanism linked to the movement of dislocations in grains, with superposed effects of inter-crystalline gliding. The mechanism usually becomes dominant at temperatures greater than approximately one third of the absolute melting temperature. However, certain alloys exhibit viscoplasticity at room temperature

(300K). For polymers, wood, and bitumen, the theory of viscoplasticity is required to describe behavior beyond the limit of elasticity or viscoelasticity.

In general, viscoplasticity theories are useful in areas such as

- the calculation of permanent deformations,
- the prediction of the plastic collapse of structures,
- the investigation of stability,
- crash simulations,
- systems exposed to high temperatures such as turbines in engines, e.g. a power plant,
- dynamic problems and systems exposed to high strain rates.

### Phenomenology

For a qualitative analysis, several characteristic tests are performed to describe the phenomenology of viscoplastic materials. Some examples of these tests are

1. hardening tests at constant stress or strain rate,
2. creep tests at constant force, and
3. stress relaxation at constant elongation.

### Strain hardening test

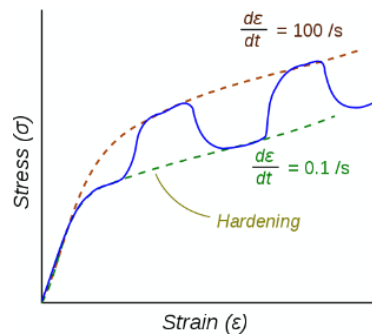

Figure 2. Stress–strain response of a viscoplastic material at different strain rates.

The dotted lines show the response if the strain-rate is held constant. The blue line shows the response when the strain rate is changed suddenly.

One consequence of yielding is that as plastic deformation proceeds, an increase in stress is required to produce additional strain. This

phenomenon is known as Strain/Work hardening. For a viscoplastic material the hardening curves are not significantly different from those of rate-independent plastic material. Nevertheless, three essential differences can be observed.

1. At the same strain, the higher the rate of strain the higher the stress.
2. A change in the rate of strain during the test results in an immediate change in the stress–strain curve.
3. The concept of a plastic yield limit is no longer strictly applicable.

The hypothesis of partitioning the strains by decoupling the elastic and plastic parts is still applicable where the strains are small, i.e.,

$$\varepsilon = \varepsilon_e + \varepsilon_{vp}$$

where  $\varepsilon_e$  is the elastic strain and  $\varepsilon_{vp}$  is the viscoplastic strain.

To obtain the stress–strain behavior shown in blue in the figure, the material is initially loaded at a strain rate of 0.1/s. The strain rate is then instantaneously raised to 100/s and held constant at that value for some time. At the end of that time period the strain rate is dropped instantaneously back to 0.1/s and the cycle is continued for increasing values of strain. There is clearly a lag between the strain-rate change and the stress response. This lag is modeled quite accurately by overstress models (such as the Perzyna model) but not by models of rate-independent plasticity that have a rate-dependent yield stress.”

### 2.3 Time-frequency analysis via fast Fourier transform

Time and frequency domain analysis of signals:

A Review by Getachew Admassie Ambaye, Faculty of Mechanical and Industrial Engineering, Bahir Dar Institute of Technology (BiT), Bahir Dar, Ethiopia.

The time domain is the analysis of mathematical functions, and physical signals with respect to time. In the time domain, the signal or function's value is known for all real numbers, in the case of continuous-time, or at various separate instants in the case of discrete-time. An oscilloscope is a tool

commonly used to visualize real-world signals in the time domain. A time-domain graph shows how a signal changes with time, whereas a frequency-domain graph shows how much of the signal lies within each given frequency band over a range of frequencies. The frequency-domain refers to the analysis of mathematical functions or signals with respect to frequency, rather than time. Put simply, a time-domain graph shows how a signal changes over time, whereas a frequency-domain graph shows how much of the signal lies within each given frequency band over a range of frequencies. A frequency-domain representation can also include information on the phase shift that must be applied to each sinusoid to be able to recombine the frequency components to recover the original time signal. And finally, the time-frequency signal analysis was introduced, it's a new method in which the problem that had on the frequency signal analysis will be solved.

#### Time-frequency analysis

Techniques and methods in signal processing (from Wikipedia)

In signal processing, the time-frequency analysis comprises those techniques that study a signal in both the time and frequency domains simultaneously, using various time-frequency. Rather than viewing a 1-dimensional signal (a function, real or complex-valued, whose domain is the real line) and some transform (another function whose domain is the real line, obtained from the original via some transform), time-frequency analysis studies a two-dimensional signal – a function whose domain is the two-dimensional real plane, obtained from the signal via a time-frequency transform.

Fourier transform (from Wikipedia):

Mathematical transform that expresses a function of time as a function of frequency.

A Fourier transform (FT) is a mathematical transform that decomposes functions depending on space or time into functions depending on the spatial frequency or temporal frequency. An example application would be decomposing the waveform of a musical chord in terms of the intensity of its constituent pitches. The term Fourier transform refers to both the frequency

domain representation and the mathematical operation that associates the frequency domain representation to a function of space or time.

**Note:** For a more detailed description, please refer to the “consolidated method” section which is given at the beginning of the special issue.

### 3. RESULTS

Figure 1 shows the data tables used in this study.

4/14/22	Viscosity 2	Viscosity 1	Viscosity 3	Viscosity 4	AS/CrI	Weight(170)	mI2	MI2	20/12/21/46	70
Liver Cancer	A1C	Weight	Lipids (m3)	MI	Norm. A1C	Norm. Weight	Norm. m3	Norm. MI	Liver Cancer	Liver Cancer %
F0000	15.0	200	1.00	1.00	1.07	1.20	1.00	1.00	1.00	76
F0001	9.0	210	0.90	1.00	1.00	1.00	0.90	1.00	1.00	60
F0002	7.5	180	0.70	0.91	1.04	1.11	0.70	0.91	1.01	50
F0003	7.0	180	0.80	0.94	1.00	1.07	0.80	0.94	1.01	51
F0004	7.0	177	0.64	0.78	1.02	1.04	0.64	0.78	0.93	46
F0005	7.7	170	0.60	0.64	1.09	1.03	0.60	0.64	0.90	45
F0006	7.0	170	0.60	0.60	1.17	1.02	0.60	0.60	0.83	41
F0007	6.9	174	0.40	0.37	1.15	1.09	0.40	0.37	0.79	40
F0008	6.8	171	0.40	0.37	1.14	1.06	0.40	0.37	0.78	39
F0009	6.7	172	0.71	0.58	1.12	1.02	0.71	0.58	0.83	41
F0010	6.3	170	0.80	0.52	1.05	1.00	0.80	0.52	0.76	38
F0011	6.1	166	0.87	0.54	1.02	0.98	0.87	0.54	0.80	40
F0012	6.2	160	0.63	0.53	1.03	0.99	0.63	0.53	0.79	40
Average	7.4	181	0.73	0.74	1.13	1.06	0.73	0.74	0.84	47

4/14/22	Strain	Viscosity 1	Viscosity 3	Viscosity 4	4/14/22	Area (A1C)	Area (Weight)	Area (Lipids)	Area (MI)	
Liver Cancer	Liver Cancer %	Stress (A1C)	Stress (Weight)	Stress (Lipids)	Stress (MI)	Liver Cancer	Area (A1C)	Area (Weight)	Area (Lipids)	Area (MI)
F0000	0	0	0	0	F0000	0	0	0	0	
F0001	80	-24	-20	-14	F0001	398	103	117	144	
F0002	50	-12	-11	-7	F0002	173	140	98	120	
F0003	52	1	1	0	F0003	-3	-3	-2	-2	
F0004	46	6	-5	-2	F0004	12	30	4	7	
F0005	40	-2	-2	-1	F0005	7	9	3	4	
F0006	41	-4	-4	-2	F0006	11	9	5	5	
F0007	40	-2	-2	-1	F0007	5	5	2	3	
F0008	39	-1	-1	0	F0008	1	1	0	0	
F0009	41	3	3	2	F0009	2	2	2	1	
F0010	38	-3	-3	-2	F0010	1	1	0	1	
F0011	40	2	2	2	F0011	-1	-1	0	-1	
F0012	40	0	0	0	F0012	0	0	0	0	
Average	57	1.3	1.2	-1.3	Average	401	108	124	137	
Stress Ratio to A1C	100%	14%	16%	15%	Area Ratio to A1C	100%	10%	10%	11%	



Figure 1: Data tables (the liver graph is courtesy of a British liver cancer article).

Figure 2 depicts 4 contribution factors of liver risk in a time domain.

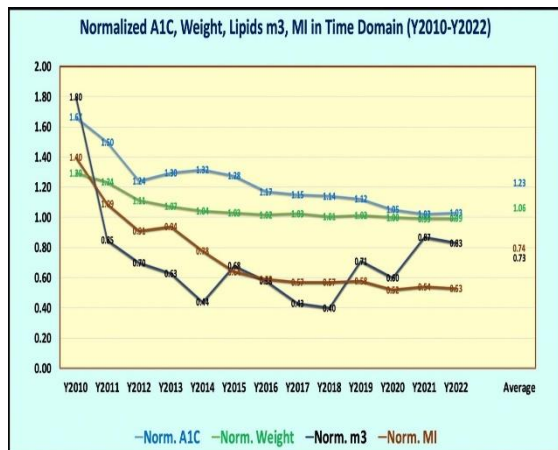

Figure 2: 4 contribution factors of liver risk in a time domain.

Figure 3 reflects the stress-strain diagram with 4 hysteresis loops via VGT analysis in a space domain.

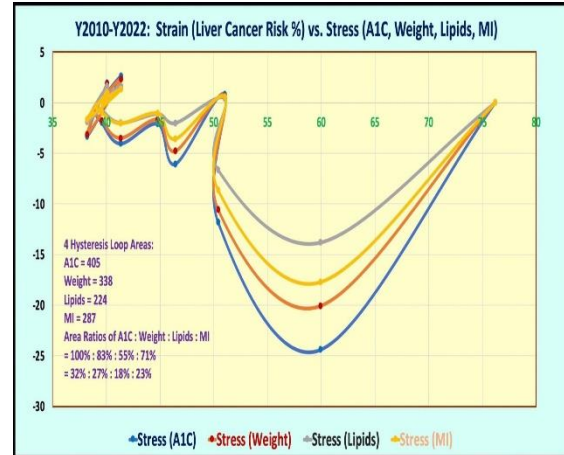

Figure 3: Stress-strain diagram with 4 hysteresis loops via VGT analysis in a space-domain.

Figure 4 illustrates the comparison of the results between the original unevenly distributed weighting factors case against the sensitivity study's evenly distributed weighting factors case.



4/14/22	Stress (A1C)	Stress (Weight)	Stress (Lipids)	Stress (MI)	Area (A1C)	Area (Weight)	Area (Lipids)	Area (MI)	Strain Rate	Avg. Liver Cancer
F100%	100%	100%	100%	100%	405	338	224	287	-2.8	44.8
F25%, 25%, 25%, 25%	100%	100%	100%	100%	464	387	260	332	-2.7	47.1
A/B	100%	100%	100%	100%	87%	87%	86%	87%	100%	99%

Figure 4: Comparison between the original case against the sensitivity study case.

### 4. CONCLUSION

In summary, the following five described biophysical characteristics have demonstrated certain key behaviors of his

liver cancer risk study using the VGT approach:

(1) From the display of 4 influential factors in a time-domain (TD), his A1C has decreased from a severe diabetes condition of 10% to around 5.8% in 2022 (pre-diabetes and near-normal condition without any medication intervention after 2016). His body weight has reduced from an obese condition of 220 lbs. (BMI 32) to 169 lbs. in 2022 (BMI 24.95, a normal weight condition). His lipids (m3) condition has dropped from hyperlipidemia of 1.80 in 2010 and 0.85 in 2011 to below 0.735 after 2012, and 0.83 in 2022 (fluctuating borderline lipid conditions). His overall metabolism index (MI) value started at 1.40 in 2010 and has been gradually lowered to below 0.735 after 2015 and now reach 0.53 in 2022. This shows the results of his stringent lifestyle management program are working to improve his chronic conditions control. As mentioned before, he has not had any chronic inflammation, or hepatitis B and C infections, and he does not drink alcohol at all.

(2) From the stress-strain hysteresis loops of VGT analysis in a space-domain, the right half of the first 4-year curves (Y2010-Y2013) have larger differences among these 4 influential curves which can also be observed from the corresponding time-domain curves. However, the left half of the following 8+ year curves (Y2014-Y2022) have close proximity among these 4 influential curves that can be seen from the corresponding time-domain curves. However, in general, the visual check of the y-axis scale ranking is in the order of "A1C, Weight, MI, and lipids". This ranking order is also similar to the stress value and the hysteresis loop area size rankings.

(3) The hysteresis loop areas are 405 for A1C, 338 for weight, 287 for MI, and 224 for lipid m3. The data provides an area ratio of 1.0 : 0.83 : 0.71 : 0.55 for A1C : Weight : MI : lipids m3; or 32% : 27% : 23% : 18% if using 100% as the base. It shows that the control effort on his HbA1C (T2D), weight (obesity or overweight), and MI (management of 6 lifestyles and 4 chronic diseases) has been successful, but he needs to put more effort

into his lipids management to get a better result.

(4) His liver cancers risk (strain) equation is: "0.3 \* normalized A1C (A1C / 6.0) + 0.15 \* normalized body weight (weight / 170) + 0.15 \* normalized lipids + 0.4 \* normalized MI". His calculated liver cancer risk % was at a relative level of 76% in Y2010 and continuously dropped to 40% in Y2022 (only 3+ months of data available). It should be emphasized that all of the risk percentages are relative numbers, not absolute numbers. This observation proves that his Liver cancer risk % is being reduced by almost half (~50%) from a relatively higher level of 76% in 2010 down to a relatively lower level of 40% in 2022 through his stringent lifestyle management program.

(5) In order to understand his liver cancer risk deeper, he conducted a sensitivity analysis by using another defined equation for his liver cancer risk %: "0.25 \* normalized A1C (A1C / 6.0) + 0.25 \* normalized body weight (weight / 170) + 0.25 \* normalized lipids + 0.25 \* normalized MI". The ending results from this evenly distributed weighting factors case are very close to the results from the original unevenly distributed weighting factors.

This article has demonstrated how the author utilizes the physics and engineering, VGT methodology, to construct and display his research result findings of liver cancer risk % via time-domain waves and space-domain stress-strain curves.

## 5. REFERENCES

For editing purposes, the majority of the references in this paper, which are self-references, have been removed. Only references from other authors' published sources remain. The bibliography of the author's original self-references can be viewed at [www.eclaircmd.com](http://www.eclaircmd.com).

Readers may use this article as long as the work is properly cited, their use is educational and not for profit, and the author's original work is not altered.

# Viscoelastic and Viscoplastic Glucose Theory Application in Medicine

Gerald C. Hsu

