

The GH-Method

Viscoelastic or Viscoplastic Glucose Theory (VGT #63): A Summary Report on the Annual Relative Risks of Developing Pancreatic, Liver, and Various Cancers Using Various Influential Factors such as HbA1C, Glucose, Insulin Resistance, Lipids, Weight, Diet, Walking Steps, and Metabolism Index from the Collected Data of a Type 2 Diabetes Patient Over an ~12+ Years Period Based on GH-Method: Math-Physical Medicine (No. 651)

Gerald C. Hsu*

eclairMD Foundation, USA

Keywords: Viscoelastic; Viscoplastic; Pancreatic cancer; Liver cancer; Type 2 diabetes; HbA1C; Glucose; Insulin resistance; Lipids; Weight; Diet; Walking steps; Metabolism index; Fasting plasma glucose; Postprandial plasma glucose

Abbreviations: T2D: type 2 diabetes; SD: space domain; TD: time domain; MI: metabolism index; PPG: postprandial plasma glucose; FPG: fasting plasma glucose; MPM: math-physical medicine

1. INTRODUCTION

From July 2021, the author read a consensus report published jointly by the American Diabetes Association and the American Cancer Society in 2010 regarding relationships between cancers and diabetes. Based on his learned knowledge from the article and 2+ million collected data of his overall metabolism, including medical conditions and lifestyle details, he conducted a few cancer research studies regarding his estimated relative risk percentages of developing pancreatic, liver, and various cancers during the past 12+ years from 1/1/2010 to 4/15/2021. This article is a combination of his four papers No. 584, 617, 649, and 650.

This study contains four viscoplastic models using respective influential factors as described:

(1) No. 649 - Pancreatic cancer using hyperglycemia, insulin resistance, obesity, chronic inflammation, and metabolism index.

(2) No. 650 - Liver cancer using HbA1C, obesity, blood lipids, and metabolism index.

(3) No. 617 - Various cancers using combined scores of 4 medical conditions, and a combined score of 6 lifestyle details.

(4) No. 651 - Various cancers using HbA1C for diabetes, body weight for obesity, diet score for food quantity and quality, and daily walking steps for physical activity.

The author utilized some carefully selected dividing-line numbers to separate a health condition versus an unhealthy condition:

(1) Type 2 diabetes (T2D) conditions expressed by HbA1C values (A1C 6.0 is used as the dividing line),

(2) Obesity or being overweight expressed by body weight (170 lbs. as the dividing line for his BMI at 25.0),

- (3) Lipids are expressed by the m3 value (m3 is an averaged combination score of LDL, HDL, TG, and total cholesterol which uses 0.735 or 73.5% as the dividing line),
- (4) Postprandial plasma glucose (PPG) above 180 mg/dL for defining hyperglycemia,
- (5) Fasting plasma glucose (FPG) above 180 mg/dL for estimating the insulin resistance condition,
- (6) Metabolism index value or MI value (a combined score of 4 medical conditions and 6 lifestyle details) uses 0.735 or 73.5% as the dividing line.
- (7) In addition to these 6 important influential factors, other factors influence cancers, such as alcohol intake, tobacco smoking, illicit drug use, hepatitis B and C infection, chronic inflammation, viral infections, and multiple environmental influences (radiation, toxin, pollution, hormonal therapy, etc.) and certain diabetes medications (e.g., metformin and insulin). However, these additional factors do not apply to the author's case since he does not have any lifetime unhealthy habits, known severe environmental exposures, or the above-mentioned medical conditions. In fact, he has never taken insulin and ceased all three diabetes medications on 12/8/2015.

The dividing-line numbers are used as individual normalization factors in his VGT study to normalize all of the influential factors. Normalization aims to bring the influential factors to the same baseline based on different biomedical considerations. If he uses the original biomarker values such as mg/dL for glucose and lbs. for weight, it will distort the y-axis values or the stress values in the calculations and therefore affect the hysteresis loop area sizes accordingly. As a result, it could make the influential factors or damage assessment (or the degree of influences on cancers) through the VGT energy more difficult.

This study focuses on his own cancer risk probability percentages based on the collected data over 12+ years from 1/1/2010 to 4/15/2022; therefore, it is necessary to provide a brief description of his health history.

The author was diagnosed with T2D in 1997 with a random glucose check at a 300 mg/dL level; however, his T2D condition most likely began earlier. He suffered his first two chest pain episodes in 1993-1994 and three more heart episodes until 2007. His primary physician informed him that he had diabetic kidney issues in 2010. He then consulted with two more clinical doctors who advised him to immediately start insulin injections and kidney dialysis. This was his wake-up call. He then decided to cease all of his business operations and started to save his own life by conducting his self-study and research on food nutrition and chronic diseases that same year. His health profile in 2010 was: body weight at 220 lbs. (BMI 32), average daily glucose at 280 mg/dL, fasting plasma glucose (FPG) in the early morning at 180 mg/dL, lab-tested HbA1C at 10%, triglycerides at 1160, and his ACR at 116.

During the past 13 years, he has made significant lifestyle changes. For example, he consumes less than 20 grams of carbohydrates and sugar per meal (low carbs, low fat, high protein, rich fresh vegetable meals), avoids processed foods, reduces his food quantity by 50% from the original consumed amount, walks 6-7 miles or 10-11 kilometers daily and 4000+ steps after each meal, sleeps 7-8 hours each night, and reduces stress as much as possible. He also steers clear of taking unnecessary medications (chemical compounds). In his lifetime, he has never drunk alcohol, smoked cigarettes, or used any illicit drugs.

As of April 10, 2022, his health profile for the first 3 months is body weight of 169 lbs. (BMI 24.95), daily average glucose at 106 mg/dL, FPG in the early morning at 94 mg/dL, lab-tested A1C at 5.8%, triglycerides at 108, and ACR at 16. This is a significant accomplishment because he discontinued 3 different kinds of diabetes medications on 12/8/2015. Fortunately, he has not detected any sign of cancer to date.

Relationships between biomedical causes and biomedical symptoms:

As a mathematician/engineer for over 40 years and then conducting his medical research work during the past 13 years, the author has discovered that people frequently seek answers, illustrations, or explanations for the relationships between the input

variable (force applied on a structure or cause of a disease) and output variable (deformation of a structure or symptom of a disease). However, the multiple relationships between input and output could be expressed with many different matrix formats of 1×1 , $1 \times n$, $m \times 1$, or $m \times n$ (m or n means different multiple variables). In addition to these described mathematical complications, the output resulting from one or more inputs can also become an input of another output, which is a symptom of certain causes that can become a cause of another different symptom. This phenomenon is indeed a complex scenario with “chain effects”. In fact, both engineering and biomedical complications are fundamentally mathematical problems that correlate or conform with many inherent physical laws or principles. Over the past 13 years, in his medical research work, he has encountered more than 100 different sets of biomarkers with almost equal or more amounts of causes (or input variables) and symptoms (or output variables).

Viscoelasticity/plasticity research:

Since December of 2021, the author applied theories of viscoelasticity and viscoplasticity (VGT) from physics and engineering disciplines to investigate more than 60 sets of input/output biomarkers. The purpose is to identify certain hidden relationships between certain output biomarkers, such as cancer risk, and its corresponding multiple inputs or influential factors. In this study, the hidden biophysical behaviors and possible inter-relationships among the output symptom and multiple input causes are “time-dependent” and change from time to time. These important time-dependency characteristics provide insight into different types of cancer risk’s moving patterns. It also controls the cancer risk curve shape, the associated energy (or degree of influences) created, stored, or burned inside during the process of stress up-loading (influential factor’s moving upward or increasing) and stress down-loading (influential factor’s moving downward or decreasing) and its relationship with the output biomarker of cancer risk %. VGT applications emphasize the time-dependency characteristics of involved variables. In the medical field, most biomarkers are time-dependent since body organ cells are organic in nature and change all of the time. Incidentally, VGT can generate the stress-strain curve, or the cause-

symptom curve, known as a “hysteresis loop” in physics, in which area size can also be used to estimate the relative energy or degree of influence, created, stored, or burned during the process of uploading (e.g. increasing glucose) and unloading (e.g. decreasing body weight) over the timespan of a particular cancer risk %. He calls this relative energy the “VGT energy”.

It should be emphasized here that both cancer risk percentage and its associated VGT energy values (i.e. contribution to cancer prognosis by influential factors) are estimated “relative” values, not “absolute” values.

The following defined stress and strain equations are used to establish the VGT stress-strain diagram in a space domain (SD):

VGT strain
 $= \varepsilon$ (symptom)
 $=$ individual symptom at the present time

VGT stress
 $= \sigma$ (based on the change rate of strain, symptom, multiplying with one or more viscosity factors or influential factors)
 $= \eta * (d\varepsilon/dt)$
 $= \eta * (d\text{-strain}/d\text{-time})$
 $=$ (viscosity factor η using normalized factor at present time) * (symptom at present time - symptom at a previous time)

Where the strain is the cancer risk percentage and the stress is his cancer risk change rate multiplied by preferred input biomarkers as individual viscosity factors. In his VGT studies, at times, he carefully selects certain normalization factors for individual input biomarkers, respectively. In general, he uses the normalization factors from the dividing line values between a healthy state and an unhealthy state. For example, 170 lbs. for body weight, 6.0 for HbA1C, 120 mg/dL for glucose, 180 mg/dL for hyperglycemia, and 73.5% for medical conditions of lifestyle detail of overall MI score.

To offer a simple explanation to readers who do not have a physics or engineering background, the author includes a brief excerpt from Wikipedia regarding the description of basic concepts for elasticity and plasticity theories, viscoelasticity, and viscoplasticity theories from the disciplines of engineering and physics in the Methods

section. In addition, he has also described his mathematical MI model in detail in the same methods sections.

General information on cancers:

The consensus report of cancer and diabetes:

The following is a rather long excerpt (~2,419 words) from the Reviews/Commentaries/ADA Statements, "Diabetes and Cancer, A consensus report" by Edward Giovannucci, MD, and other authors, published by the American Diabetes Association and the American Cancer Society. The original paper has more than 8,000 words without counting its 123 references. The author considers this paper a trove of knowledge; therefore, he has kept ~30% of its original words in this excerpt for his future easy access.

"Diabetes and cancer are common diseases with tremendous impact on health worldwide. Epidemiologic evidence suggests that people with diabetes are at significantly higher risk for many forms of cancer. Type 2 diabetes and cancer share many risk factors, but potential biologic links between the two diseases are incompletely understood. Moreover, evidence from observational studies suggests that some medications used to treat hyperglycemia are associated with either increased or reduced risk of cancer. Against this backdrop, the American Diabetes Association and the American Cancer Society convened a consensus development conference in December 2009. Following a series of scientific presentations by experts in the field, the writing group independently developed this consensus report to address the following questions:

1. Is there a meaningful association between diabetes and cancer incidence or prognosis?
2. What risk factors are common to both diabetes and cancer?
3. What are possible biologic links between diabetes and cancer risk?
4. Do diabetes treatments influence the risk of cancer or cancer prognosis?

1. Is there a meaningful association between diabetes and cancer incidence or prognosis?

Both diabetes and cancer are prevalent diseases whose incidence is increasing globally. Worldwide, the prevalence of cancer has been difficult to establish because many

areas do not have cancer registries, but in 2008 there were an estimated 12.4 million new cancer cases diagnosed. The most commonly diagnosed cancers are lung/bronchus, breast, and colorectal, whereas the most common causes of cancer deaths are lung, stomach, and liver cancer (1). In the U.S., the most commonly diagnosed cancers are prostate, lung/bronchus, and colon/rectum in men and breast, lung/bronchus, and colon/rectum in women. Of the world population between the ages of 20 and 79 years, an estimated 285 million people, or 6.6%, have diabetes (2). In 2007, diabetes prevalence in the U.S. was 10.7% of persons aged 20 years and older (23.6 million individuals), with an estimated 1.6 million new cases per year. Type 2 diabetes is the most common form, accounting for ~95% of prevalent cases (3). Worldwide, cancer is the 2nd, and diabetes is the 12th leading cause of death (4). In the U.S., cancer is the 2nd and diabetes is the 7th leading cause of death; Cancer and diabetes are diagnosed within the same individual more frequently than would be expected by chance, even after adjusting for age. Both diseases are complex with multiple subtypes. Diabetes is typically divided into two major subtypes, type 1 and type 2 diabetes, along with less common types, while cancer is typically classified by its anatomic origin (of which there are over 50, e.g., lymphoma, leukemia, lung, and breast cancer) and within which there may be multiple subtypes (e.g., leukemia). Further, the pathophysiologies underlying both cancer and diabetes are (with rare exceptions) incompletely understood.

For more than 50 years, clinicians have reported the occurrence of patients with concurrent diabetes and cancer. However, as early as 1959, Joslin et al. (5) stated, "Studies of the association of diabetes and cancer have been conducted over a period of years, but evidence of a positive association remains inconclusive." Subsequently, an association between the two diseases was identified in the 1960s in population-based studies. More recently, the results of several studies have been combined for meta-analytic study (6), indicating that some cancers develop more commonly in patients with diabetes (predominantly type 2), while prostate cancer occurs less often in men with diabetes. The relative risks imparted by diabetes are greatest (about twofold or higher) for cancers

of the liver, pancreas, and endometrium, and lesser (about 1.2–1.5 fold) for cancers of the colon and rectum, breast, and bladder. Other cancers (e.g., lung) do not appear to be associated with an increased risk in diabetes, and the evidence for others (e.g., kidney, non-Hodgkin lymphoma) is inconclusive.

Diabetes-related factors including steatosis, nonalcoholic fatty liver disease, and cirrhosis may also enhance susceptibility to liver cancer. With regard to pancreatic cancer, interpretation of the causal nature of the association is complicated by the fact that abnormal glucose metabolism may be a consequence of pancreatic cancer (so-called “reverse causality”). However, a positive association between diabetes and pancreatic cancer risk has been found when restricted to diabetes that precedes the diagnosis of pancreatic cancer by at least 5 years.

Only for prostate cancer is diabetes associated with a lower risk. This association has been observed both before and after the advent of screening with prostate-specific antigen (PSA). Some metabolic factors associated with diabetes, such as reduced testosterone levels, may be involved. While obesity has not been associated, and in some studies is even inversely associated, with prostate cancer incidence, obese men with prostate cancer have higher cancer mortality rates than those of normal weight (7). In addition to metabolic factors such as hyperinsulinemia, obesity may be associated with clinical factors (such as delayed diagnosis, poorer treatment) that may underlie the worsened prostate cancer prognosis.

Results of some, but not all, epidemiological studies suggest that diabetes may significantly increase mortality in patients with cancer (8).

Unanswered questions

Diabetes has been consistently associated with increased risk of several of the more common cancers, but for many, especially the less common cancers, data are limited or absent (6) and more research is needed. Uncertainty is even greater for the issue of diabetes and cancer prognosis or cancer-specific mortality. It remains unclear whether the association between diabetes and cancer is direct (e.g., due to

hyperglycemia), whether diabetes is a marker of underlying biologic factors that alter cancer risk (e.g., insulin resistance and hyperinsulinemia), or whether the cancer-diabetes association is indirect and due to common risk factors such as obesity.

In view of the variable associations between diabetes and cancer risk at specific sites, the authors discourage studies exploring links between diabetes and risk of all cancers combined. For example, since lung cancer does not appear to be meaningfully linked with diabetes, including this common cancer in studies will dilute observed associations, should they exist.

2. What risk factors are common to both cancer and diabetes?

Potential risk factors (modifiable and nonmodifiable) common to both cancer and diabetes include aging, sex, obesity, physical activity, diet, alcohol, and smoking.

Nonmodifiable risk factors

Age

Although the incidence of some cancers peaks in childhood or in young adults, the incidence of most cancers increases with age. In economically developed countries, 78% of all newly diagnosed cancer occurs among individuals aged 55 years and older (11). Diabetes also becomes increasingly common with age: Prevalence is 2.6% in U.S. adults 20–39 years of age, 10.8% in those 40–59 years of age, and increases to 23.8% in those 60 years of age or older (3). In parallel with the obesity epidemic, type 2 diabetes is becoming more frequent among adolescents and young adults (12,13), potentially adding years of additional risk from diabetes to the population.

Sex

While certain cancers are sex-specific (e.g., cervix, uterine, testicular, prostate), or nearly so (breast), overall cancer occurs more frequently in men. Men have slightly higher age-adjusted risk of diabetes than women (3).

Race/ethnicity

In the U.S., African Americans are more likely to develop and die from cancer than

other race or ethnic groups. Following African Americans are non-Hispanic whites, with Hispanics, Native Americans, and Asian Americans/Pacific Islanders having lower cancer incidence and mortality (14). While incompletely understood, genetic, socioeconomic, lifestyle, and other environmental factors are thought to contribute to these disparities.

Modifiable risk factors

Overweight, obesity, and weight change

Overweight (BMI ≥ 25 and < 30 kg/m²) or obese (BMI ≥ 30 kg/m²) individuals have a higher risk for many types of cancer compared with individuals whose BMI is considered within the normal range (18.5 to < 25 kg/m²) (16,17). The cancers most consistently associated with overweight and obesity are breast (in postmenopausal women), colon/rectum, endometrium, pancreas, adenocarcinoma of the esophagus, kidney, gallbladder, and liver. Obesity may also increase risk of mortality from some cancers, such as prostate (7). A growing body of evidence suggests that weight gain is associated with an increased risk of some cancers, breast cancer in particular (17). Increases in body weight during adulthood largely reflect increases in adipose tissue rather than lean mass, so total body fat may be a better measure of the risk for cancer than BMI.

Studies over decades have consistently shown a strong association between obesity and both insulin resistance and type 2 diabetes incidence (18), with risk of diabetes and earlier age at onset directly linked to obesity severity (19). For type 2 diabetes (20) as well as certain cancers (e.g., colon) (21), some studies suggest that waist circumference, waist-to-hip ratio, or direct measures of visceral adiposity are associated with risk independently of BMI.

The case for a causal relationship between obesity and disease is strengthened by evidence that weight loss lowers disease risk. In the randomized, prospective, multicenter Diabetes Prevention Program trial, an intensive lifestyle intervention of diet (targeting 5–7% weight loss) and physical activity was associated with a 58% reduction in diabetes incidence in high-risk individuals (22), and weight loss accounted for most of

the effect (23). In addition, weight loss may also limit the risk of developing gestational diabetes (24).

The association between weight loss and subsequent cancer risk is less clear. Weight loss may be a sign of undiagnosed cancer.

Diet

A majority of studies suggest that diets low in red and processed meats and higher in vegetables, fruits, and whole grains are associated with a lower risk of many types of cancer (17,28,29). Diets that are low in red and processed meat but high in monounsaturated fatty acids, fruits, vegetables, whole grain cereals, and dietary fiber may protect against type 2 diabetes, possibly through improving insulin sensitivity (30,31). Low-carbohydrate diets (which often include greater consumption of red meats and fat) have also been associated with weight loss and improvements in insulin sensitivity and glycemic control. However, randomized controlled trial evidence of dietary interventions and diabetes prevention only exists for low-fat, low-calorie, plus/minus high-fiber diets (22,32).

Several studies suggest that diets high in foods with a high glycemic index or load are associated with an increased risk of type 2 diabetes (28,33). However, evidence of their associations with cancer risk is mixed (28,34,35). Regardless, to the extent that energy-dense and sugary foods contribute to overweight and obesity, the American Cancer Society, the World Cancer Research Fund, and the American Institute for Cancer Research recommend limiting consumption of these foods (17,29).

Physical activity

Evidence from observational epidemiologic studies consistently shows that higher levels of physical activity are associated with a lower risk of colon, postmenopausal breast, and endometrial cancer (17,36,37). Physical activity may also help prevent other cancers, including lung and aggressive prostate cancer, but a clear link has not been established. Some evidence also suggests that physical activity post-diagnosis may improve cancer survival for some cancers, including breast (38) and colorectal (39).

A protective role for increased physical activity in diabetes metabolism and outcomes has been demonstrated. Data from observational and randomized trials suggest that ~30 min of moderate-intensity exercise, such as walking, at least 5 days per week substantially reduces (25–36%) the risk of developing type 2 diabetes (40).

Tobacco smoking

It is estimated that worldwide, tobacco smoking accounts for 71% of all trachea, bronchus, and lung cancer deaths (41). Other cancers strongly associated with smoking are larynx, upper digestive, bladder, kidney, pancreas, leukemia, liver, stomach, and uterine cervix.

Alcohol

Alcoholic beverage consumption, even in moderate amounts, increases the risk of many types of cancer including those of the oral cavity, pharynx, larynx, esophagus, liver, colon/rectum, and female breast (45).

Unanswered questions

A critical question is whether the associations between diabetes and risk of certain cancers is largely due to shared risk factors (obesity, poor diet, physical inactivity, and aging), or whether diabetes itself, and the specific metabolic derangements typical of diabetes (e.g., hyperglycemia, insulin resistance, hyperinsulinemia), increase the risk for some types of cancer. While it is clear that lower levels of adiposity, healthy diets, and regular physical activity are associated with reduced risk for type 2 diabetes and for several common types of cancer, these factors are generally interrelated, making the contribution of each factor difficult to assess.

3. What are possible biologic links between diabetes and cancer risk?

Carcinogenesis is a complex process. Normal cells must undergo multiple genetic “hits” before the full neoplastic phenotype of growth, invasion, and metastasis occurs. This process of malignant transformation can be divided into multiple steps: initiation (irreversible first step toward cancer), promotion (stimulation of the growth of initiated cells), and progression (development

of a more aggressive phenotype of promoted cells).

Hyperglycemia and cancer

In considering the complexity of interactions between diabetes, diabetes treatments, and cancer, it is important to not overlook glucose as a potentially relevant mediator. The recent resurgence of interest in the Warburg hypothesis and cancer energetics (66) emphasizes the dependence of many cancers on glycolysis for energy, creating a high requirement for glucose (or even “glucose addiction”).

Insulin receptor activation may be a more important variable than hyperglycemia in determining tumor growth.

Major unanswered questions

As previously outlined, there is a growing body of epidemiologic evidence supporting a link between diabetes and the incidence and/or prognosis of some cancers. It is recognized the association may not be causal; diabetes and cancer may be associated simply because they share common predisposing risk factors such as obesity.

Individuals with type 1 diabetes represent ~5% of the diabetes population worldwide. The autoimmune destruction of the pancreatic β -cells results in the loss of insulin production and the need for immediate and lifelong insulin therapy. In contrast, type 2 diabetes is much more common and accounts for ~95% of the diabetes population. Type 2 diabetes is generally associated with overweight and obesity (in an estimated 80% of cases) and commonly advances from a pre-diabetic state characterized by insulin resistance (hyperinsulinemia) to frank diabetes with sustained insulin resistance accompanied by a progressive reduction in insulin secretion.

Insulin and insulin analogs

Insulin is required for all patients with type 1 diabetes. It is also necessary for many patients with type 2 diabetes to treat hyperglycemia, in part due to the progressive loss of β -cell function over time. Between 40–80% of individuals with type 2 diabetes will ultimately be considered for insulin therapy in an effort to achieve glycemic targets (77).”

Interpreted key points of the ADA/ACS consensus report:

After reading the report six times, the author attempts to derive some conclusive learning for his study.

(1) Cancers and diabetes have some statistical links but their biological relationships are still inconclusive. Diabetes has been consistently associated with increased risk for several of the more common cancers, but they are not for all different types of cancer. Although the pathophysiologies underlying both cancer and diabetes are incompletely understood with rare exceptions, the identification of some “clear and detailed” connections between cancers and various metabolic disorders are also incomplete. However, at least, we have already identified some common risk factors between diabetes and cancers, particularly in the areas of lifestyle details and life-long unhealthy habits, i.e. in the area of root causes.

(2) It seems that insulin resistance (hyperinsulinemia) has some influences on cancer. Diabetic hyperglycemia is also the direct result of insulin resistance. Therefore, it warrants to focus on the case with both hyperglycemia and insulin resistance which warrants having an emphasized or more weighted input.

(3) Diets that are low in red and processed meat but high in monounsaturated fatty acids, fruits, vegetables, whole grain cereals, and dietary fiber may protect against T2D, possibly by improving insulin sensitivity. Furthermore, low-carbohydrate diets have also been associated with weight loss and improvements in insulin sensitivity and glycemic control. These findings have provided the significance of the qualities of food on cancers as well.

(4) There is no doubt about the obvious link existing between cancers and lifestyle details or life-long unhealthy habits, especially diet (particularly food quality, including types of food, processed food, food additives, etc.), physical exercise, sleep, and stress. For example, the shared risk factors for certain cancers and diabetes are obesity (related to food quantity), poor diet (i.e., food quality), physical inactivity, and aging. Exercise and

sleep have been proven to be important for both health and the healing process. The author also self-studied psychology and psychiatry for 9 years; therefore, he understands the importance of stress on our overall physical health. These lifestyle details with assigned more weights serve as a part of the basis of his study. Life-long unhealthy habits, such as tobacco smoking, excessive alcohol drinking, and illicit drug use can eventually cause cancers and many other conditions.

(5) Body weight, especially being obese or overweight, is a strong influence factor on both diabetes and cancer development. Since food portion or food quantity directly contributes to being overweight or obese; therefore, body weight can include food quantity together for the analysis.

(6) Other metabolic biomarkers, such as blood lipids and blood pressure (BP), are important for developing various metabolic disorders & diabetic complications, including cardiovascular disease (CVD), congenital heart disease (CHD), stroke, chronic kidney disease (CKD), diabetic retinopathy (DR), neuropathy, etc. However, the direct connection between BP/lipid and cancers is generally inconclusive, except for a few special cases, such as pancreatic cancer. It has been proven by a Japanese doctor that high triglycerides indeed have a strong association with prostate cancer for 60+-year-old males.

(7) Given the variable associations between diabetes and cancer risk for certain specific cases, the authors of the consensus report discourage studies exploring links between “diabetes” and the risk of all cancers combined. However, the author of this paper wants to conduct his research on exploring links between “metabolism” and the risk of all cancers combined, since we have already learned that metabolism and immunity are the two fundamental cornerstones of our overall health, including cancers.

(8) In the consensus report on diabetes and cancers, the original paper’s authors have repeatedly used the phrases like: “lacking of epidemiological evidence, having incomplete biological links, or facing unclear pathophysiologies underlying the association between diabetes and cancers directly”. This caused the author of this paper to reflect on

the meaning of these statements deeper using his academic background in both physics and engineering. Although various cancers have their respective causes and diabetes has its own specific causes, but the majority of these causes indeed overlap with each other. To identify the direct relationship between diabetes and cancers based on symptoms which is more unclear or even difficult, it may be easier to start with researching their overlapped or common root causes, e.g. lifestyle, life-long unhealthy habits, certain environmental factors, such as toxins, pollution, and radiation, and overall metabolism state, including chronic diseases and lifestyle details. This situation can be illustrated using the author's engineering and physics background. The tensile stress (stretching force) and strain (longitudinal deformation) are dependent on Young's modulus, while the shear stress (shear force) and strain (shear deformation) are dependent on the shear modulus. These two situations require two separated defined equations. However, both Young's modules (similar to the relationship of the cancer between their causes and symptoms) and shear modules (similar to the diabetes relationship between its causes and symptoms) are directly related to the actual material of the study subject, such as steel. The engineering material contains certain engineering modules, such as Young's modulus and shear modulus. Human body conditions are under the influence of many root-causes, such as lifetime unhealthy habits, lifestyle details, environmental factors, and metabolism state. Likewise, human body also contains certain "biomedical modules" which connecting root-case and symptom together, like the engineering material case. Therefore, we need to start with a good understanding of the human body's "material" first (i.e., the underlying root-causes), instead of focusing on the symptoms comparison directly.

In the author's personal opinion, this is the major shortcoming of this consensus report.

2. METHODS

2.1 Metabolism index model

This model was developed in Y2014 by the author using the topology concept, nonlinear algebra, geometric algebra, and engineering

finite element method. In summary, the human body metabolism is a complex mathematical problem with a matrix format of m causes by n symptoms.

This MI model contains ten specific categories, including four output categories of medical conditions (body weight, glucose, blood pressure, and lipids), and six input categories of lifestyle details (food quantity and quality, drinking water intake, physical exercise, sleep, stress, and daily life routines). These 10 categories are comprised of approximately 500 detailed elements. He has also defined two new resulting parameters: the metabolism index or MI, as the combined score of the above 10 metabolism categories and 500 elements using his developed algorithm, along with the general health status unit (GHSU), as the 90-days moving average value of MI.

A physical analogy of this mathematical metabolism model is similar to "using multiple nails that are encircled by many rubber bands". For example, at first, we hammer 10 nails into a piece of flat wood with an initial shape of a circle, then take 3,628,800 ($=10!$) rubber bands to encircle the nails, including all 10 nails. These ~3.6 million rubber bands (i.e. big number of relationships) indicate the possible relationships existing among these 10 nails (i.e. 10 original metabolism data). Some rubber bands encircle 2 nails or 3 nails and so on until the last rubber band encircles all of these 10 nails together (no rubber band to encircle a single nail is allowed). Now, if we move any one of the nails outward (i.e., moving away from the center of the nail circle), then this moving action would create some internal tension inside the encircled rubber band. Moving one nail "outward" means one of these ten metabolism categories is becoming "unhealthy" which would cause some stress to our body. Of course, we can also move some or all of the 10 nails outward at the same time, but with different moving scales. If we can measure the summation of the internal tension created in the affected rubber bands, then this summarized tension force is equivalent to the metabolism value of human health. The higher tension means a higher metabolism value which creates an unhealthy situation. The author uses the above-described scenario of moving nails and their encircled rubber bands to explain his

developed mathematical metabolism model of human health.

During 2010 and 2011, the author collected sparse biomarker data, but from the beginning of 2012, he has been gathering his body weight and finger-piercing glucose values each day. More complete data collection started in Y2015. In addition, he accumulates medical conditions data including BP, heart rate (HR), and blood lipids along with lifestyle details (LD). Since 2020, he has added the daily body temperature and blood oxygen level due to his concerns about being exposed to COVID-19. Based on the collected big data of biomarkers, he further organized them into two main groups. The first is the medical conditions group (MC) with 4 categories: weight, glucose, BP, and blood lipids. The second is the lifestyle details group (LD) with 6 categories: food & diet, exercise, water intake, sleep, stress, and daily routines. At first, he calculated a unique combined daily score for each of the 10 categories within the MC and LD groups. The combined scores of the 2 groups, 10 categories, and 500+ detailed elements constitute an overall “metabolism index (MI) model”. It includes the root-causes of 6 major lifestyle inputs and symptoms from 4 lifestyle induced rudimentary chronic diseases, i.e. obesity, diabetes, hypertension, and hyperlipidemia. Therefore, the MI model, especially its 4 chronic disease conditions, can be used as the foundation and building block for his additional research work that can expand into various complications associated with different organs, such as cancer. Of course, the same methodology can be extended to the study of many other medical complications, such as various heart problems (CVD & CHD), stroke, neuropathy, hypothyroidism, diabetic constipation, diabetic skin fungal infection, various cancers, and dementia.

Some genetic conditions and lifetime unhealthy habits, which include tobacco smoking, alcohol drinking, and illicit drug use, account for approximately 15% to 25% of the root-cause of chronic diseases and their complications, as well as cancers and dementia. His calculated risk probability % for CKD, CVD, DR, stroke, and various cancers have some differences in their root-cause variables, their associated weighting factors for each key cause, and certain biomedical assumptions. Specifically, the

CVD/Stroke risk includes two major scenarios that combine emphasized weighting factors, blood vessel blockage due to blood glucose and blood lipids, and blood vessel rupture caused by blood glucose and blood pressure. Some recent research work has identified the relationship between pancreatic cancer with hyperglycemia and insulin resistance phenomena of T2D, and inflammation. There is also evidence of a relationship between BP and DR (Reference: BP control and DR, by R. Klein and BEK Klein from British Journal of Ophthalmology). The CKD risks include hyperglycemic damage to micro-blood vessels and nerves which causes protein leakage found in urine and waste deposit within the kidneys; therefore, it requires dialysis to remove waste products and excess fluids from the body. However, the cancer risk also consists of additional influences from environmental conditions, such as improper medications, viral infections, food pollution or poison, toxic chemical, radiation, air and water pollution, hormonal treatment, etc.

All of the above-mentioned diseases fall into the category of “symptoms” which are the outcomes of “root causes” of genetic conditions, unhealthy lifestyles, and poor living environments.

2.2 Elasticity, plasticity, viscoelasticity, and viscoplasticity

The difference between elastic materials and viscoelastic materials (from “Soborthans, innovating shock and vibration solutions”).

What are elastic materials?

Elasticity is the tendency of solid materials to return to their original shape after forces are applied on them. When the forces are removed, the object will return to its initial shape and size if the material is elastic.

What are viscous materials?

Viscosity is a measure of a fluid’s resistance to flow. A fluid with large viscosity resists motion. A fluid with low viscosity flows. For example, water flows more easily than syrup because it has a lower viscosity. High viscosity materials might include honey, syrups, or gels – generally things that resist flow. Water is a low viscosity material, as it flows readily. Viscous materials are thick or

sticky or adhesive. Since heating reduces viscosity, these materials don't flow easily. For example, warm syrup flows more easily than cold.

What is viscoelastic?

Viscoelasticity is the property of materials that exhibit both viscous and elastic characteristics when undergoing deformation. Synthetic polymers, wood, and human tissue, as well as metals at high temperature, display significant viscoelastic effects. In some applications, even a small viscoelastic response can be significant.

Elastic behavior versus viscoelastic behavior

The difference between elastic materials and viscoelastic materials is that viscoelastic materials have a viscosity factor and the elastic ones don't. Because viscoelastic materials have the viscosity factor, they have a strain rate dependent on time. Purely elastic materials do not dissipate energy (heat) when a load is applied, then removed; however, a viscoelastic substance does.

The following brief introductions are excerpts from Wikipedia:

“Elasticity (physics):

The physical property when materials or objects return to original shape after deformation.

In physics and materials science, elasticity is the ability of a body to resist a distorting influence and to return to its original size and shape when that influence or force is removed. Solid objects will deform when adequate loads are applied to them; if the material is elastic, the object will return to its initial shape and size after removal. This is in contrast to plasticity, in which the object fails to do so and instead remains in its deformed state.

The physical reasons for elastic behavior can be quite different for different materials. In metals, the atomic lattice changes size and shape when forces are applied (energy is added to the system). When forces are removed, the lattice goes back to the original lower energy state. For rubbers and other polymers, elasticity is caused by the

stretching of polymer chains when forces are applied.

Hooke's law states that the force required to deform elastic objects should be directly proportional to the distance of deformation, regardless of how large that distance becomes. This is known as perfect elasticity, in which a given object will return to its original shape no matter how strongly it is deformed. This is an ideal concept only; most materials which possess elasticity in practice remain purely elastic only up to very small deformations, after which plastic (permanent) deformation occurs.

In engineering, the elasticity of a material is quantified by the elastic modulus such as the Young's modulus, bulk modulus or shear modulus which measure the amount of stress needed to achieve a unit of strain; a higher modulus indicates that the material is harder to deform. The material's elastic limit or yield strength is the maximum stress that can arise before the onset of plastic deformation.

Plasticity (physics):

Deformation of a solid material undergoing non-reversible changes of shape in response to applied forces.

In physics and materials science, plasticity, also known as plastic deformation, is the ability of a solid material to undergo permanent deformation, a non-reversible change of shape in response to applied forces. For example, a solid piece of metal being bent or pounded into a new shape displays plasticity as permanent changes occur within the material itself. In engineering, the transition from elastic behavior to plastic behavior is known as yielding.

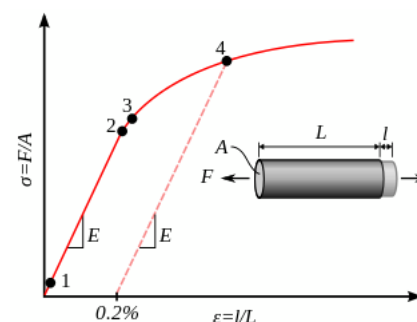

Stress–strain curve showing typical yield behavior for nonferrous alloys.

1. True elastic limit
2. Proportionality limit
3. Elastic limit
4. Offset yield strength

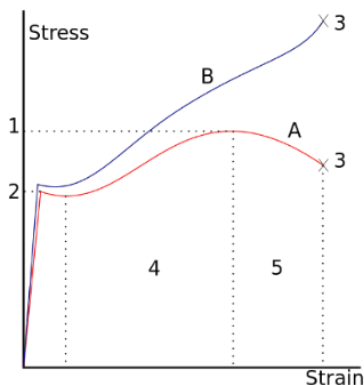

A stress–strain curve typical of structural steel.

- 1: Ultimate strength
- 2: Yield strength (yield point)
- 3: Rupture
- 4: Strain hardening region
- 5: Necking region
- A: Apparent stress (F/A_0)
- B: Actual stress (F/A)

Plastic deformation is observed in most materials, particularly metals, soils, rocks, concrete, and foams. However, the physical mechanisms that cause plastic deformation can vary widely. At a crystalline scale, plasticity in metals is usually a consequence of dislocations. Such defects are relatively rare in most crystalline materials, but are numerous in some and part of their crystal structure; in such cases, plastic crystallinity can result. In brittle materials such as rock, concrete and bone, plasticity is caused predominantly by slip at microcracks. In cellular materials such as liquid foams or biological tissues, plasticity is mainly a consequence of bubble or cell rearrangements, notably T1 processes.

For many ductile metals, tensile loading applied to a sample will cause it to behave in an elastic manner. Each increment of load is accompanied by a proportional increment in extension. When the load is removed, the piece returns to its original size. However, once the load exceeds a threshold – the yield strength – the extension increases more rapidly than in the elastic region; now when

the load is removed, some degree of extension will remain.

Elastic deformation, however, is an approximation and its quality depends on the time frame considered and loading speed. If, as indicated in the graph opposite, the deformation includes elastic deformation, it is also often referred to as "elasto-plastic deformation" or "elastic-plastic deformation".

Perfect plasticity is a property of materials to undergo irreversible deformation without any increase in stresses or loads. Plastic materials that have been hardened by prior deformation, such as cold forming, may need increasingly higher stresses to deform further. Generally, plastic deformation is also dependent on the deformation speed, i.e. higher stresses usually have to be applied to increase the rate of deformation. Such materials are said to deform viscoplastically.”

Viscoelasticity:

Property of materials with both viscous and elastic characteristics under deformation.

In materials science and continuum mechanics, viscoelasticity is the property of materials that exhibit both viscous and elastic characteristics when undergoing deformation. Viscous materials, like water, resist shear flow and strain linearly with time when a stress is applied. Elastic materials strain when stretched and immediately return to their original state once the stress is removed.

Viscoelastic materials have elements of both of these properties and, as such, exhibit time-dependent strain. Whereas elasticity is usually the result of bond stretching along crystallographic planes in an ordered solid, viscosity is the result of the diffusion of atoms or molecules inside an amorphous material.

In the nineteenth century, physicists such as Maxwell, Boltzmann, and Kelvin researched and experimented with creep and recovery of glasses, metals, and rubbers. Viscoelasticity was further examined in the late twentieth century when synthetic polymers were engineered and used in a variety of applications. Viscoelasticity calculations depend heavily on the viscosity variable, η . The inverse of η is also known as fluidity, ϕ . The value of either can be derived as a

function of temperature or as a given value (i.e., for a dashpot).

Depending on the change of strain rate versus stress inside a material, the viscosity can be categorized as having a linear, non-linear, or plastic response. When a material exhibits a linear response, it is categorized as a Newtonian material. In this case the stress is linearly proportional to the strain rate. If the material exhibits a non-linear response to the strain rate, it is categorized as non-Newtonian fluid. There is also an interesting case where the viscosity decreases as the shear/strain rate remains constant. A material which exhibits this type of behavior is known as thixotropic. In addition, when the stress is independent of this strain rate, the material exhibits plastic deformation. Many viscoelastic materials exhibit rubber like behavior explained by the thermodynamic theory of polymer elasticity.

Cracking occurs when the strain is applied quickly and outside of the elastic limit. Ligaments and tendons are viscoelastic, so the extent of the potential damage to them depends both on the rate of the change of their length as well as on the force applied.

A viscoelastic material has the following properties:

- hysteresis is seen in the stress–strain curve
- stress relaxation occurs: step constant strain causes decreasing stress
- creep occurs: step constant stress causes increasing strain
- its stiffness depends on the strain rate or the stress rate.

Elastic versus viscoelastic behavior

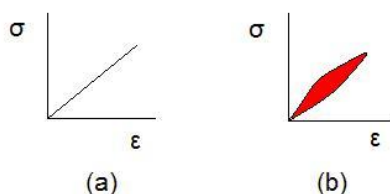

Stress–strain curves for a purely elastic material (a) and a viscoelastic material (b). The red area is a hysteresis loop and shows the amount of energy lost (as heat) in a loading and unloading cycle. It is equal to

$$\oint \sigma d\epsilon$$

where σ is stress and ϵ is strain.

Unlike purely elastic substances, a viscoelastic substance has an elastic component and a viscous component. The viscosity of a viscoelastic substance gives the substance a strain rate dependence on time. Purely elastic materials do not dissipate energy (heat) when a load is applied, then removed. However, a viscoelastic substance dissipates energy when a load is applied, then removed. Hysteresis is observed in the stress–strain curve, with the area of the loop being equal to the energy lost during the loading cycle. Since viscosity is the resistance to thermally activated plastic deformation, a viscous material will lose energy through a loading cycle. Plastic deformation results in lost energy, which is uncharacteristic of a purely elastic material's reaction to a loading cycle.

Specifically, viscoelasticity is a molecular rearrangement. When a stress is applied to a viscoelastic material such as a polymer, parts of the long polymer chain change positions. This movement or rearrangement is called “creep”. Polymers remain a solid material even when these parts of their chains are rearranging in order to accompany the stress, and as this occurs, it creates a back stress in the material. When the back stress is the same magnitude as the applied stress, the material no longer creeps. When the original stress is taken away, the accumulated back stresses will cause the polymer to return to its original form. The material creeps, which gives the prefix visco-, and the material fully recovers, which gives the suffix -elasticity.

Viscoplasticity:

Viscoplasticity is a theory in continuum mechanics that describes the rate-dependent inelastic behavior of solids. Rate-dependence in this context means that the deformation of the material depends on the rate at which loads are applied. The inelastic behavior that is the subject of viscoplasticity is plastic deformation which means that the material undergoes unrecoverable deformations when a load level is reached. Rate-dependent plasticity is important for transient plasticity calculations. The main difference between rate-independent plastic and viscoplastic material models is that the latter exhibit not

only permanent deformations after the application of loads but continue to undergo a creep flow as a function of time under the influence of the applied load.

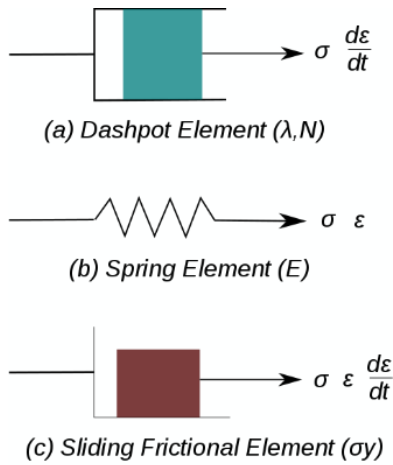

Figure 1. Elements used in one-dimensional models of viscoplastic materials.

The elastic response of viscoplastic materials can be represented in one-dimension by Hookean spring elements. Rate-dependence can be represented by nonlinear dashpot elements in a manner similar to viscoelasticity. Plasticity can be accounted for by adding sliding frictional elements as shown in Figure 1. In the figure E is the modulus of elasticity, λ is the viscosity parameter and N is a power-law type parameter that represents non-linear dashpot [$\sigma(d\epsilon/dt) = \sigma = \lambda(d\epsilon/dt)^{1/N}$]. The sliding element can have a yield stress (σ_y) that is strain rate dependent, or even constant, as shown in Figure 1c.

Viscoplasticity is usually modeled in three-dimensions using overstress models of the Perzyna or Duvaut-Lions types. In these models, the stress is allowed to increase beyond the rate-independent yield surface upon application of a load and then allowed to relax back to the yield surface over time. The yield surface is usually assumed not to be rate-dependent in such models. An alternative approach is to add a strain rate dependence to the yield stress and use the techniques of rate independent plasticity to calculate the response of a material.

For metals and alloys, viscoplasticity is the macroscopic behavior caused by a mechanism linked to the movement of dislocations in grains, with superposed effects of inter-

crystalline gliding. The mechanism usually becomes dominant at temperatures greater than approximately one third of the absolute melting temperature. However, certain alloys exhibit viscoplasticity at room temperature (300K). For polymers, wood, and bitumen, the theory of viscoplasticity is required to describe behavior beyond the limit of elasticity or viscoelasticity.

In general, viscoplasticity theories are useful in areas such as

- the calculation of permanent deformations,
- the prediction of the plastic collapse of structures,
- the investigation of stability,
- crash simulations,
- systems exposed to high temperatures such as turbines in engines, e.g. a power plant,
- dynamic problems and systems exposed to high strain rates.

Phenomenology

For a qualitative analysis, several characteristic tests are performed to describe the phenomenology of viscoplastic materials. Some examples of these tests are

1. hardening tests at constant stress or strain rate,
2. creep tests at constant force, and
3. stress relaxation at constant elongation.

Strain hardening test

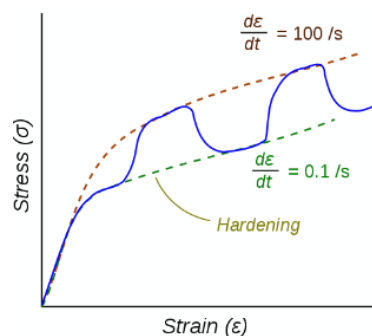

Figure 2. Stress–strain response of a viscoplastic material at different strain rates.

The dotted lines show the response if the strain-rate is held constant. The blue line

shows the response when the strain rate is changed suddenly.

One consequence of yielding is that as plastic deformation proceeds, an increase in stress is required to produce additional strain. This phenomenon is known as Strain/Work hardening. For a viscoplastic material the hardening curves are not significantly different from those of rate-independent plastic material. Nevertheless, three essential differences can be observed.

1. At the same strain, the higher the rate of strain the higher the stress.
2. A change in the rate of strain during the test results in an immediate change in the stress-strain curve.
3. The concept of a plastic yield limit is no longer strictly applicable.

The hypothesis of partitioning the strains by decoupling the elastic and plastic parts is still applicable where the strains are small, i.e.,

$$\epsilon = \epsilon_e + \epsilon_{vp}$$

where ϵ_e is the elastic strain and ϵ_{vp} is the viscoplastic strain.

To obtain the stress-strain behavior shown in blue in the figure, the material is initially loaded at a strain rate of 0.1/s. The strain rate is then instantaneously raised to 100/s and held constant at that value for some time. At the end of that time period the strain rate is dropped instantaneously back to 0.1/s and the cycle is continued for increasing values of strain. There is clearly a lag between the strain-rate change and the stress response. This lag is modeled quite accurately by overstress models (such as the Perzyna model) but not by models of rate-independent plasticity that have a rate-dependent yield stress.”

Note: For a more detailed description, please refer to the “consolidated method” section which is given at the beginning of the special issue.

3. RESULTS

Figure 1 shows the VGT analysis results for pancreatic, liver, and overall cancer risks based on their respective influential factors.

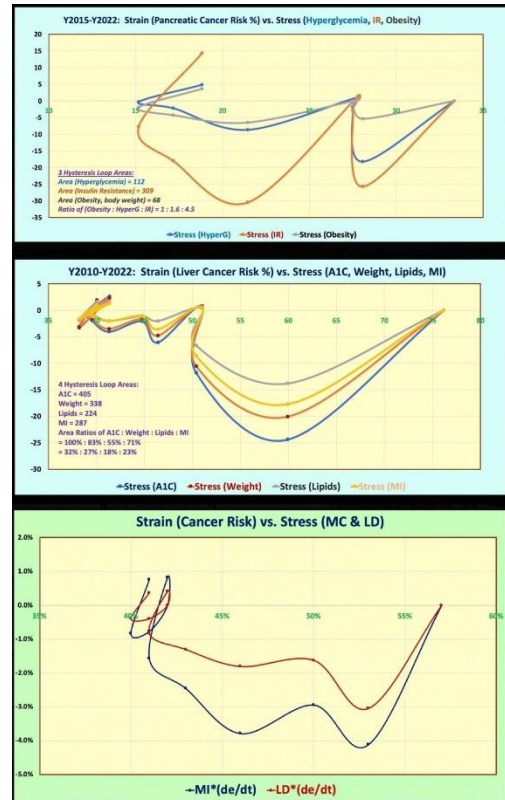

Figure 1: Risks of pancreatic cancer, liver cancer, and overall cancers based on medical conditions and lifestyle details.

Figure 2 illustrates the VGT analysis result of overall cancer risk based on A1C, body weight, diet, and exercise with its supporting data table during a 12+ years period from 1/1/2010 to 4/15/2022.

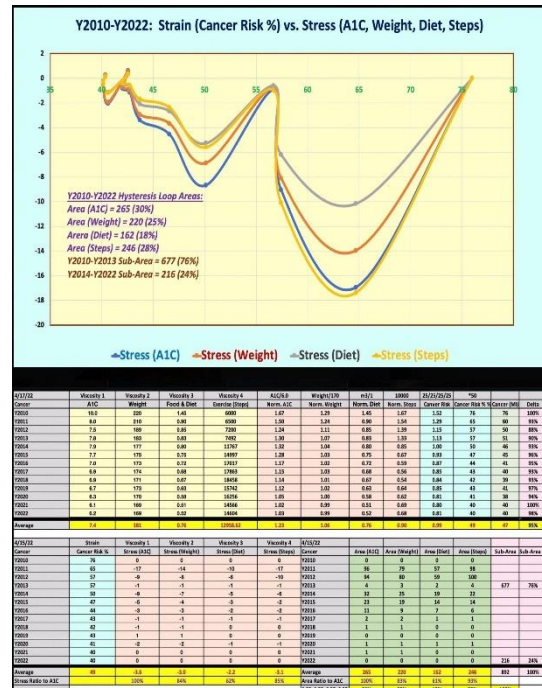

Figure 2: Overall cancer risk based on A1C, weight, diet, and exercise with supporting data table (Y2010-Y2022).

4. CONCLUSION

In summary, the author's research work generally match with the 2010 consensus report findings issued by the ACS and ADA jointly. Despite vast different symptoms between diabetes and cancers, both diseases do share some common root-causes.

The following four described biophysical characteristics have demonstrated certain key behaviors of his pancreatic, liver, and overall cancer risks under various influential factors, which he refers them as "root causes", using the viscoplastic energy (VGT) approach:

(1) From the x-axis value or the strain value on the stress-strain diagram, we can observe the risk range covered by each cancer type: pancreatic cancer risk (33% in 2015 to 19% in 2022); liver cancer risk (76 in 2010 to 40% in 2022); overall cancer risk (76% in 2010 to 40% in 2022). It should be mentioned again that all of these cancer risks are relative numbers, not absolute numbers. The important observation is that all of the cancer risks are decreasing.

(2) From the y-axis (stress) values and the hysteresis loop areas, we can see that both the stress values and the hysteresis loop areas for the period of Y2010-Y2013 are larger than the period of Y2014-Y2022. This indicates that he is "healthier" during the recent 8 years; therefore, his cancer risks have been reduced accordingly due to the improvements in those influential factors. It should also be pointed out that his pancreatic cancer (PC) risks are covered by a shorter period from Y 2015 to Y2022 only and its most prominent and less-satisfied influential factor is his insulin resistance. This is due to the self-repairing pancreatic beta cells being an extremely slow and difficult process which is different from improvements on his glucoses, weights, and lifestyle details.

(3) Based on the comparison of loop area size, or degrees of influence, the summarized sub-

area of 76% for earlier years of Y2010-Y2013 is three times bigger than the summarized sub-area of 24% for recent years of Y2014-Y2022. His stringent lifestyle management program initiated in Y2014 has indeed changed the perspectives of his cancer risk and therefore reduced his overall cancer risks.

(4) When he delved deeper into the comparisons among the influential factors, he can further identify some additional details regarding his "efforts and results" for each influential factor. Examples of his detailed observations are: MI is better than medical conditions, lifestyle details (LD) is better than medical conditions (MC), blood lipid is better than glucoses, weight control is better than hyperglycemic control, and hyperglycemia control is better than insulin resistance (IR) improvement.

This summarized cancer risk article has demonstrated how the author utilizes the physics and engineering, VGT energy methodology, to construct and display his research result findings of cancer risk % resulting from multiple influential factors.

5. REFERENCES

For editing purposes, the majority of the references in this paper, which are self-references, have been removed. Only references from other authors' published sources remain. The bibliography of the author's original self-references can be viewed at www.eclaircmd.com.

Readers may use this article as long as the work is properly cited, their use is educational and not for profit, and the author's original work is not altered

- 1) Giovannucci E, Harlan DM, Archer MC, et al. Diabetes and cancer: a consensus report. *Diabetes Care*. 2010;33(7):1674-85.

Viscoelastic and Viscoplastic Glucose Theory Application in Medicine

Gerald C. Hsu

