

The GH-Method

Viscoelastic and Viscoplastic Glucose Theory (VGT #7): Applying Elasticity, Plasticity, Viscoelasticity, and Energy Theories for the Residual Effect on Postprandial Plasma Glucose by Comparing Two Different Time Periods Resulting from Single Hyperglycemic Lunch Based on GH-Method: Math-Physical Medicine (No. 586)

Gerald C. Hsu*

eclairMD Foundation, USA

Note: Readers who want to get a quick overview can read the abstract, results, and graphs.

Abstract

The author celebrated his birthday with a lunch party on 1/16/2022, where he consumed 20% of a large cake. His finger-pierced postprandial plasma glucose (PPG) level reached 171 mg/dL after the luncheon. Afterwards, over several days, he noticed that his overall PPG level and estimated daily average glucose level (eAG) also increased. Out of curiosity regarding the possible extent of the residual effect on his PPG and eAG due to a single hyperglycemic glucose, he decided to conduct this particular research work. The following paragraphs outline his work steps of the project. First, he queried his database containing 4,134 meals from the period of 5/5/2018 to 1/26/2022 for lunches with hyperglycemic levels above 170 mg/dL. He identified 20 hyperglycemic lunches. Next, he selected the following from the 20 days data: carbs/sugar intake amount, post-meal walking k-steps, finger PPG, and eAG. He then created an independent data table used to calculate the corresponding average values. Second, he chose the 10 prior days, excluding the luncheon and labeled them the “prior” period, and the 10 post days, which included the birthday lunch, named the “post” period. He then synthesized the ~30 meals’ PPG data of each period and transferred them into another data table. By using the time-domain PPG dataset with 15-minute intervals for a 3-hour timeframe for each meal’s PPG, he plotted the time-domain PPG waveforms for the prior and post periods. Third, he selected the synthesized PPG values as the strain (ϵ) and the PPG change rate as the strain rate ($d\epsilon/dt$), multiplied with his average carbs/sugar grams i.e., viscosity factor (η), as his stress (σ), in order to construct two separate stress-strain diagrams. The following defined equations are used to establish his stress-strain diagram: strain = ϵ = individual PPG value at present time. Stress

= $\sigma = \eta * (d\epsilon/dt) = \eta * (d\text{-strain}/d\text{-time}) = (\text{viscosity factor } \eta \text{ using averaged carbs/sugar intake amount for a selected period}) * (\text{PPG at present time} - \text{PPG at previous time}) / 15$, where 15 indicates the 15-minutes timespan of his collected PPG data. Fourth, he used the fast Fourier transform (FFT) operation to convert his two synthesized PPG waveform from a time-domain into a frequency-domain. He then calculated the associated energy of PPG in both time-domain and frequency-domain using the following two equations: Energy in time-domain (TD) = Summation of squares for each sample (each glucose component on the Y-axis of TD). Energy in frequency-domain (FD) = Summation of squares for each sample (each Y-axis value of FD corresponding to each frequency component on the X-axis of FD) is divided by the total number of samples (total number-counts on the X-axis of FD). After completing the above-described steps, he obtained or generated the following useful information: (1) An organized raw data table containing hyperglycemic PPG, eAG, carbs/sugar grams (viscosity factor, η), and post-meal walking k-steps. (2) A detailed PPG data and waveform for each prior period and post period and two synthesized periods (prior and post) of time-domain PPG data and waveform. (3) Two constructed stress-strain diagrams for the prior and post periods, respectively. (4) A set of calculated TD energies and FD energies associated with the prior period PPG wave and post period PPG wave. To offer a simple explanation to readers who do not have a physics or engineering background, the author includes a brief excerpt from Wikipedia regarding the description of basic concepts for elasticity and plasticity theories, viscoelasticity and viscoplasticity theories from the disciplines of engineering and physics in the

Method section. In summary, the following five statements outline his findings from this research work: (1) From time-domain waveforms, there are small PPG differences of 2-3 mg/dL between 0-minute and 180-minutes, i.e. permanent deformation. From a grand view, his PPG data are still in the elastic stage, however, it has initiated to enter into the plastic stage. This explains why linear elastic glucose theory (LEGT) results have achieved 99% of the prediction accuracy on average PPG. The linear elasticity theory is still the most useful model. (2) From the stress-strain diagram, there are two separate small opening holes or creep between 0-minute and 180-minutes. In addition, the almost identical PPG strain values at 45-minutes and 60-minutes indicate the existence of plastic or viscoelastic phenomenon and their associated creep phenomenon as well. These hysteresis loops and creeps reflect that both periods demonstrate the viscoelastic characters. (3) From the stress-strain diagram, the stress calculation involves the strain rate or PPG change rate, and viscosity factor or carbs/sugar amount. There are some insignificant but still noticeable differences on between prior PPG stress and post PPG stress. First, the post period's PPG change rate after 75-minutes has a noticeable difference from the corresponding portion of the prior period. Second, the prior period's viscosity factor is 14.3 grams, while the post period's viscosity factor is 16.9 grams with a 15% difference. These two reasons caused the pattern difference between these two periods in the stress-strain diagram. The post period's stress-strain diagram is slightly larger in size (11% larger from two hysteresis loop area ratio of post = 81.2 versus prior = 73.1) and shifts toward the right side (slightly higher PPG by 2-3 mg/dL). This slightly bigger area of the hysteresis loop is a result from the 15% higher

viscosity factor (higher carbs/sugar amount). Incidentally, in the stress-strain diagram, the curves in the lower portion between 75-minutes and 180-minutes appear different between the two periods. This is a result from the different strain rate (PPG change rate) after 75-minutes. The different area sizes of the two hysteresis loops indicate different amounts of energy loss in the loading process via carbs/sugar intake and the unloading process via post-meal exercise. (4) The above-mentioned energy can be reconfirmed via the estimated energy calculation using the TD and FD models through a FFT operation. The PPG associated energy comparison between the post to prior is 106% for TD and 102% for FD. Although the energy differences are not significant, the differences do match all other findings from this study. These 2%-6% of energy difference also reflects the area difference of two hysteresis loops. (5) Despite the rough estimates from the period count, 14 post periods (70%) of finger PPG, 13 post periods (65%) of continuous glucose monitoring (CGM) sensor PPG, and 13 post periods (65%) of eAG, from a total of 20 periods, having a higher PPG value than the corresponding prior periods. However, the predominant fact is that the post period has higher average glucose than the prior period has been proven. All of above illustrations have indicated a conclusion that consuming a single hyperglycemic meal would definitely generate higher PPG and its associated energy for the 10-day post period compared to the 10-day prior period. This residual impact on diabetic conditions is evident and the post-hyperglycemic impact can be illustrated and interpreted quite well using the established theories of elasticity, plasticity, viscoelasticity, viscoplasticity, energy and viscoelasticity creep phenomenon.

Keywords: Viscoelastic; Viscoplastic; Postprandial plasma glucose; Diabetes; Glucose

Abbreviations: FPG: fasting plasma glucose; PPG: postprandial plasma glucose; TD: time-domain; FD: frequency-domain; CGM: continuous glucose monitoring

1. INTRODUCTION

The author celebrated his birthday with a lunch party on 1/16/2022, where he consumed 20% of a large cake. His finger-pierced postprandial plasma glucose (PPG) level reached 171 mg/dL after the luncheon. Afterwards, over several days, he noticed that his overall PPG level and estimated daily average glucose level (eAG) also increased. Out of curiosity regarding the possible extent of the residual effect on his PPG and eAG due to a single hyperglycemic glucose, he decided to conduct this particular research work. The following paragraphs outline his work steps of the project.

First, he queried his database containing 4,134 meals from the period of 5/5/2018 to 1/26/2022 for lunches with hyperglycemic levels above 170 mg/dL. He identified 20 hyperglycemic lunches. Next, he selected the following from the 20 days data: carbs/sugar intake amount, post-meal walking k-steps, finger PPG, and eAG. He then created an independent data table used to calculate the corresponding average values.

Second, he chose the 10 prior days, excluding the luncheon and labeled them the “prior” period, and the 10 post days, which included the birthday lunch, named the “post” period. He then synthesized the ~30 meals’ PPG data of each period and transferred them into another data table. By using the time-domain PPG dataset with 15-minute intervals for a 3-hour timeframe for each meal’s PPG, he plotted the time-domain PPG waveforms for the prior and post periods.

Third, he selected the synthesized PPG values as the strain (ϵ) and the PPG change rate as the strain rate ($d\epsilon/dt$), multiplied with his average carbs/sugar grams i.e., viscosity factor (η), as his stress (σ), in order to construct two separate stress-strain diagrams. The following defined equations are used to establish his stress-strain diagram:

Strain

= ϵ

= individual PPG value at present time

Stress

= σ

= $\eta * (d\epsilon/dt)$

= $\eta * (d\text{-strain}/d\text{-time})$

= (viscosity factor η using averaged carbs/sugar intake amount for a selected period) * (PPG at present time - PPG at previous time) / 15

Where 15 indicates the 15-minutes timespan of his collected PPG data.

Fourth, he used the fast Fourier transform (FFT) operation to convert his two synthesized PPG waveform from a time-domain into a frequency-domain. He then calculated the associated energy of PPG in both time-domain and frequency-domain using the following two equations:

Energy in time-domain (TD)

= Summation of squares for each sample (each glucose component on the Y-axis of TD)

Energy in frequency-domain (FD)

= Summation of squares for each sample (each Y-axis value of FD corresponding to each frequency component on the X-axis of FD) is divided by the total number of samples (total number-counts on the X-axis of FD).

After completing the above-described steps, he obtained or generated the following useful information:

(1) An organized raw data table containing hyperglycemic PPG, eAG, carbs/sugar grams (viscosity factor, η), and post-meal walking k-steps (~4.0 k-steps).

(2) A detailed PPG data and waveform for each prior period and post period and two synthesized periods (prior and post) of time-domain PPG data and waveform.

(3) Two constructed stress-strain diagrams for the prior and post periods, respectively.

(4) A set of calculated TD energies and FD energies associated with the prior period PPG wave and post period PPG wave.

To offer a simple explanation to readers who do not have a physics or engineering background, the author includes a brief excerpt from Wikipedia regarding the description of basic concepts for elasticity and plasticity theories, viscoelasticity and viscoplasticity theories from the disciplines of

engineering and physics in the Method section.

2. METHODS

2.1 Elasticity, plasticity, viscoelasticity, and viscoplasticity

The difference between elastic materials and viscoelastic materials (from “Soborthans, innovating shock and vibration solutions”).

What are elastic materials?

Elasticity is the tendency of solid materials to return to their original shape after forces are applied on them. When the forces are removed, the object will return to its initial shape and size if the material is elastic.

What are viscous materials?

Viscosity is a measure of a fluid’s resistance to flow. A fluid with large viscosity resists motion. A fluid with low viscosity flows. For example, water flows more easily than syrup because it has a lower viscosity. High viscosity materials might include honey, syrups, or gels – generally things that resist flow. Water is a low viscosity material, as it flows readily. Viscous materials are thick or sticky or adhesive. Since heating reduces viscosity, these materials don't flow easily. For example, warm syrup flows more easily than cold.

What is viscoelastic?

Viscoelasticity is the property of materials that exhibit both viscous and elastic characteristics when undergoing deformation. Synthetic polymers, wood, and human tissue, as well as metals at high temperature, display significant viscoelastic effects. In some applications, even a small viscoelastic response can be significant.

Elastic behavior versus viscoelastic behavior

The difference between elastic materials and viscoelastic materials is that viscoelastic materials have a viscosity factor and the elastic ones don't. Because viscoelastic materials have the viscosity factor, they have a strain rate dependent on time. Purely elastic materials do not dissipate energy (heat) when a load is applied, then removed; however, a viscoelastic substance does.

The following brief introductions are excerpts from Wikipedia:

“Elasticity (physics):

Physical property when materials or objects return to original shape after deformation.

In physics and materials science, elasticity is the ability of a body to resist a distorting influence and to return to its original size and shape when that influence or force is removed. Solid objects will deform when adequate loads are applied to them; if the material is elastic, the object will return to its initial shape and size after removal. This is in contrast to plasticity, in which the object fails to do so and instead remains in its deformed state.

The physical reasons for elastic behavior can be quite different for different materials. In metals, the atomic lattice changes size and shape when forces are applied (energy is added to the system). When forces are removed, the lattice goes back to the original lower energy state. For rubbers and other polymers, elasticity is caused by the stretching of polymer chains when forces are applied.

Hooke's law states that the force required to deform elastic objects should be directly proportional to the distance of deformation, regardless of how large that distance becomes. This is known as perfect elasticity, in which a given object will return to its original shape no matter how strongly it is deformed. This is an ideal concept only; most materials which possess elasticity in practice remain purely elastic only up to very small deformations, after which plastic (permanent) deformation occurs.

In engineering, the elasticity of a material is quantified by the elastic modulus such as the Young's modulus, bulk modulus or shear modulus which measure the amount of stress needed to achieve a unit of strain; a higher modulus indicates that the material is harder to deform. The material's elastic limit or yield strength is the maximum stress that can arise before the onset of plastic deformation.

Plasticity (physics):

Deformation of a solid material undergoing non-reversible changes of shape in response to applied forces.

In physics and materials science, plasticity, also known as plastic deformation, is the ability of a solid material to undergo permanent deformation, a non-reversible change of shape in response to applied forces. For example, a solid piece of metal being bent or pounded into a new shape displays plasticity as permanent changes occur within the material itself. In engineering, the transition from elastic behavior to plastic behavior is known as yielding.

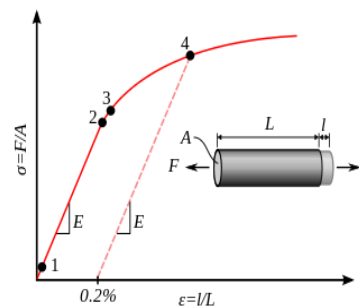

A stress-strain curve showing typical yield behavior for nonferrous alloys.

1. True elastic limit
2. Proportionality limit
3. Elastic limit
4. Offset yield strength

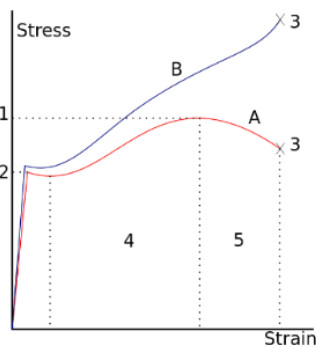

A stress-strain curve typical of structural steel.

- 1: Ultimate strength
- 2: Yield strength (yield point)
- 3: Rupture
- 4: Strain hardening region
- 5: Necking region
- A: Apparent stress (F/A₀)
- B: Actual stress (F/A)

Plastic deformation is observed in most materials, particularly metals, soils, rocks, concrete, and foams. However, the physical mechanisms that cause plastic deformation can vary widely. At a crystalline scale, plasticity in metals is usually a consequence of dislocations. Such defects are relatively rare in most crystalline materials, but are numerous in some and part of their crystal structure; in such cases, plastic crystallinity can result. In brittle materials such as rock, concrete and bone, plasticity is caused predominantly by slip at microcracks. In cellular materials such as liquid foams or biological tissues, plasticity is mainly a consequence of bubble or cell rearrangements, notably T1 processes.

For many ductile metals, tensile loading applied to a sample will cause it to behave in an elastic manner. Each increment of load is accompanied by a proportional increment in extension. When the load is removed, the piece returns to its original size. However, once the load exceeds a threshold – the yield strength – the extension increases more rapidly than in the elastic region; now when the load is removed, some degree of extension will remain.

Elastic deformation, however, is an approximation and its quality depends on the time frame considered and loading speed. If, as indicated in the graph opposite, the deformation includes elastic deformation, it is also often referred to as "elasto-plastic deformation" or "elastic-plastic deformation".

Perfect plasticity is a property of materials to undergo irreversible deformation without any increase in stresses or loads. Plastic materials that have been hardened by prior deformation, such as cold forming, may need increasingly higher stresses to deform further. Generally, plastic deformation is also dependent on the deformation speed, i.e. higher stresses usually have to be applied to increase the rate of deformation. Such materials are said to deform viscoplastically.”

Viscoelasticity:

Property of materials with both viscous and elastic characteristics under deformation.

In materials science and continuum mechanics, viscoelasticity is the property of

materials that exhibit both viscous and elastic characteristics when undergoing deformation. Viscous materials, like water, resist shear flow and strain linearly with time when a stress is applied. Elastic materials strain when stretched and immediately return to their original state once the stress is removed.

Viscoelastic materials have elements of both of these properties and, as such, exhibit time-dependent strain. Whereas elasticity is usually the result of bond stretching along crystallographic planes in an ordered solid, viscosity is the result of the diffusion of atoms or molecules inside an amorphous material.

In the nineteenth century, physicists such as Maxwell, Boltzmann, and Kelvin researched and experimented with creep and recovery of glasses, metals, and rubbers. Viscoelasticity was further examined in the late twentieth century when synthetic polymers were engineered and used in a variety of applications. Viscoelasticity calculations depend heavily on the viscosity variable, η . The inverse of η is also known as fluidity, ϕ . The value of either can be derived as a function of temperature or as a given value (i.e. for a dashpot).

Depending on the change of strain rate versus stress inside a material, the viscosity can be categorized as having a linear, non-linear, or plastic response. When a material exhibits a linear response it is categorized as a Newtonian material. In this case the stress is linearly proportional to the strain rate. If the material exhibits a non-linear response to the strain rate, it is categorized as Non-Newtonian fluid. There is also an interesting case where the viscosity decreases as the shear/strain rate remains constant. A material which exhibits this type of behavior is known as thixotropic. In addition, when the stress is independent of this strain rate, the material exhibits plastic deformation. Many viscoelastic materials exhibit rubber like behavior explained by the thermodynamic theory of polymer elasticity.

Cracking occurs when the strain is applied quickly and outside of the elastic limit. Ligaments and tendons are viscoelastic, so the extent of the potential damage to them depends both on the rate of the change of their length as well as on the force applied.

A viscoelastic material has the following properties:

- hysteresis is seen in the stress-strain curve
- stress relaxation occurs: step constant strain causes decreasing stress
- creep occurs: step constant stress causes increasing strain
- its stiffness depends on the strain rate or the stress rate.

Elastic versus viscoelastic behavior:

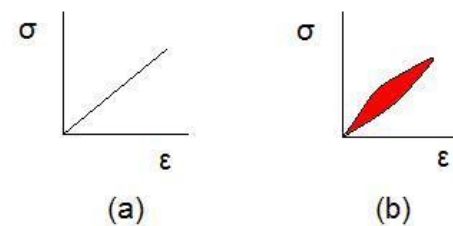

Stress-strain curves for a purely elastic material (a) and a viscoelastic material (b). The red area is a hysteresis loop and shows the amount of energy lost (as heat) in a loading and unloading cycle. It is equal to $\oint \sigma d\epsilon$ where σ is stress and ϵ is strain.

Unlike purely elastic substances, a viscoelastic substance has an elastic component and a viscous component. The viscosity of a viscoelastic substance gives the substance a strain rate dependence on time. Purely elastic materials do not dissipate energy (heat) when a load is applied, then removed. However, a viscoelastic substance dissipates energy when a load is applied, then removed. Hysteresis is observed in the stress-strain curve, with the area of the loop being equal to the energy lost during the loading cycle. Since viscosity is the resistance to thermally activated plastic deformation, a viscous material will lose energy through a loading cycle. Plastic deformation results in lost energy, which is uncharacteristic of a purely elastic material's reaction to a loading cycle.

Specifically, viscoelasticity is a molecular rearrangement. When a stress is applied to a viscoelastic material such as a polymer, parts of the long polymer chain change positions. This movement or rearrangement is called "creep". Polymers remain a solid material even when these parts of their chains are

rearranging in order to accompany the stress, and as this occurs, it creates a back stress in the material. When the back stress is the same magnitude as the applied stress, the material no longer creeps. When the original stress is taken away, the accumulated back stresses will cause the polymer to return to its original form. The material creeps, which gives the prefix visco-, and the material fully recovers, which gives the suffix -elasticity.

Viscoplasticity:

Viscoplasticity is a theory in continuum mechanics that describes the rate-dependent inelastic behavior of solids. Rate-dependence in this context means that the deformation of the material depends on the rate at which loads are applied. The inelastic behavior that is the subject of viscoplasticity is plastic deformation which means that the material undergoes unrecoverable deformations when a load level is reached. Rate-dependent plasticity is important for transient plasticity calculations. The main difference between rate-independent plastic and viscoplastic material models is that the latter exhibit not only permanent deformations after the application of loads but continue to undergo a creep flow as a function of time under the influence of the applied load.

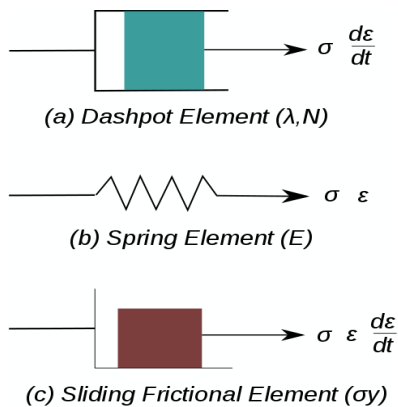

Figure 1. Elements used in one-dimensional models of viscoplastic materials.

The elastic response of viscoplastic materials can be represented in one-dimension by Hookean spring elements. Rate-dependence can be represented by nonlinear dashpot elements in a manner similar to viscoelasticity. Plasticity can be accounted for by adding sliding frictional elements as shown in Figure 1. In the figure E is the modulus of elasticity, λ is the viscosity

parameter and N is a power-law type parameter that represents non-linear dashpot [$\sigma(d\epsilon/dt) = \lambda(d\epsilon/dt)^{1/N}$]. The sliding element can have a yield stress (σ_y) that is strain rate dependent, or even constant, as shown in Figure 1c.

Viscoplasticity is usually modeled in three-dimensions using overstress models of the Perzyna or Duvaut-Lions types. In these models, the stress is allowed to increase beyond the rate-independent yield surface upon application of a load and then allowed to relax back to the yield surface over time. The yield surface is usually assumed not to be rate-dependent in such models. An alternative approach is to add a strain rate dependence to the yield stress and use the techniques of rate independent plasticity to calculate the response of a material.

For metals and alloys, viscoplasticity is the macroscopic behavior caused by a mechanism linked to the movement of dislocations in grains, with superposed effects of inter-crystalline gliding. The mechanism usually becomes dominant at temperatures greater than approximately one third of the absolute melting temperature. However, certain alloys exhibit viscoplasticity at room temperature (300K). For polymers, wood, and bitumen, the theory of viscoplasticity is required to describe behavior beyond the limit of elasticity or viscoelasticity.

In general, viscoplasticity theories are useful in areas such as

- the calculation of permanent deformations,
- the prediction of the plastic collapse of structures,
- the investigation of stability,
- crash simulations,
- systems exposed to high temperatures such as turbines in engines, e.g. a power plant,
- dynamic problems and systems exposed to high strain rates.

Phenomenology

For a qualitative analysis, several characteristic tests are performed to describe the phenomenology of viscoplastic materials. Some examples of these tests are

1. hardening tests at constant stress or strain rate,
2. creep tests at constant force, and
3. stress relaxation at constant elongation.

Strain hardening test

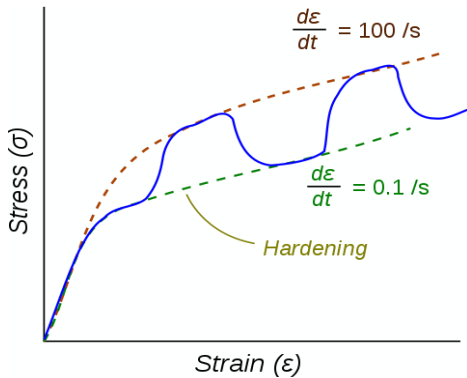

Figure 2. Stress–strain response of a viscoplastic material at different strain rates.

The dotted lines show the response if the strain-rate is held constant. The blue line shows the response when the strain rate is changed suddenly.

One consequence of yielding is that as plastic deformation proceeds, an increase in stress is required to produce additional strain. This phenomenon is known as Strain/Work hardening. For a viscoplastic material the hardening curves are not significantly different from those of rate-independent plastic material. Nevertheless, three essential differences can be observed.

1. At the same strain, the higher the rate of strain the higher the stress
2. A change in the rate of strain during the test results in an immediate change in the stress–strain curve.
3. The concept of a plastic yield limit is no longer strictly applicable.

The hypothesis of partitioning the strains by decoupling the elastic and plastic parts is still applicable where the strains are small, i.e.,

$$\epsilon = \epsilon_e + \epsilon_{vp}$$

where ϵ_e is the elastic strain and ϵ_{vp} is the viscoplastic strain.

To obtain the stress–strain behavior shown in blue in the figure, the material is initially

loaded at a strain rate of 0.1/s. The strain rate is then instantaneously raised to 100/s and held constant at that value for some time. At the end of that time period the strain rate is dropped instantaneously back to 0.1/s and the cycle is continued for increasing values of strain. There is clearly a lag between the strain-rate change and the stress response. This lag is modeled quite accurately by overstress models (such as the Perzyna model) but not by models of rate-independent plasticity that have a rate-dependent yield stress.

Note: For a more detailed description, please refer to the “consolidated method” section which is given at the beginning of the special issue.

3. RESULTS

Figure 1 displays the data table of both input data and calculation results.

1/26/22	Finger	Prior -10 days	Post +10 days						
Date	Lunch PPG	PPG	Carbs	K-steps	eAG	PPG	Carbs	K-steps	eAG
5/23/18	178	115.3	15.6	9,922	112.8	121.8	15.5	4,444	122.8
7/3/18	197	115.8	11.4	4,840	136.6	118.3	20.1	4,923	129.9
7/23/18	180	119.7	17.3	4,768	121.8	121.6	18.7	5,005	125.4
8/16/18	197	111.0	13.8	5,208	134.5	119.0	14.6	4,730	131.7
10/26/18	194	120.3	18.6	4,195	123.3	120.0	22.9	4,663	139.4
11/22/18	200	112.5	17.8	4,034	123.8	119.2	20.6	4,096	134.0
2/8/19	200	113.8	13.8	5,181	126.4	119.7	19.9	3,767	128.7
4/16/19	175	116.0	12.7	2,973	133.0	121.0	17.6	2,649	127.8
4/25/19	215	119.3	14.8	2,527	128.0	116.1	14.5	3,755	125.8
6/12/19	200	123.5	16.7	2,792	145.8	121.1	13.6	3,907	153.8
11/9/19	213	110.2	10.5	4,691	130.9	119.7	22.4	3,560	141.3
11/16/19	178	115.6	16.9	4,098	143.8	116.6	24.4	4,335	136.6
1/11/20	183	111.9	17.3	5,231	126.1	117.4	14.8	4,099	136.1
3/8/20	198	112.1	7.9	3,975	116.3	116.5	8.2	4,259	121.9
5/6/20	228	110.3	11.8	4,504	119.6	105.5	12.0	4,010	115.7
1/13/21	170	103.1	20.5	4,701	106.4	118.3	18.6	4,848	127.5
3/17/21	173	103.4	14.9	4,589	119.3	104.9	13.3	4,776	119.6
7/13/21	187	108.9	10.7	3,627	108.8	107.9	13.5	3,760	104.5
12/21/21	170	107.2	10.1	4,181	104.2	105.6	15.4	3,317	105.2
1/16/22	171	113.8	12.6	4,519	109.2	123.6	17.1	3,817	119.4
Average	190.3	113.2	14.3	4,238	123	116.7	16.9	4,108	127
LEGT PPG (Glu + Modules)						2.0			
LEGT of Carbs & K-steps				28.6	-21.2			33.8	-20.5
Assumed PPG	105.8								
LEGT Predicted PPG	113.2					119.0			
eAG Diff. (Post-Prior)									3.9
LEGT PPG Diff. (Post-Prior)									5.8
Finger PPG Diff. (Post-Prior)									3.6
PPG Diff. (LEGT-Finger)	0.0								2.3
									Creep

Prior -10 days	Case 1	Case 2	Case 3	Case 4	Case 5	Case 6	Case 7	Case 8	Case 9	Case 10	Case 11	Case 12	Case 13	Case 14	Case 15	Case 16	Case 17	Case 18	Case 19	Case 20
PPG	110	108	108	107	107	106	106	105	105	104	104	103	103	102	102	101	101	100	100	99
Carbs	15	15	15	15	15	15	15	15	15	15	15	15	15	15	15	15	15	15	15	15
K-steps	100	100	100	100	100	100	100	100	100	100	100	100	100	100	100	100	100	100	100	100
eAG	115	115	115	115	115	115	115	115	115	115	115	115	115	115	115	115	115	115	115	115
PPG Diff.	0.0	0.0	0.0	0.0	0.0	0.0	0.0	0.0	0.0	0.0	0.0	0.0	0.0	0.0	0.0	0.0	0.0	0.0	0.0	0.0
Carbs Diff.	0.0	0.0	0.0	0.0	0.0	0.0	0.0	0.0	0.0	0.0	0.0	0.0	0.0	0.0	0.0	0.0	0.0	0.0	0.0	0.0
K-steps Diff.	0.0	0.0	0.0	0.0	0.0	0.0	0.0	0.0	0.0	0.0	0.0	0.0	0.0	0.0	0.0	0.0	0.0	0.0	0.0	0.0
eAG Diff.	0.0	0.0	0.0	0.0	0.0	0.0	0.0	0.0	0.0	0.0	0.0	0.0	0.0	0.0	0.0	0.0	0.0	0.0	0.0	0.0

Prior +10 days	Case 1	Case 2	Case 3	Case 4	Case 5	Case 6	Case 7	Case 8	Case 9	Case 10	Case 11	Case 12	Case 13	Case 14	Case 15	Case 16	Case 17	Case 18	Case 19	Case 20
PPG	124	124	124	124	124	124	124	124	124	124	124	124	124	124	124	124	124	124	124	124
Carbs	15	15	15	15	15	15	15	15	15	15	15	15	15	15	15	15	15	15	15	15
K-steps	100	100	100	100	100	100	100	100	100	100	100	100	100	100	100	100	100	100	100	100
eAG	127	127	127	127	127	127	127	127	127	127	127	127	127	127	127	127	127	127	127	127
PPG Diff.	0.0	0.0	0.0	0.0	0.0	0.0	0.0	0.0	0.0	0.0	0.0	0.0	0.0	0.0	0.0	0.0	0.0	0.0	0.0	0.0
Carbs Diff.	0.0	0.0	0.0	0.0	0.0	0.0	0.0	0.0	0.0	0.0	0.0	0.0	0.0	0.0	0.0	0.0	0.0	0.0	0.0	0.0
K-steps Diff.	0.0	0.0	0.0	0.0	0.0	0.0	0.0	0.0	0.0	0.0	0.0	0.0	0.0	0.0	0.0	0.0	0.0	0.0	0.0	0.0
eAG Diff.	0.0	0.0	0.0	0.0	0.0	0.0	0.0	0.0	0.0	0.0	0.0	0.0	0.0	0.0	0.0	0.0	0.0	0.0	0.0	0.0

Synthesized PPG	Prior PPG	Post PPG	Prior LEGT	Post LEGT
15 min	127	131	127	131
30 min	133	136	131	135
45 min	137	141	134	138
60 min	137	141	137	141
75 min	136	139	136	140
90 min	132	137	135	138
105 min	129	133	133	137
120 min	127	132	132	136
135 min	126	131	131	134
150 min	125	131	129	133
165 min	127	130	128	131
180 min	127	130	127	130
Average PPG	129.7	133.9	131.1	134.7
Glu + modules	0.94	0.79		
Glu + modules	-2.54	-2.81		
PPG Diff. Post - CGM PPG	4.1		Viscoelastic	
PPG Diff. Post - Finger PPG	3.6		Data Accuracy Issue	
PPG Diff. Post - LEGT PPG	3.6		Linear Elastic	

Viscoelastic	Prior Strain	Prior Stress	Post Strain	Post Stress
15 min	3	3	3	4
30 min	6	6	6	6
45 min	4	4	5	5
60 min	0	0	0	0
75 min	-3	-3	-3	-2
90 min	-2	-2	-2	-2
105 min	-2	-2	-2	-2
120 min	-2	-2	-2	-2
135 min	-1	-1	-1	-1
150 min	0	0	0	0
165 min	0	0	0	0
180 min	0	0	0	0
Average PPG	0.2	0.2	0.2	0.2
Viscosity	16.3			
TD Energy	16.831			17.231
FD Energy	250.00			255.33
TD Energy %	100%			
FD Energy %	100%			

Figure 1: Data table of both input data and calculation results.

Figure 2 shows the time-domain PPG waveforms from the 20 cases synthesized PPG and LEGT erved PPG.

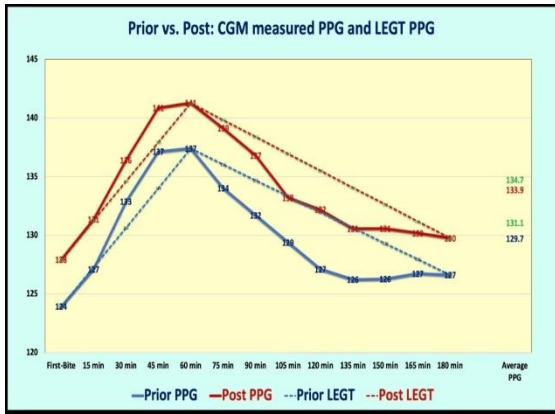

Figure 2: Time-domain PPG and LEGT PPG of prior period and post period.

Figure 3 shows the results of the stress-strain diagrams from viscoelastic study for both prior period and post period.

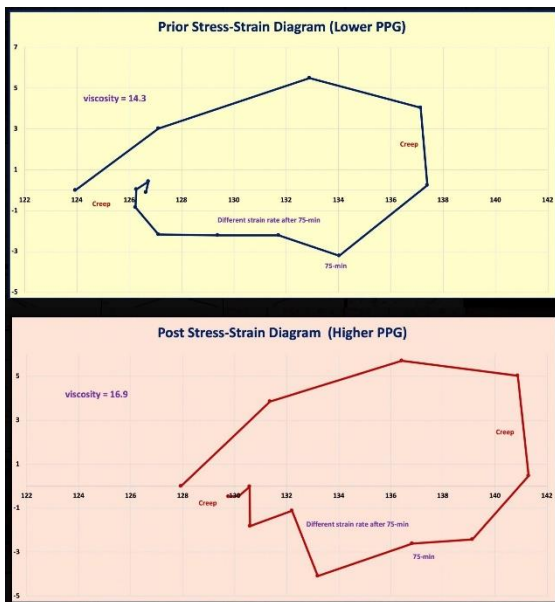

Figure 3: Viscoelastic stress-strain diagram (upper diagram is prior period and lower diagram is post period).

Figure 4 demonstrated the PPG associated energy estimation from both time-domain and frequency-domain.

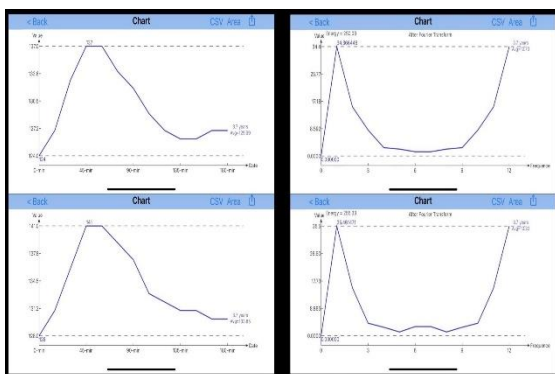

Figure 4: Comparison of PPG associated energy of both prior period and post period (left diagram is time-domain and right diagram is frequency domain).

Figure 5 shows the stress calculation table with different strain rates and viscosity factors for both prior period and post period.

(de/dt) & eta	Prior		Post		Post-Prior	
eta=14.3&16.9	e-rate	e-rat* eta	e-rate	e-rat* eta	e-rate	e-rat* eta
0 min	0%	0.0	0%	0.0	0%	0.0
15 min	21%	3.0	23%	3.9	2%	0.8
30 min	39%	5.5	34%	5.7	-5%	0.2
45 min	28%	4.1	30%	5.0	1%	1.0
60 min	2%	0.2	3%	0.5	1%	0.2
75 min	-23%	-3.2	-14%	-2.4	8%	0.8
90 min	-15%	-2.2	-15%	-2.6	0%	-0.4
105 min	-15%	-2.2	-24%	-4.1	-9%	-1.9
120 min	-15%	-2.2	-7%	-1.1	9%	1.0
135 min	-6%	-0.8	-11%	-1.8	-5%	-1.0
150 min	0%	0.0	0%	0.0	0%	-0.1
165 min	3%	0.4	-3%	-0.4	-6%	-0.9
180 min	-1%	-0.1	-3%	-0.5	-2%	-0.4
Average	1.4%	0.20	0.9%	0.16	-0.4%	-0.04

Figure 5: Stress calculation table with different strain rates and viscosity factors.

Figure 6 demonstrates the sample calculation of a randomly created looped area using the trapezoid area formula of :

$$\text{Trapezoid area} = ((a+b)/2)*h$$

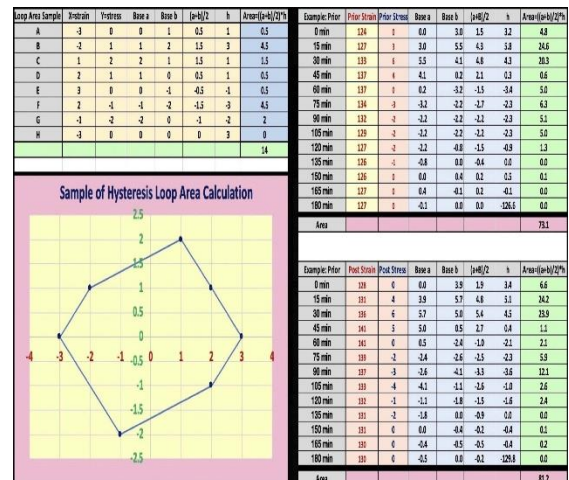

Figure 6: Hysteresis loop area sizes for both prior case and post case.

It also shows calculations for those two hysteresis loop areas of both prior case and post case.

4. CONCLUSION

In summary, the following five statements outline his findings from this research work:

- (1) From time-domain waveforms, there are small PPG differences of 2-3 mg/dL between 0-minute and 180-minutes, i.e. permanent deformation. From a grand view, his PPG data are still in the elastic stage, however, it

has initiated to enter into the plastic stage. This explains why linear elastic glucose theory (LEGT) results have achieved 99% of the prediction accuracy on average PPG. The linear elasticity theory is still the most useful model.

(2) From the stress-strain diagram, there are two separate small opening holes or creep between 0-minute and 180-minutes. In addition, the almost identical PPG strain values at 45-minutes and 60-minutes indicate the existence of plastic or viscoelastic phenomenon and their associated creep phenomenon as well. These hysteresis loops and creeps reflect that both periods demonstrate the viscoelastic characters.

(3) From the stress-strain diagram, the stress calculation involves the strain rate or PPG change rate, and viscosity factor or carbs/sugar amount. There are some insignificant but still noticeable differences on between prior PPG stress and post PPG stress. First, the post period's PPG change rate after 75-minutes has a noticeable difference from the corresponding portion of the prior period. Second, the prior period's viscosity factor is 14.3 grams, while the post period's viscosity factor is 16.9 grams with a 15% difference. These two reasons caused the pattern difference between these two periods in the stress-strain diagram. The post period's stress-strain diagram is slightly larger in size (11% larger from two hysteresis loop area ratio of post = 81.2 versus prior = 73.1) and shifts toward the right side (slightly higher PPG by 2-3 mg/dL). This slightly bigger area of the hysteresis loop is a result from the 15% higher viscosity factor (higher carbs/sugar amount). Incidentally, in the stress-strain diagram, the curves in the lower portion between 75-minutes and 180-minutes appear different between the two periods. This is a result from the different strain rate (PPG change rate) after 75-minutes. The different area sizes of the two hysteresis loops indicate different amounts of energy loss in the loading process via carbs/sugar intake and the unloading process via post-meal exercise.

(4) The above-mentioned energy can be reconfirmed via the estimated energy calculation using the TD and FD models through a FFT operation. The PPG associated energy comparison between the post to prior is 106% for TD and 102% for FD.

Although the energy differences are not significant, the differences do match all other findings from this study. These 2%-6% of energy difference also reflects the area difference of two hysteresis loops.

(5) Despite the rough estimates from the period count, 14 post periods (70%) of finger PPG, 13 post periods (65%) of continuous glucose monitoring (CGM) sensor PPG, and 13 post periods (65%) of eAG, from a total of 20 periods, having a higher PPG value than the corresponding prior periods. However, the predominant fact is that the post period has higher average glucose than the prior period has been proven.

All of above illustrations have indicated a conclusion that consuming a single hyperglycemic meal would definitely generate higher PPG and its associated energy for the 10-day post period compared to the 10-day prior period. This residual impact on diabetic conditions is evident and the post-hyperglycemic impact can be illustrated and interpreted quite well using the established theories of elasticity, plasticity, viscoelasticity, viscoplasticity, energy and viscoelasticity creep phenomenon.

5. ACKNOWLEDGMENT

Without Professor Norman Jones at MIT as his academic advisor, the author would not be able to conduct his medical research project and also published 500+ research papers. The author has never forgotten his advice to him that he should always enhance his strength on foundations, such as mathematics and physics, in order to make further improvement and advancement. Professor Jones has also provided him a personal example of doing outstanding teaching and research job with an excellent work attitude, extreme dedication, and ultimate commitment on advancing both science and engineering.

6. REFERENCES

For editing purposes, majority of the references in this paper, which are self-references, have been removed for this article. Only references from other authors' published sources remain. The bibliography of the author's original self-references can be viewed at www.eclaircmd.com.

Readers may use this article as long as the work is properly cited, and their use is

educational and not for profit, and the author's original work is not altered.

Viscoelastic and Viscoplastic Glucose Theory Application in Medicine

Gerald C. Hsu

